



We congratulate you for choosing a HARDI plant protection product. The reliability and efficiency of this product depend on your care. The first step is to carefully **read and pay attention** to this instruction book. It contains essential information for the efficient use and long life of this quality product.

As the instruction book covers all TX models, please pay attention to the paragraphs dealing with precisely your model.



Description

The Hardi TX trailed field sprayers consist of a pump, frame with adjustable wheel track gauge and ground clearance, 1500 or 2400 litre tanks, BK operating unit, 12, 15, 16 or 18 metre SPA spray boom with hydraulic lift function and transmission shaft.

The design of the pump is simple, with easily accessible diaphragms and valves that ensures spray liquid does not come in contact with the vital parts of the pump.

The tank, made of impact-proof and chemical resistant polyethylene, has a purposeful design with no sharp edges for easy cleaning and efficient agitation.

The BK 180 K operating unit consists of: pressure agitator, safety valve, on/off function, pressure filter with pressure gauge, distribution valves with pressure equalization device and HARDI-MATIC.

HARDI-MATIC ensures a constant volume per hectare of the liquid at varying speed in the same gear. The number of revolutions on the P.T.O. must be kept between 300-600 r/min.

The SPA spray boom has hydraulic height adjustment. The boom is connected to the frame by a trapeze suspension which in turn is supported by two heavy duty coil springs. A damper is fitted to reduce either lateral trapeze or vertical boom movement. This ensures extra boom stability and longer boom life especially when driving on uneven ground or at high spraying speeds. The outer sections incorporate a spring loaded breakaway. The unfolding and folding is a push/pull system requiring minimal physical effort from the operator. Furthermore, there is a ladder on the left-hand boom transport bracket easing tank access for the filling of sprays, cleaning, etc.

An identification plate fitted on the frame is to indicate model, year of production and serial number, and country of origin.

Notes:



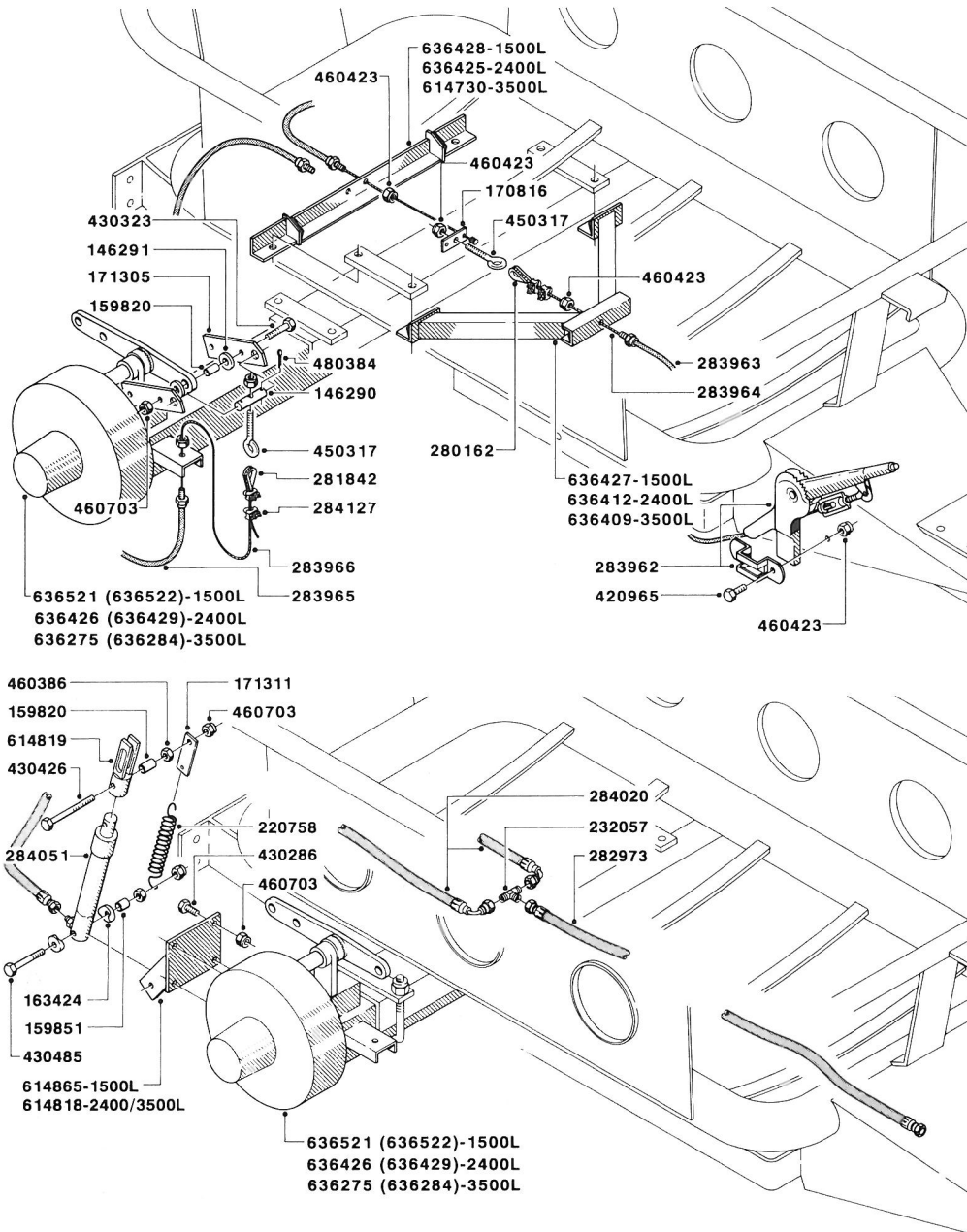

E401 28-8-90

Operation Diagram

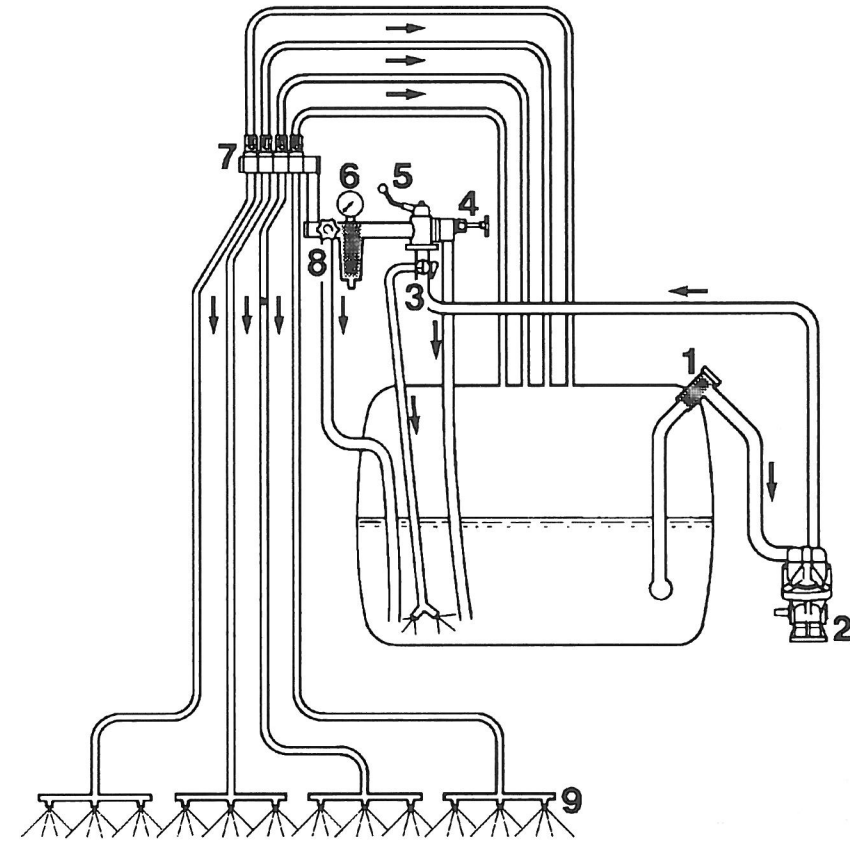

1. Suction filter
2. Pump
3. Pressure agitation
4. Safety valve
5. On/off valve
6. Pressure filter and gauge
7. Distribution valve with pressure equalization
8. HARDI-MATIC
9. Sprayer boom





Connecting the sprayer

Drawbar

The drawbar is equipped with 36 mm swivel towing ring. Two bolts connect the drawbar to the frame. Extra bolt holes and rotation of the drawbar permit different positions to suit tractor hitch.

36mm

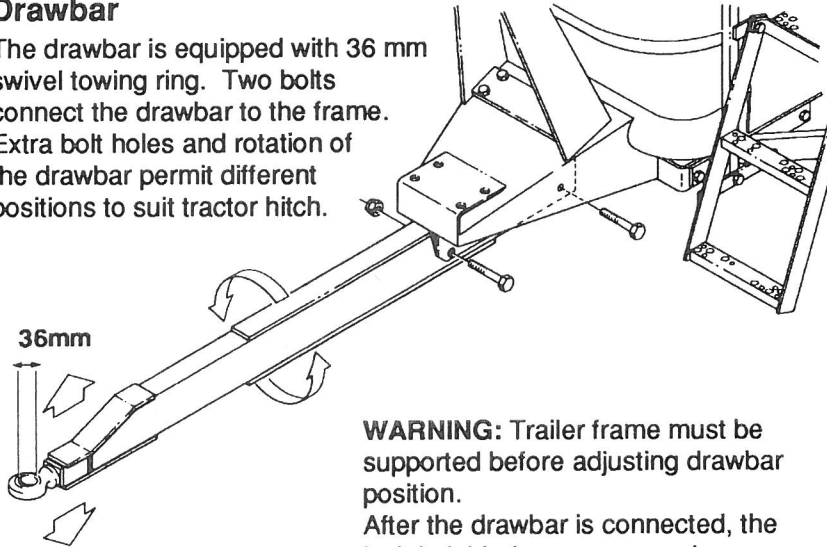

WARNING: Trailer frame must be supported before adjusting drawbar position. After the drawbar is connected, the jack is folded up or removed.



Track gauge and clearance

The track gauge of the trailer can be varied between 1.40 m to 1.80 m depending on model. The two nuts on each U/bolt are loosened, and thereafter the hub axel can be drawn out or pushed in, until the required track gauge is obtained. Ground clearance can be altered by rotating the axles 180°. Remove the little stop lug on the end of the axles if they are rotated.

Drawbar and track gauge are to be set so that the chassis is approximately parallel to the ground.

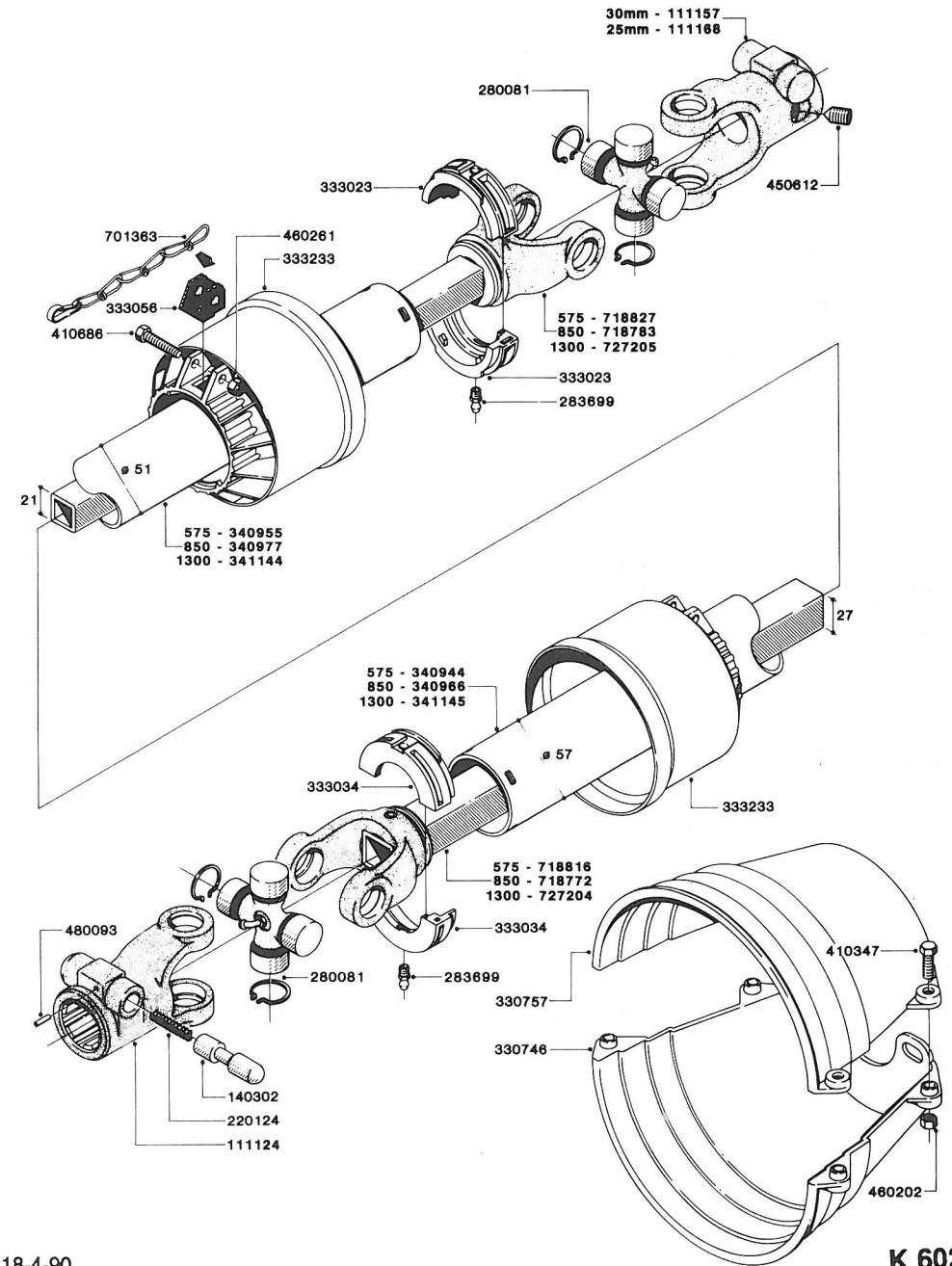
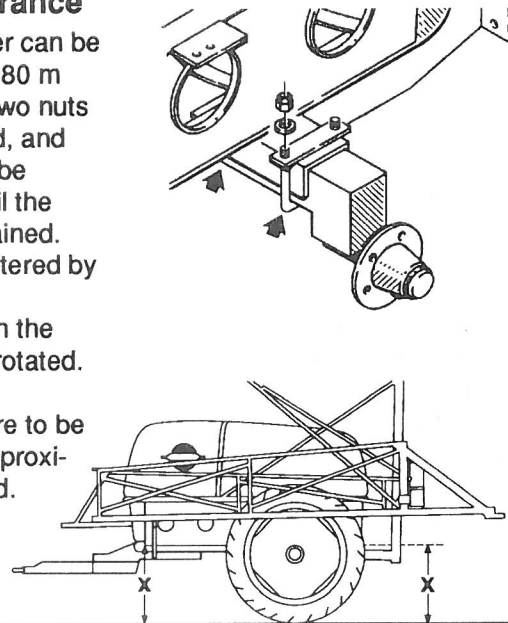

18-4-90

K 602

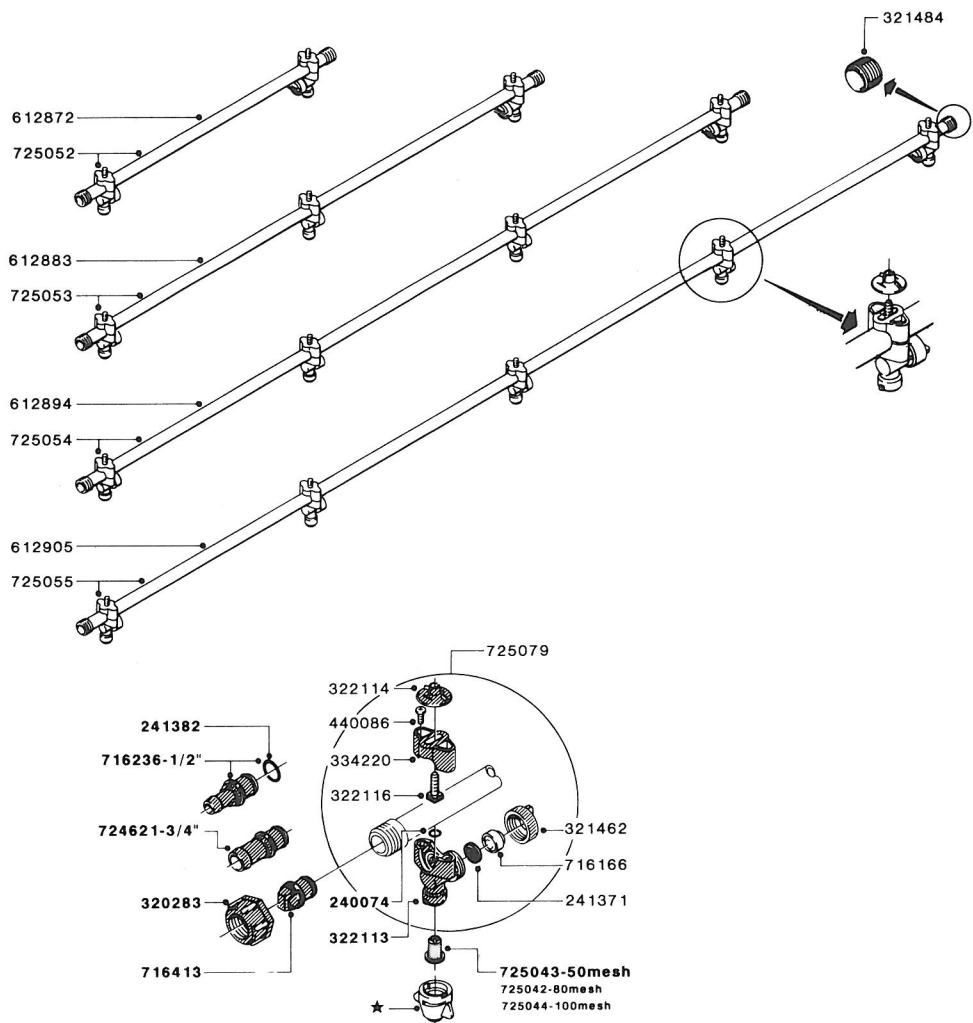

D903 28-8-90

★		FARVE	COLOUR	COULEUR	FARBE	COLOR
371469	S4110-08	VIOLET	VIOLET	VIOLET	VIOLETT	VIOLETA
371470	S4110-10	BRUN	BROWN	BRUN	BRAUN	MARRON
371471	S4110-12	GUL	YELLOW	JAUNE	GELB	AMARILLO
371472	S4110-14	ORANGE	ORANGE	ORANGE	ORANGE	ANARANJADO
371473	S4110-16	RØD	RED	ROUGE	ROT	ROJO
371474	S4110-18	HVID	WHITE	BLANC	WEISS	BLANCO
371475	S4110-20	GRØN	GREEN	VERT	GRÜN	VERDE
371476	S4110-24	TURKIS	TURQUOISE BLUE	BLEU TURQUOISE	TÜRKIS	AZUL TURQUI
371477	S4110-30	BLÅ	BLUE	BLEU	BLAU	AZUL
371478	S4110-36	GRÅ	GREY	GRIS	GRAU	GRIS
371479	S4110-44	ELFENBEN	IVORY	IVOIRE	ELFENBEIN	MARFIL

Parking brake (if fitted)

After the sprayer is connected, release the parking brake by pushing thumb button in and pushing the lever forward. It is recommended to always use the parking brake before disconnecting the sprayer.

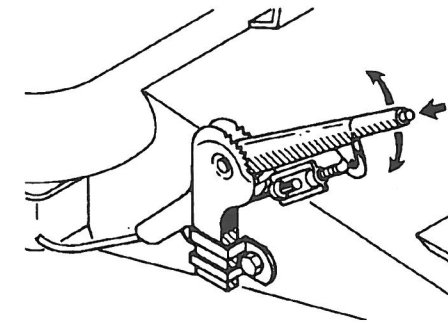

Hydraulics

Hydraulic connection needs one single outlet for the lift function. Note that the hydraulic system requires an oil capacity of approx. 3 litres and a min. pressure of 130 bar.

A ball valve is fitted to the sprayer hydraulic hose. This facilitates connection/disconnection of the hydraulics even if the boom is raised. After connecting to the tractor snap coupler, open valve.

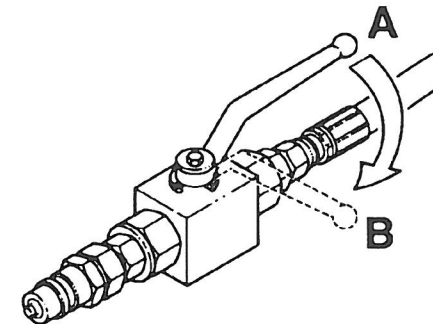

ALWAYS close valve before disconnecting.

A = open
B = close

BE CAUTIOUS WITH INITIAL USE OF THE HYDRAULIC SYSTEM; IF THERE IS AIR IN THE SYSTEM THIS MAY CAUSE VIOLENT MOVEMENTS OF THE BOOM. THEREFORE TAKE CARE THAT NO PERSONS OR OBJECTS ARE HURT OR DAMAGED IN THE PROCESS OF TESTING.





The lift cylinder can be fixed at two different positions on the wagon. Normally, it is fixed at the upper position (C). To gain extra boom height, for example in canola, it can be moved to the lower position (D). A „S“ shaped hook is supplied so the boom can be mechanically blocked when altering position.

To alter position;

1. Unfold boom (see also „Operation of the boom“).
2. Raise boom until „S“ hook can secure wagon/boom from sinking.
3. Remove pin (E) connecting cylinder extension to wagon. Bleeding a small amount of oil from base of lift cylinder will make removal easier.
4. Lift cylinder can now be relocated.

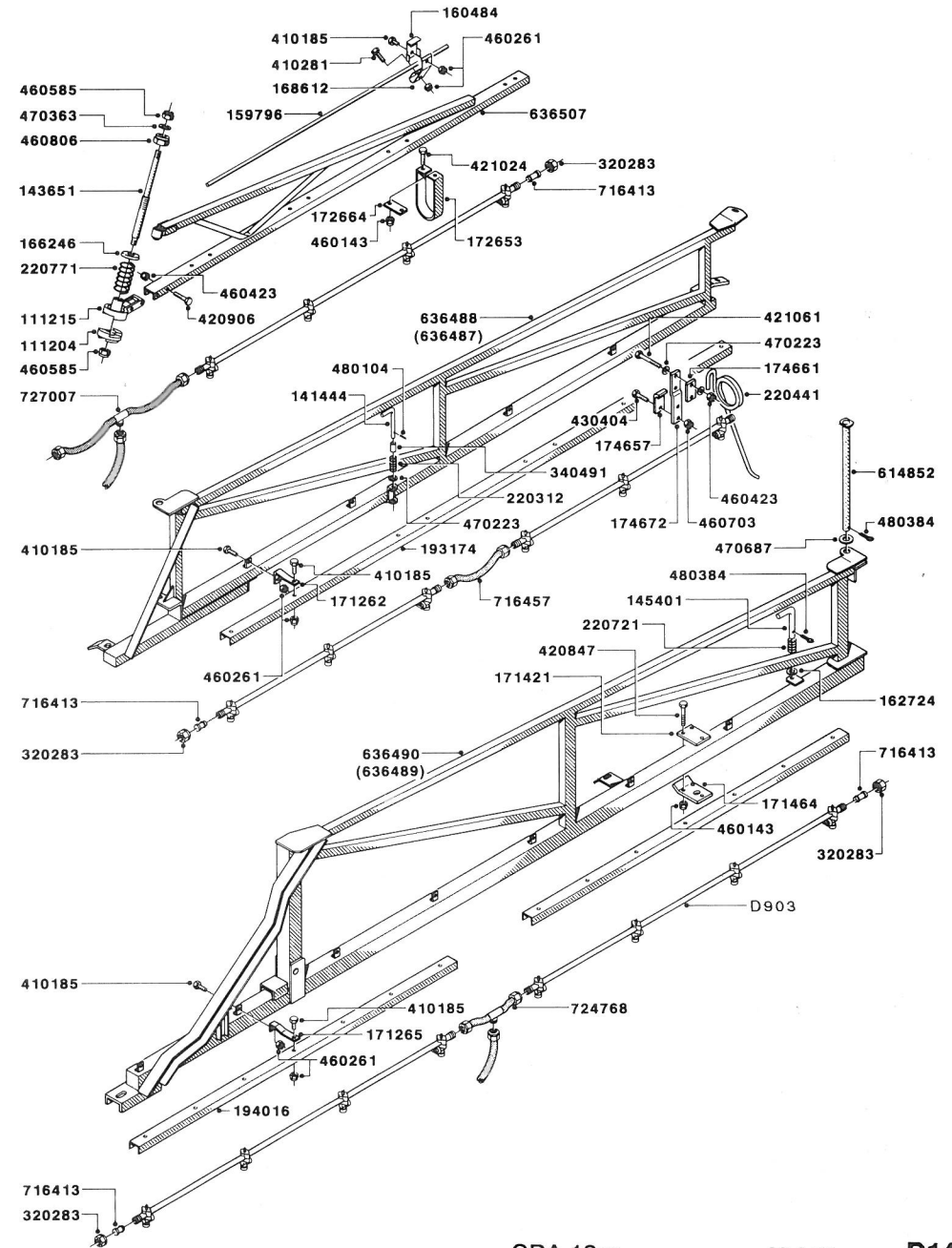
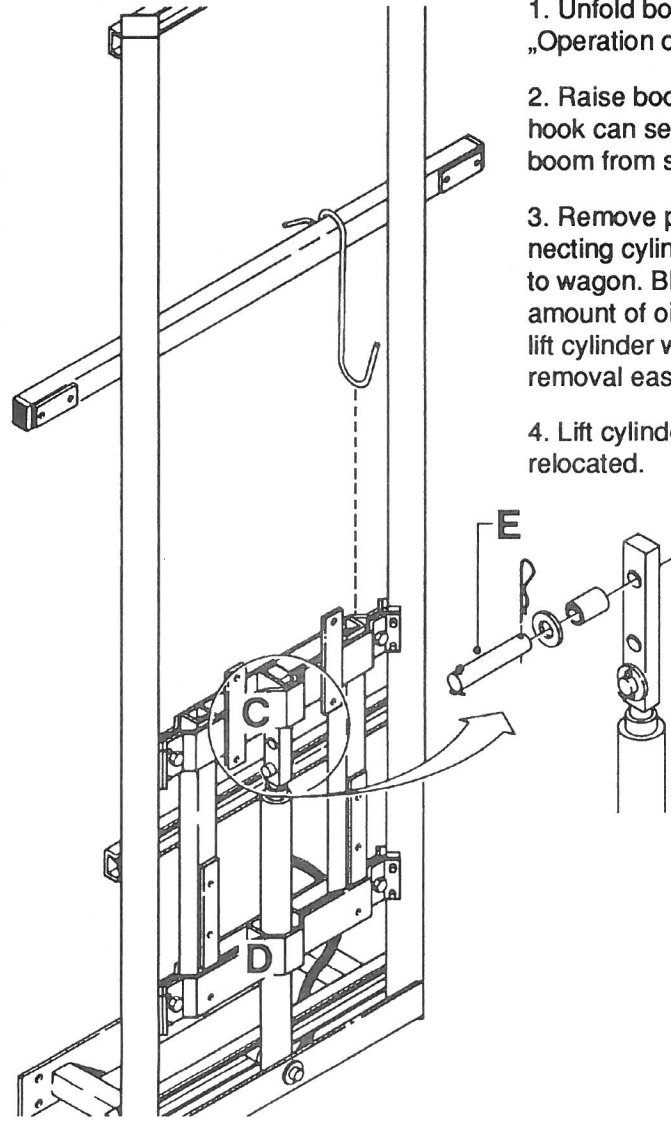

SPA 18m

28-8-90

D14

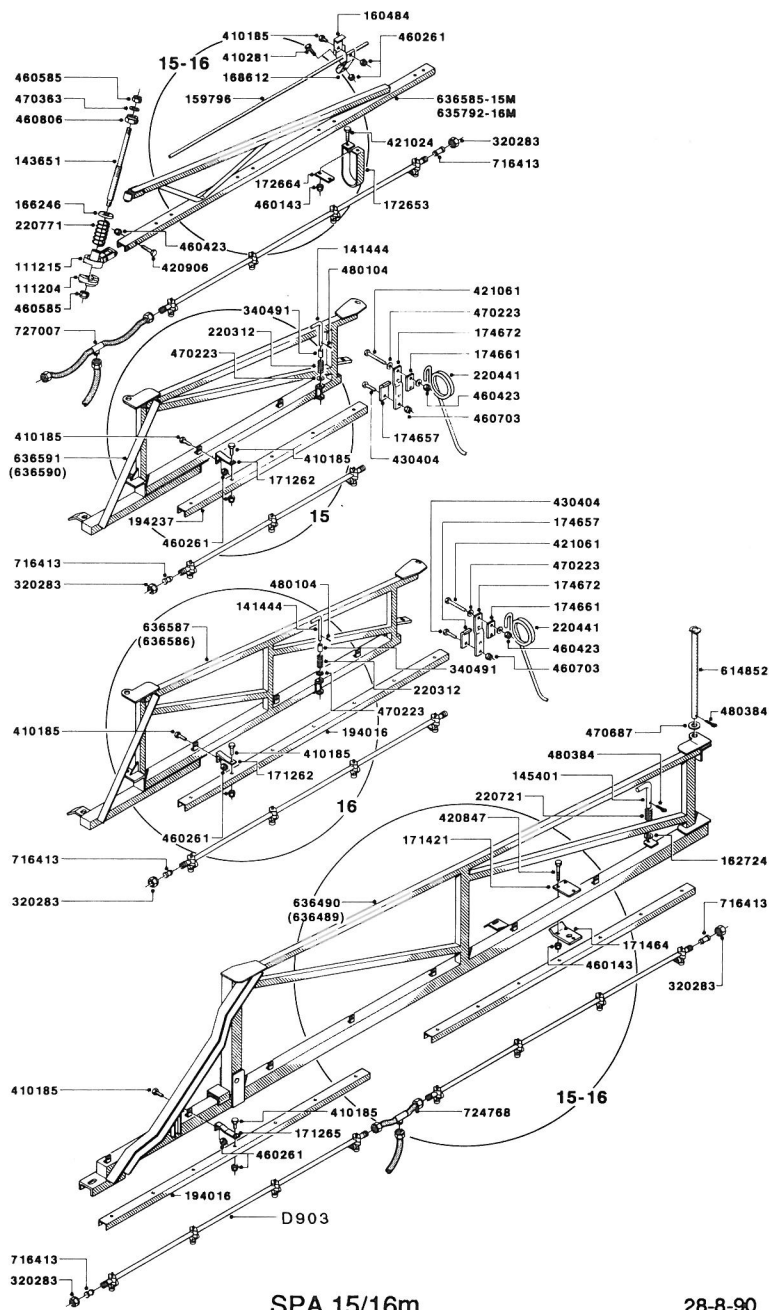

SPA 15/16m

28-8-90

Transmission shaft

When connecting the sprayer to the tractor the length of the transmission shaft should be checked and if necessary shortened. There should be at least 150 mm free play between the male and female parts when the shaft is horizontal. When connected, check by turning sharply. Do this with caution. There should be at least 10 mm between male and female parts when the shaft is at its minimum length.

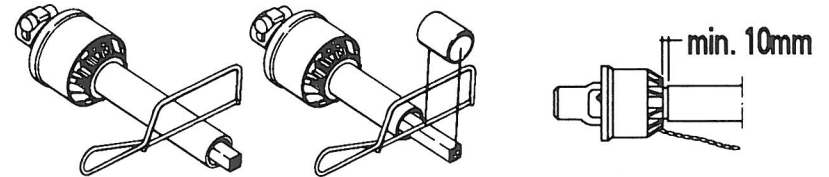

It is important for the personal safety of the operator that the transmission shaft is intact. The protection guards must cover the whole shaft. This includes the universal cross covers at each end of the shaft. The chains are connected so that the protection guards do not rotate with the shaft.

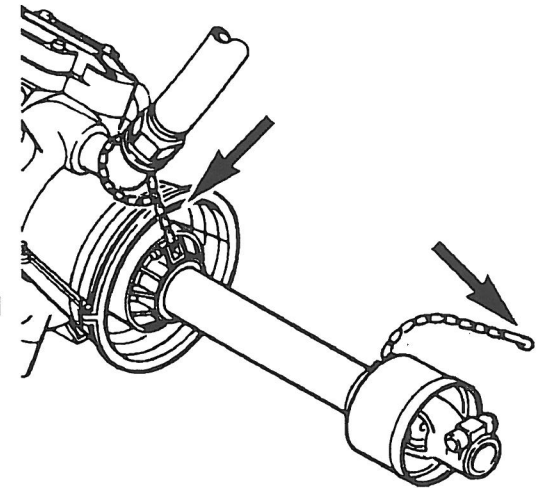

To ensure long life of the transmission shaft, avoid working angles greater than 15° and turning angles greater than 70°.

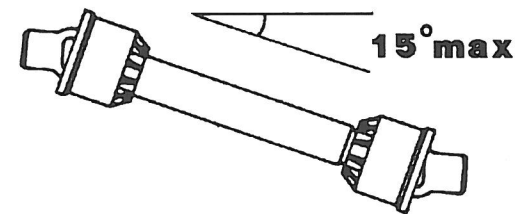



Roadworthiness

When driving on public roads and other areas where the highway code applies, or areas where there are special rules and regulations for marking and lights on implements, you should observe these and equip implements accordingly.

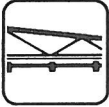

Operating instructions

Operation of the boom

WARNING: WHEN UNFOLDING THE SPRAY BOOM IT IS IMPORTANT THAT THE SPRAYER IS CONNECTED TO THE TRACTOR TO PREVENT OVERBALANCING.

To unfold boom;

1. Remove lynch pins (A) from centre section.

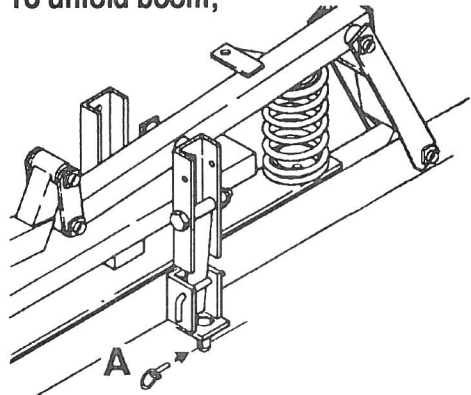

2. Go to transport brackets. Pull spring loaded lock (B) down and pull boom out until the boom can be lifted over the transport bracket. Gently lower.

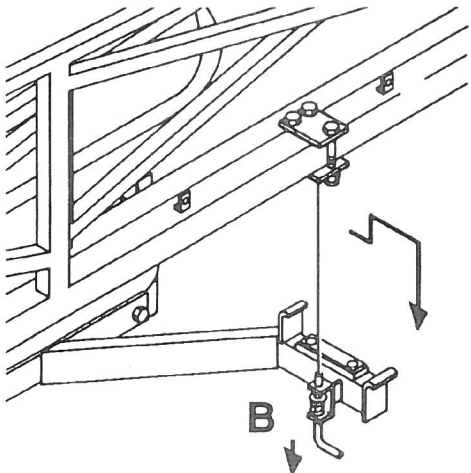

3. The boom will now rest and it can be folded out until it hits the stop on the centre section.

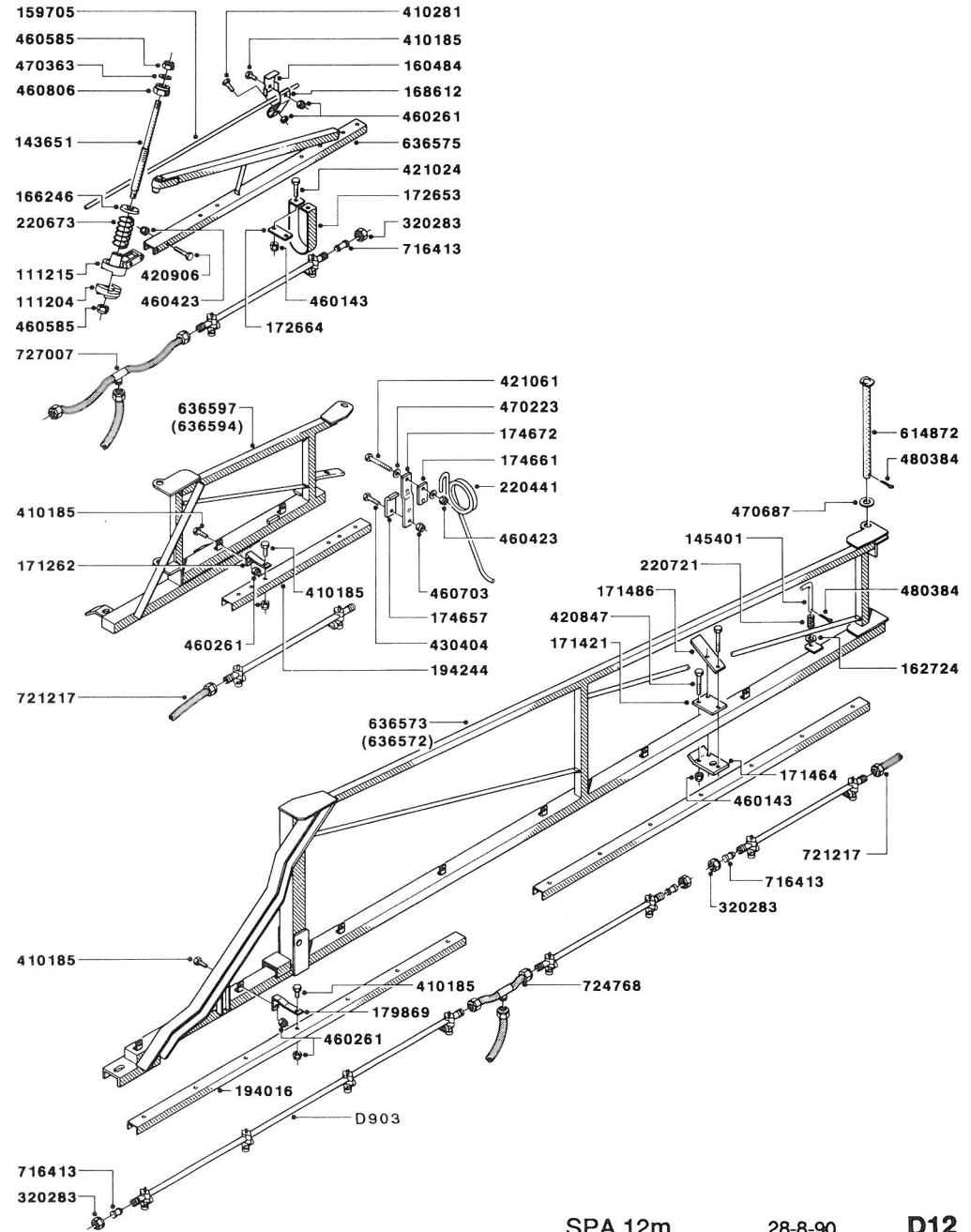

SPA 12m

28-8-90

D12

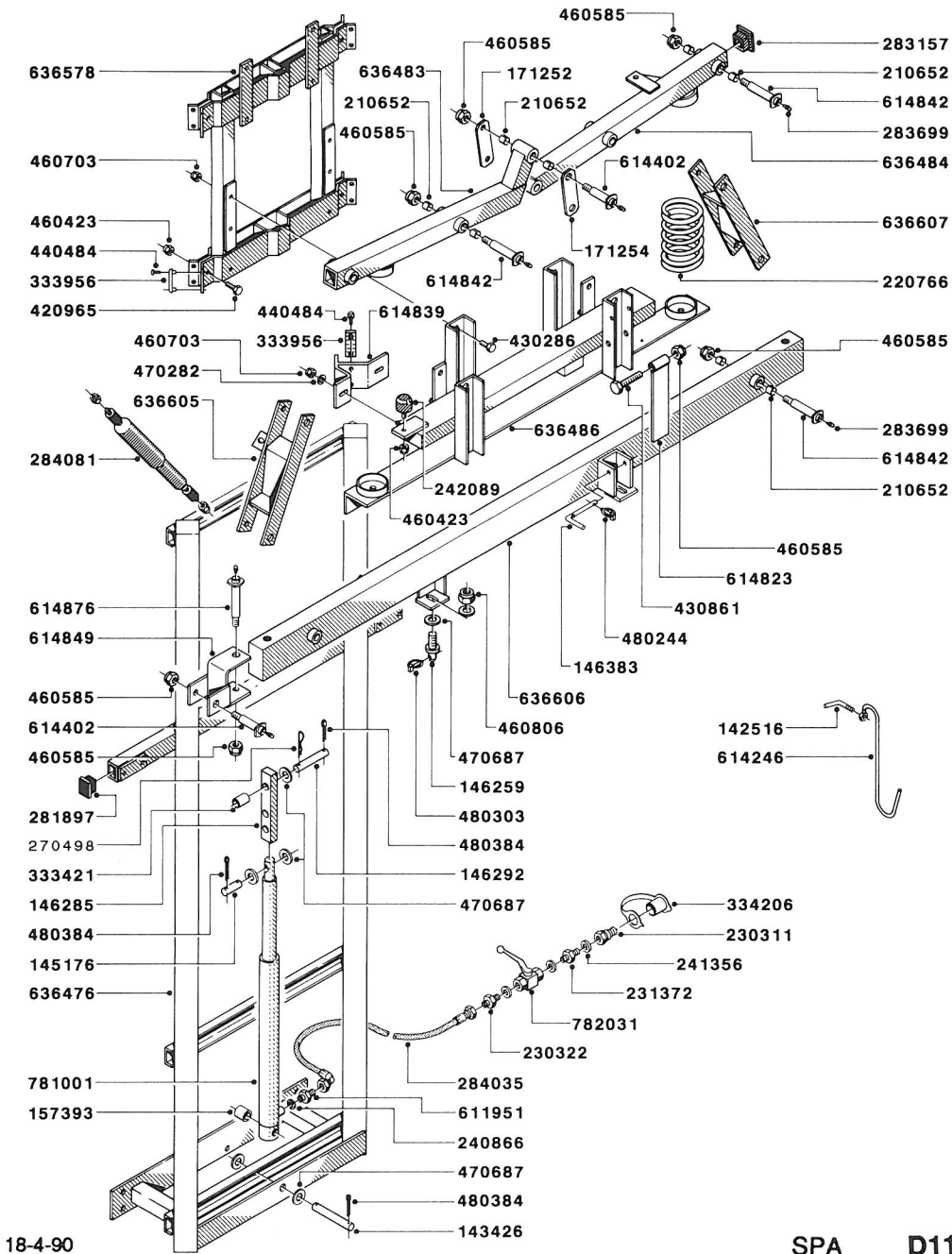

18-4-90

SPA D11

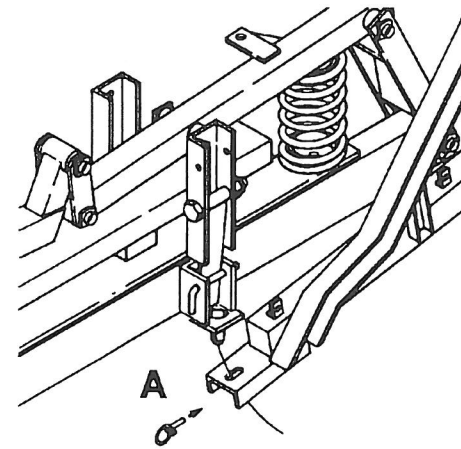

4. Lift boom so that it is locked into working position by the centre section pins. Replace the lynch pins (A).

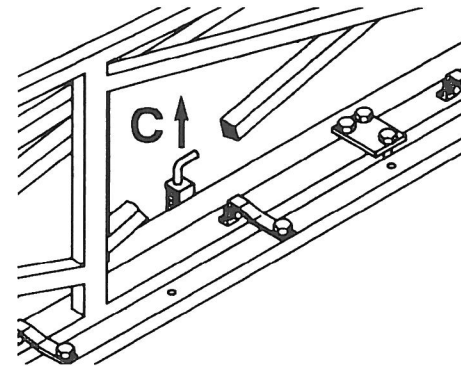
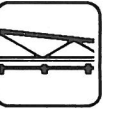

5. Go to intermediate/outer fold point. Pull spring loaded lock (C) up.

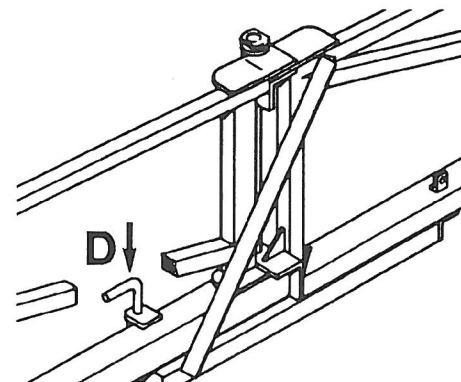

Unfold outer section until it locks (D).

6. Unfold breakaway.

Before reversing the procedure to fold the boom, set boom height so that it is approx. parallel to ground when resting in the transport brackets.



Operation of trapeze

The trapeze suspension of the boom must be correctly adjusted and regularly lubricated, if it is going to operate satisfactorily.

The primary function of the suspension is to protect the boom against vibrations and shocks and to keep it a uniform height above the target.

During normal operation in the field the lock plate (A) is folded up and secured with the holding pin (B). If you want to block the trapeze function, the plate is folded down and secured, eg. when folding the boom or when spraying on sloping terrain.

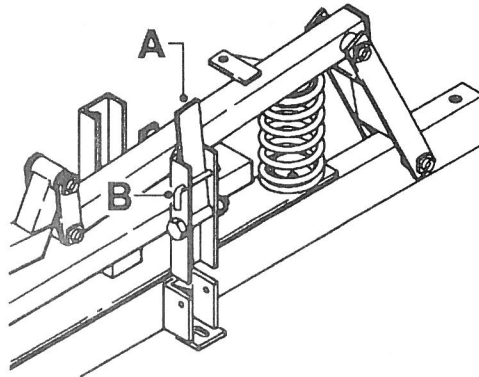

Boom damper location

The damper can be fitted on the right hand side (vertically) to slow or reduce vertical boom movement. It can also be fitted on the left hand side (inclined) to reduce lateral (trapeze) movement.

Boom damper is usually fitted on the left hand side but this depends on local conditions and position is best found by trial and error method.

To change location;
1. Loosen and remove upper and lower nuts (A), washers and rubber buffers.

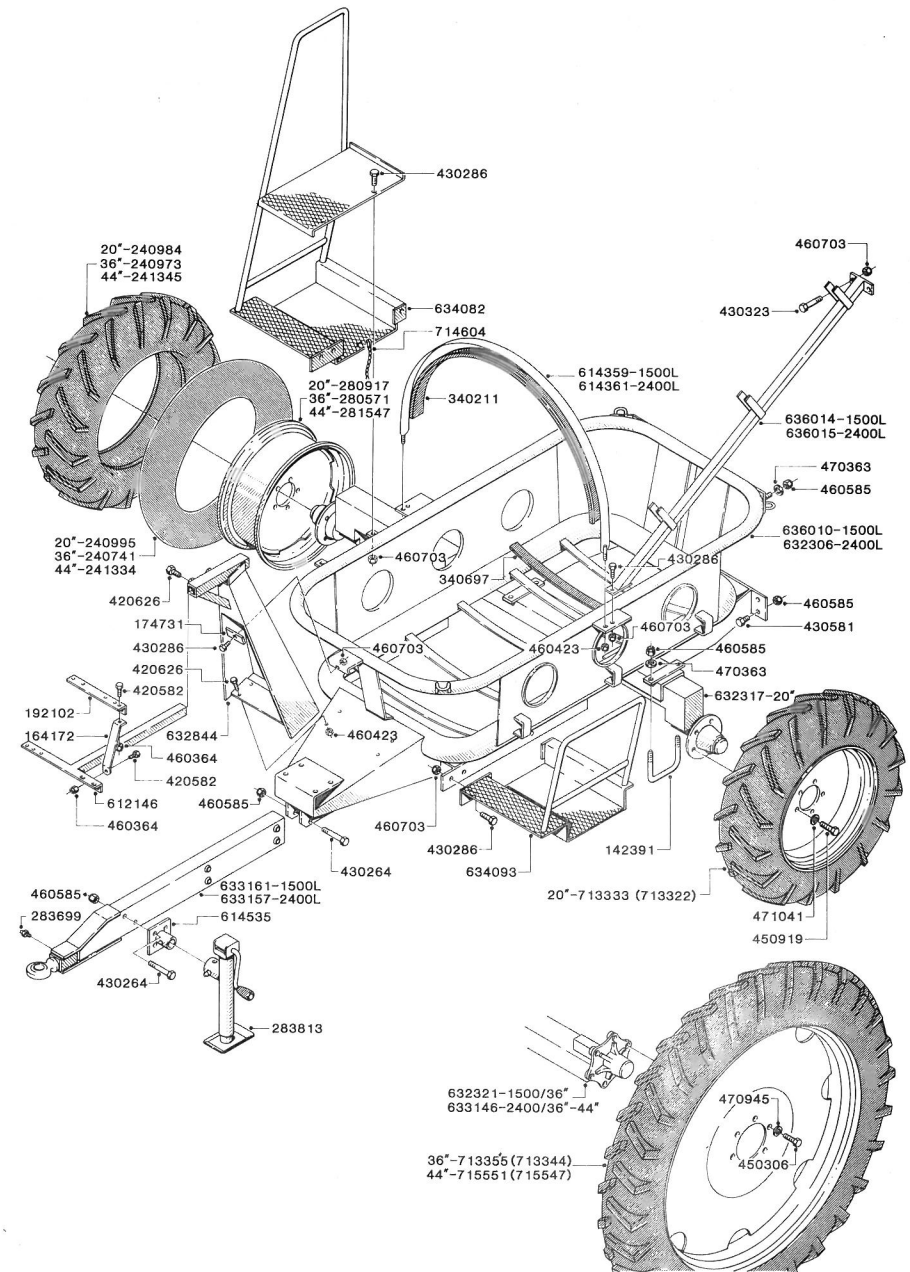
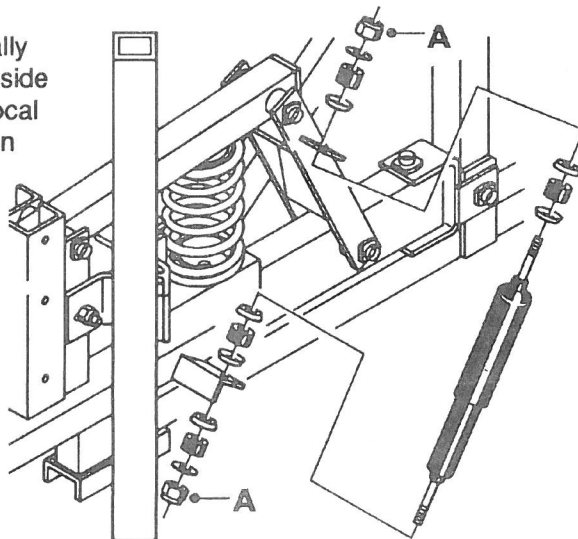

E301

2-1-86

TX 1500/2400

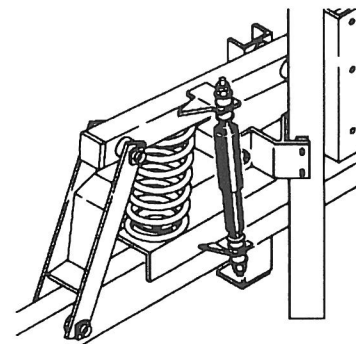
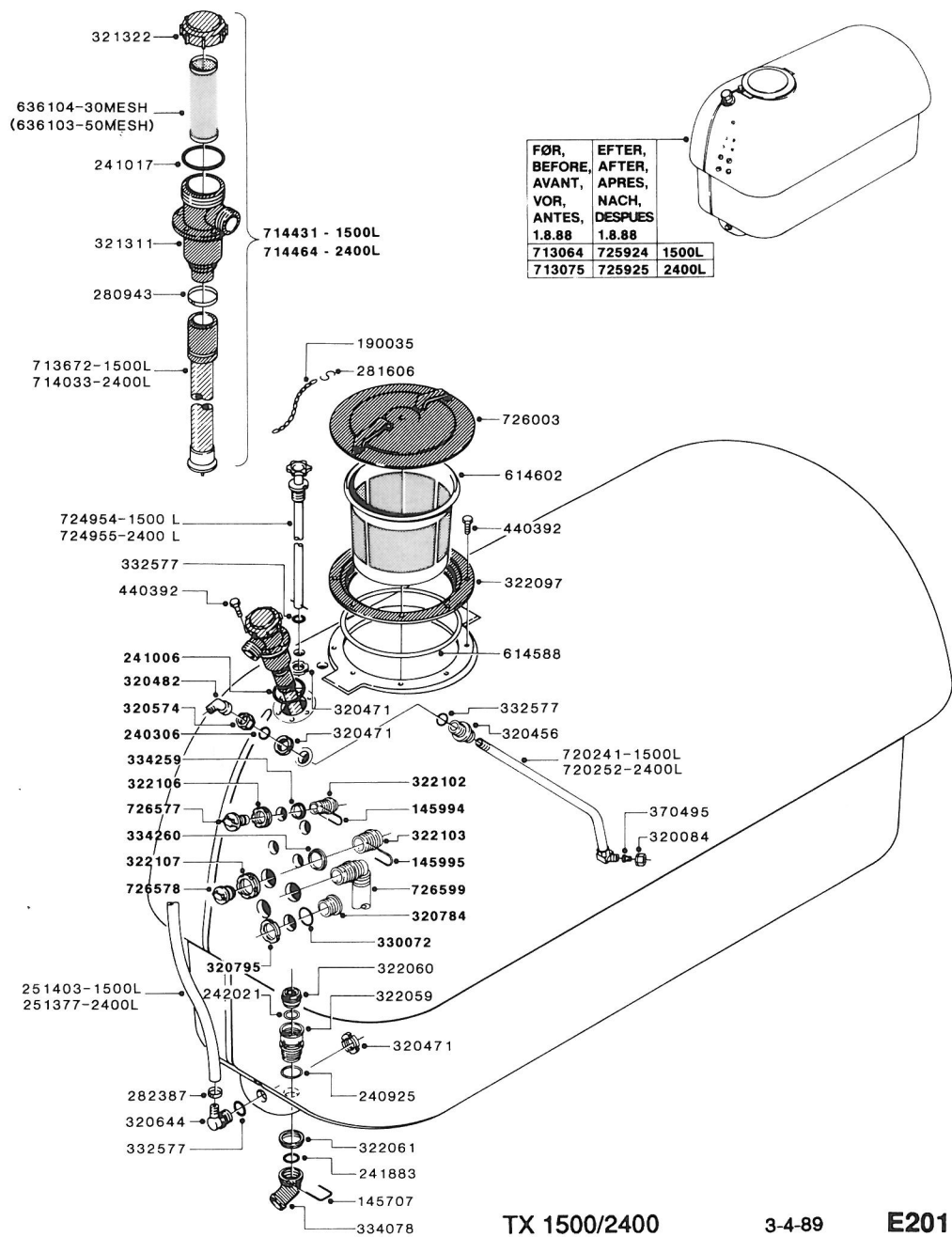

2. When fitting to other side, make sure washers and buffers are correctly fitted and damper is correct way up to prevent water from collecting inside the damper. Do not overtighten nuts.

Adjustment of operating unit

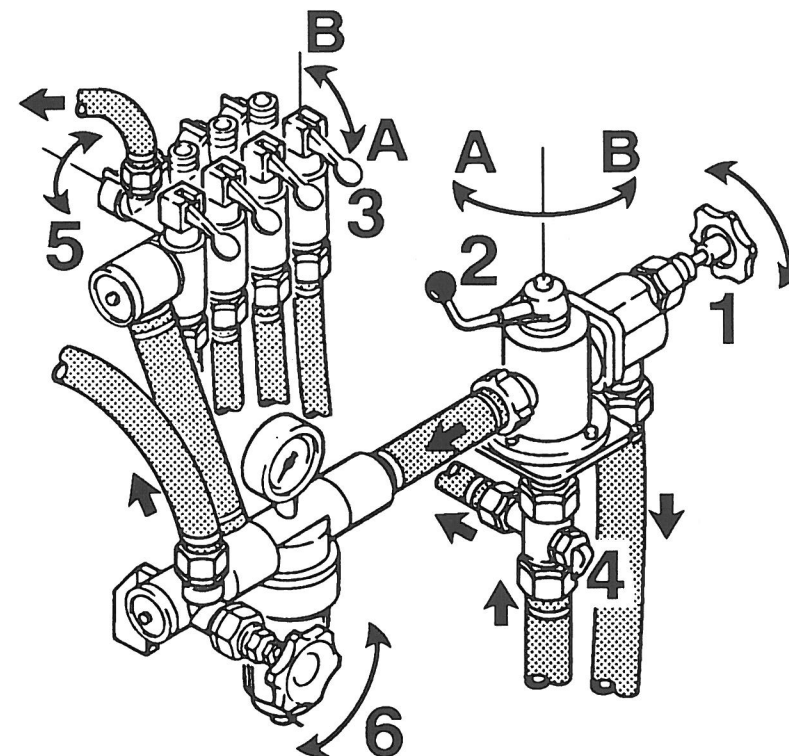

1. Open or close lever (4) depending on whether pressure agitation is required. (Remember pressure agitation takes 5% to 10% of pump output).

2. Turn main on/off handle (2) to spraying position (A).

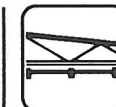



3. Set all hand levers (3) on the distribution valve to spraying position (A).
4. Turn the HARDI-MATIC valve (6) anti-clockwise to its extreme position.
5. Turn the safety valve (1) clockwise to maximum pressure setting.
6. Put the tractor in neutral and set the engine revolutions and thereby the number of revolutions of the pump corresponding to the intended travelling speed. Remember the number of revolutions on the P.T.O. must be kept between 300-600 r/min.

Adjust the HARDI-MATIC valve (6) so that the pressure gauge indicates the recommended pressure.

ADJUST THE PRESSURE EQUALIZATION SECTIONS AS FOLLOWS:

7. Note the pressure and place the first lever (3) on the distribution valve in position B (off position).
8. Turn the corresponding adjusting screw (5) until the pressure gauge again shows the same pressure (turn the screw clockwise for higher pressure, anti-clockwise for lower pressure).
9. Adjust the other sections of the distribution valve in the same way.

NOTE: HEREAFTER ADJUSTMENT OF PRESSURE EQUALIZATION WILL ONLY BE NEEDED IF YOU CHANGE TO NOZZLES WITH OTHER CAPACITIES.

10. Operating the control unit while driving:
To close the entire boom, turn the handle (2) to position B. This takes the pressure from the pump. The liquid will then return to the tank via the return system. The diaphragm anti-drip valves ensure instantaneous closing of all nozzles. In order to close part of the boom, move lever (3) of the distribution valve to position B (off position) for the section or sections to be closed. The pressure equalization device ensures that the pressure does not rise in the sections which remain open.

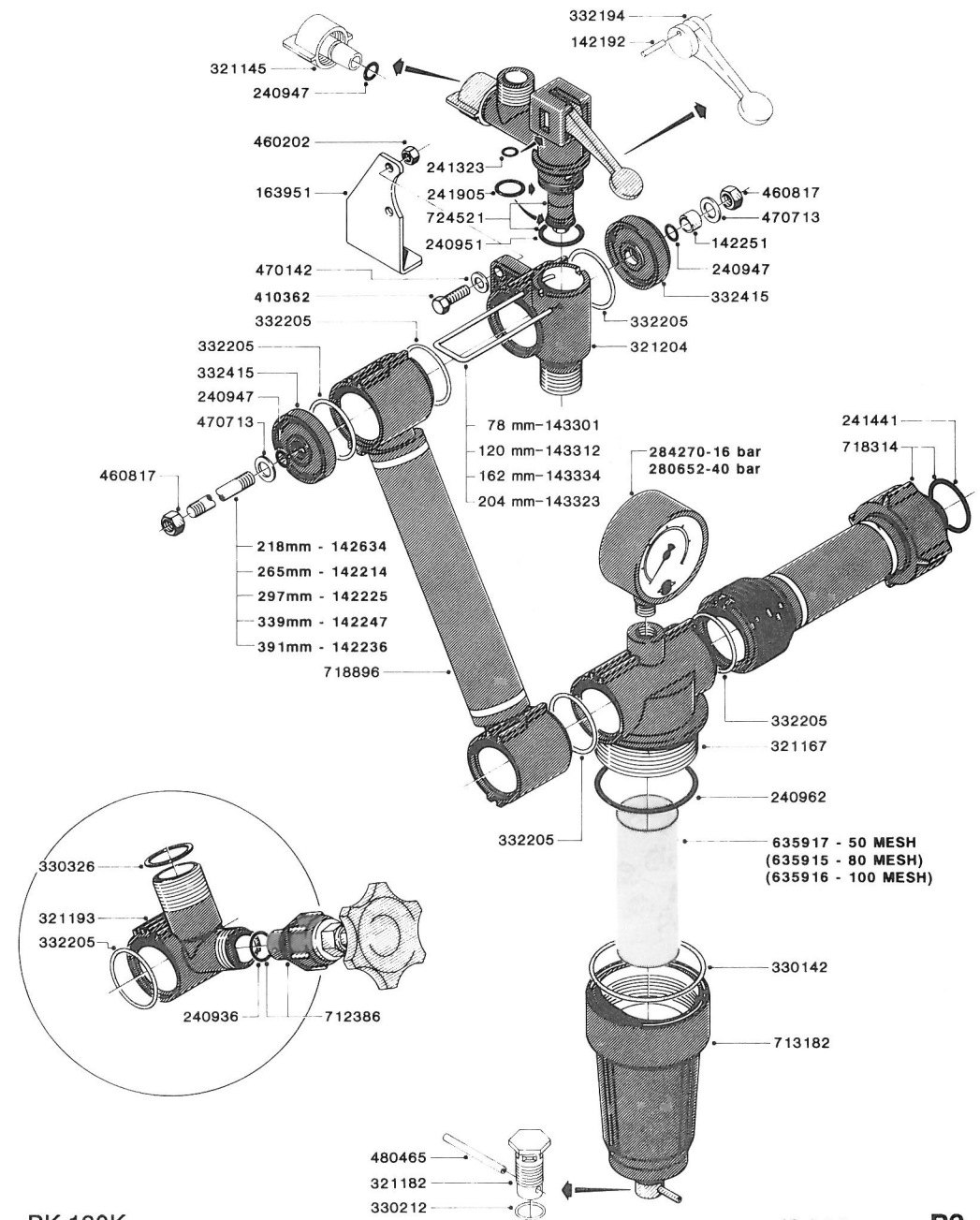

BK 180K

18-2-91

B9

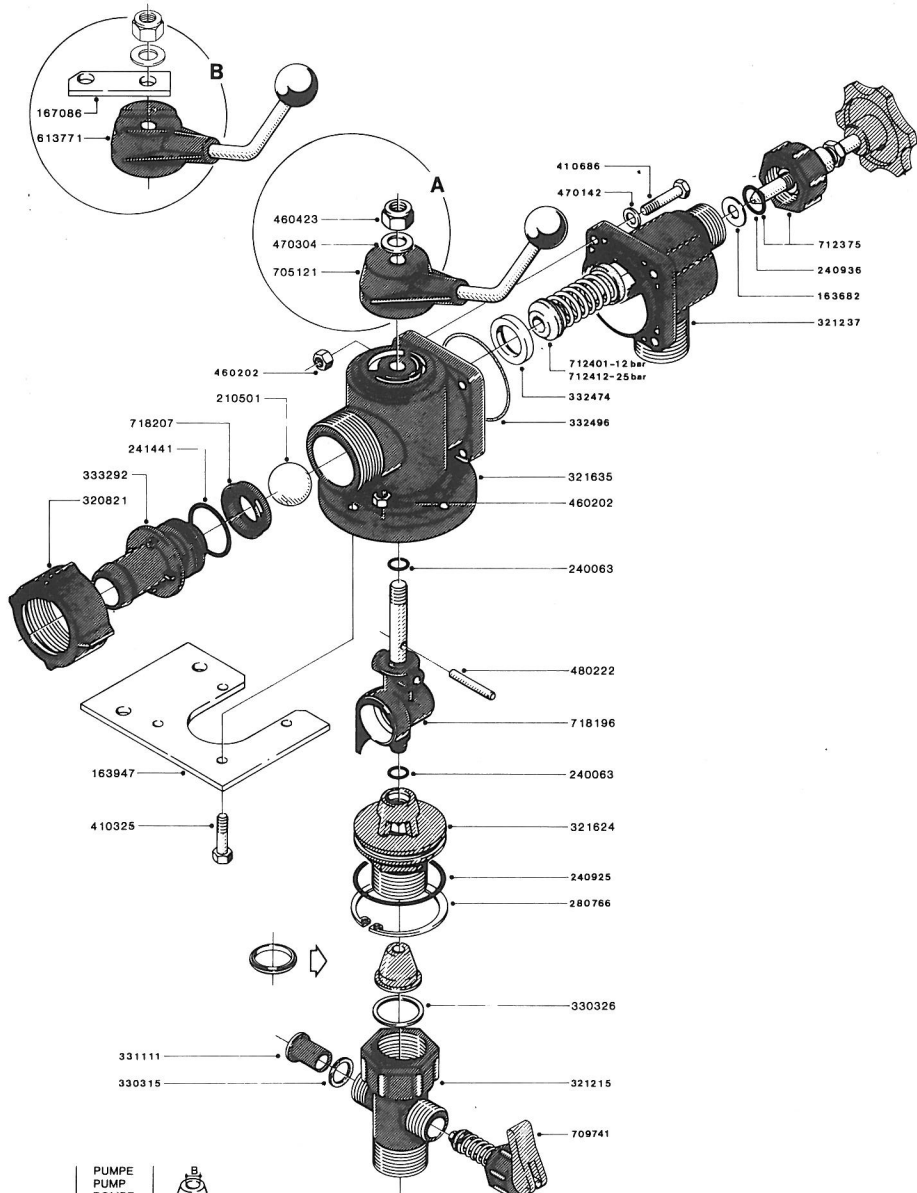

PUMPE	PUMP	POMPE	PUMPE	BOMBA	B	Ø mm	FARVE	COLOUR	COULEUR	FARBE	COLOR	
600	333314	5,2	BLÅ	BLUE	BLEU	BLAU	AZUL					
1200	333325	7,3	RØD	RED	ROUGE	ROJO						
1301	333336	10,0	HVID	WHITE	BLANC	WEISS	BLANCO					
361 HT	333347	9,6	ORANGE	ORANGE	ORANGE	ORANGE	ANARANJADO					
361	333351	12,5	SORT	BLACK	NOIR	SCHWARZ	NEGRO					
320 HT	333362	6	GRØN	GREEN	VERT	GRÜN	VERDE					
460												145305

2-4-87 B7

The operating unit has an in-built pressure filter. It is not necessary to dismantle the filter to clean it. When cleaning the sprayer (clean water circulating in tank), open the drain valve to flush the filter;

To open : A
To close : B

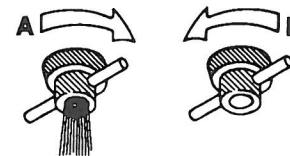

Operation of the tank

To open : A
To close : B



Spray Technique - see separate Spray Technique book.

Maintenance

In order to derive full benefit for many years from the sprayer, the following few but important rules should be kept:

Cleaning the Sprayer - see Spray Technique book.

Lubrication

Recommended lubrication is shown in following tables. Use ball bearing grease (lithium grease No. 2).

NOTE: If the sprayer is cleaned with a high pressure cleaner or it has been used to spray fertilizer, we recommend lubrication of the entire machine.





POS. ○ 7 Position on sprayer



Oil



Grease



Operation hours



Page to find more information



Winter protection

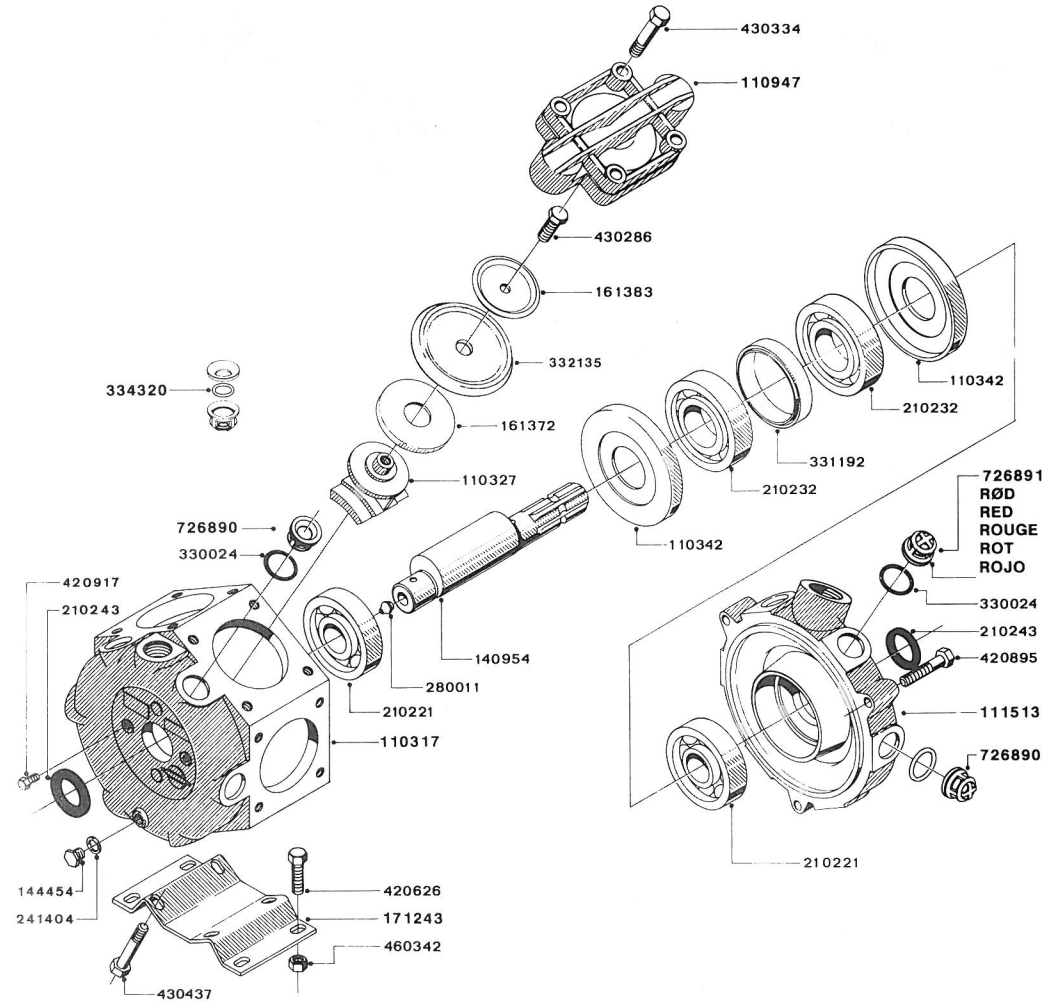
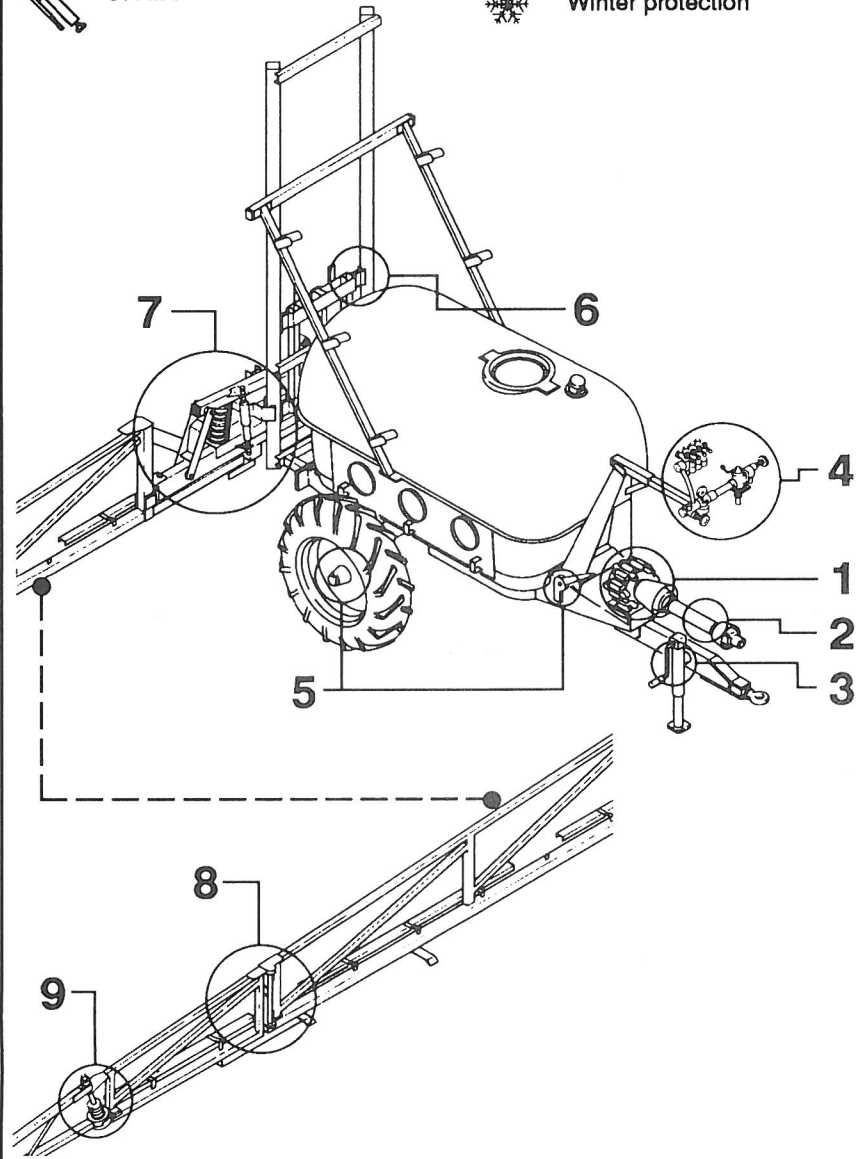



Pictorial symbols



Description



Function



Connection



Warning / Caution



Operation - liquid system



Service/adjustment



Operation - Boom



Pressure



Cleaning



Lubrication



Winter storage







Operational problems



Technical specifications

POS.					
1		X	40 		22 24
2		X	12		
A		X	40		
3		X	40		
4		X	20 		24

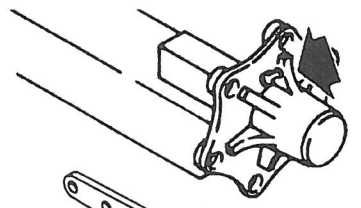
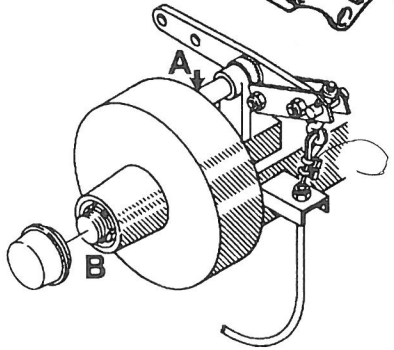
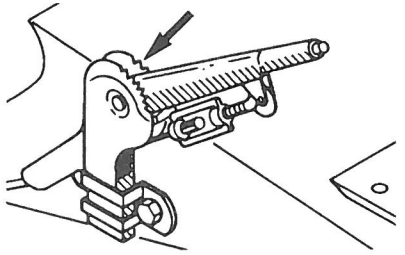
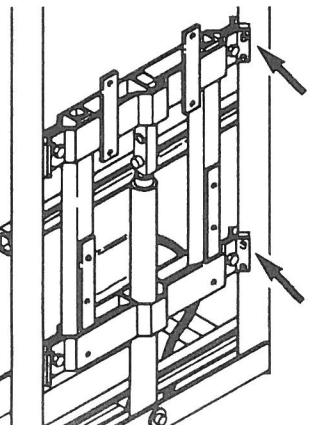
POS.					
5		X	1000		20
5 A		X	1000		21
B	X	1000			
5		X	40		21
6		X	40		21

Power consumption and capacity

Pump model 361

r/min	300		400		500		540		600		
	l/min	kW	l/min	kW	l/min	kW	l/min	kW	l/min	kW	
bar	0,0	91,0	1,79	121	1,87	150	2,00	161	2,11	174	2,21
	2,5	88,0	1,97	117	2,10	146	2,25	157	2,33	171	2,51
	5,0	87,5	2,09	116	2,28	144	2,50	155	2,61	169	2,80
	7,5	86,5	2,25	115	2,54	143	2,78	153	2,93	167	3,16
	10,0	86,0	2,43	113	2,77	141	3,10	152	3,29	165	3,56
Rotation per min.	r/min	Capacity			l/min	Suction height		0,0 m			
Power consumption	kW	Max. pressure		15 bar	Weight		54,0 kg				



Filters and nozzles

Pos.	Mesh/ colour	Description/ nozzle
1	30	Suction filter
2	50	Pressure filter
3	50 blue	Nozzle S 4110-16
4	50 blue	Nozzle S 4110-20

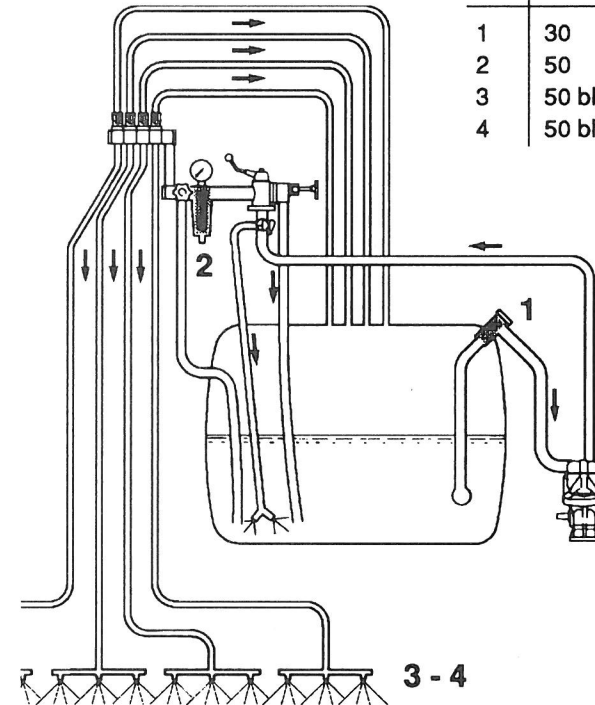



Technical specifications

Measure and weight

Tank size l	Wheel-size "	Spraying width m	Measure a x b x c cm	Weight kg *
1500	20	12	518 x 255 x 282	1050
		15	518 x 255 x 282	1150
		16	518 x 255 x 282	1160
		18	518 x 255 x 282	1180
	36	12	518 x 255 x 302	1090
		15	518 x 255 x 302	1190
2400	36	16	518 x 255 x 302	1200
		18	518 x 255 x 302	1220
		12	512 x 255 x 302	1260
		15	512 x 255 x 302	1360
	44	16	512 x 255 x 302	1370
		18	512 x 255 x 302	1390
		12	512 x 255 x 302	1290
		15	512 x 255 x 302	1390
	16	512 x 255 x 302	1400	
	18	512 x 255 x 302	1420	

* + 150 kg for model with parking brakes

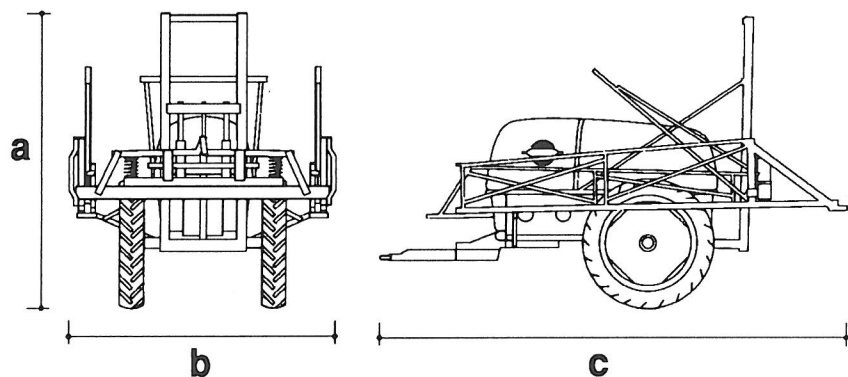

Boom height

TX 2400 with 36" wheels: Min./max.: 0.400/2.080 m

POS.					
7		X		40	18
8		X		40	
9	A	X	X	40	19
	B			40	



Re-adjustment of the boom

After having used the sprayer for some days the boom should be adjusted according to the following instructions:

When adjusting the boom and the trapeze the spray boom must be in the working position and the trapeze set in unlocked position. Sprayer must be on level ground.

1. Boom lift.

The boom lift should be adjusted so the boom can freely move up and down when the lift cylinder is actuated.

Adjust **A** so the space **B** is about equal at all 4 points. Do not overtighten **A**.
Now adjust **C** so the outer upright guide rest up against the gantry.

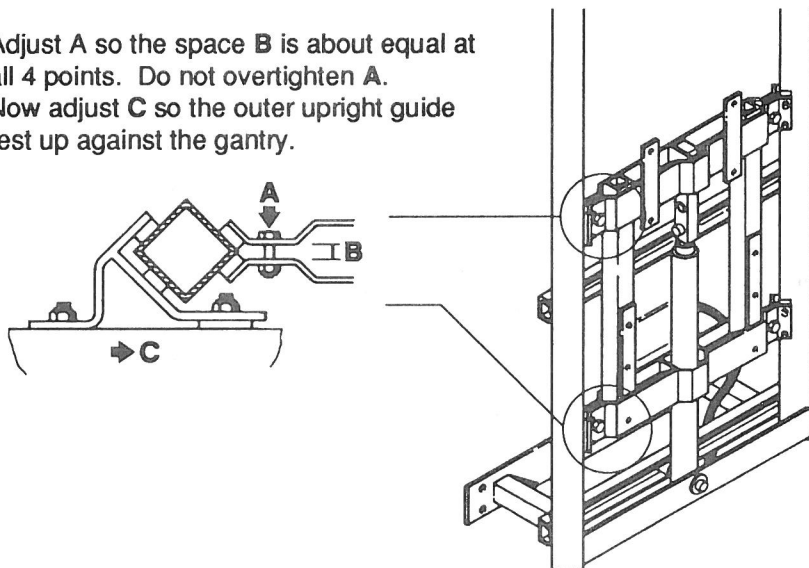

2. Trapeze suspension.

For the trapeze to function it must not be overtight. If it is too loose the boom will yawn (forward and back movement). This results in a poor spray distribution.

Adjustment is made after having lubricated all pivot points (see section „Lubrication“).



Fault	Probable cause	Control / remedy
Pressure increasing.	Pressure filters beginning to clog.	Clean all filters.
	Agitation nozzles clogged.	Check by turning agitation off / on.
Formation of foam.	Air is being sucked into system.	Check tightness / gaskets / O-rings of all fittings on suction side.
	Excessive liquid agitation.	Turn agitation off.
		Reduce pump r/min.
		Ensure return hoses inside tank are present.
	Use foam damping additive.	
Liquid leaks from bottom of pump.	Damaged diaphragm.	Replace. See „Changing of valves and diaphragms“.
Hydraulic system		
Hydraulic movements are fast / slow / erratic.	Air in system.	Loosen cylinder hose connection and activate hydraulics until oil flow has no air bubbles in it (not whitish).
	Insufficient hydraulic pressure.	Check output pressure of tractor hydraulics. Minimum for sprayer is 130 bar.
Cylinder not functioning.	Oil in tractor reservoir low.	Check and top up if needed.
	Sphere valve closed.	Reset sphere valve to correct position.
	Restrictor blocked.	Place boom in transport bracket. Secure boom from lowering. Remove hydraulic hose nipple and restrictor and clean.



Fault	Probable cause	Control / remedy
Liquid system		
No spray from boom when turned on.	Air leak on suction.	Check if red suction lid / O-ring are sealing. Check suction tube and fittings. Check tightness of pump diaphragm and valve covers.
	Air in system.	Fill suction hose with water for initial prime.
	Suction / pressure filters clogged.	Clean filters. Check yellow suction pipe is not obstructed or placed too near the tank bottom.
Lack of pressure.	Incorrect assembly.	Agitation nozzles not fitted. Too little distance between yellow suction pipe and tank bottom.
	Pump valves blocked or worn.	Check for obstructions and wear.
	Defect pressure gauge.	Check for dirt at inlet of gauge.
Pressure dropping.	Filters clogging.	Clean all filters. Fill with cleaner water. If using powders, make sure agitation is on.
	Nozzles worn.	Check flow rate and replace nozzles if it exceeds 10%.
	Tank is airtight.	Check vent is clear.
	Sucking air towards end of tank load.	Excessive agitation, turn off. Returns inside tank need relocation.

Adjust trapeze bolts **A** so that the trapeze is not too tight nor too loose when trapeze is not locked. Minor adjustment in the field may be necessary.

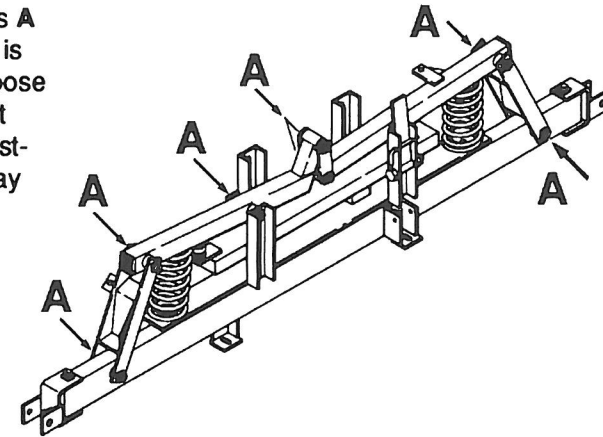

3. Breakaway.
The function of the breakaway is to prevent or reduce boom damage should it strike an object or the ground. If it is overtight, it will not function. If it is too loose, it will yawn under spraying.

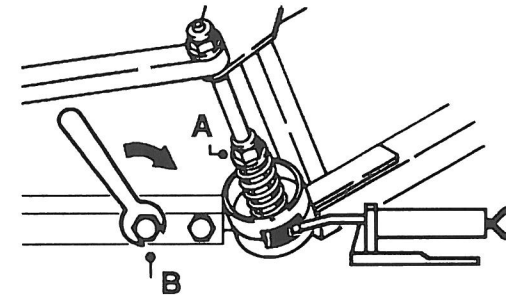

Lubricate coupling before adjusting spring tension. Slacken nut **A** to decrease breakaway resistance. Do not overtighten; better too loose than overtight. Again minor adjustments in the field may be necessary.

Ensure also channel bolts **B** are tight.

4. Horizontal level
After some usage the boom may settle resulting in the boom tips being lower than the boom centre. To compensate for this, the washers on the upper side of the pin (**A**) can be moved to the lower side.

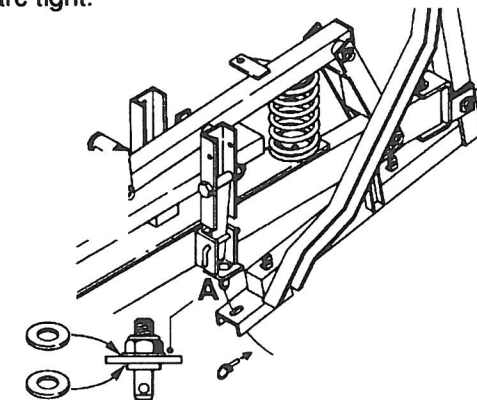



Recommended tyre pressure

The tyres should not run under-inflated. This only promotes instability and rapid wear.

Tyre size:	Maximum pressure:
9,5 x 20"	2,4 bar (34 psi)
9,5 x 36"	3,8 bar (54 psi)
9,5 x 44"	3,0 bar (43 psi)

The pressure is specified for a full loaded trailer. When travelling on hard road surfaces with maximum load, do not exceed 10 km/h. Remember it is easier to let off a little pressure for a specific use than to re-inflate a tyre in mid-field.



Wheel nuts and bearings

Check wheel nut tension after the first 8 working hours (hereafter „hours“).

Thread	Spanner size (mm)	Torque (Nm)
M18 x 1.5	24	260
M20 x 1.5	27	340
M22 x 2.0	32	420

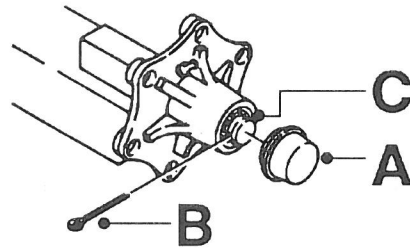

Check roller bearing slack after the first 8 hours and 50 hours. Thereafter every 100 hours.

If necessary, adjust as follows;

1. Jack wheel up. It is best to remove the wheel.
2. Remove hub cap (A) and split pin (B).
3. Shaft nut (C) is tightened until slight rotation resistance of drum is noted (check it is not the brake linings).
4. Now loosen shaft nut until first split pin hole is visible.
5. Insert split pin and replace hub cap.

After 1000 hours or once a year, the axle bearings are greased.

Operational problems

In cases where breakdowns have occurred the same factors always seem to come into play:

- Minor leaks on the suction side of the pump will reduce the pump capacity or stop the suction completely.
- A clogged suction filter will hinder or prevent suction so that the pump does not operate satisfactorily.
- Clogged up pressure filters will result in increasing pressure at the pressure gauge but lower pressure at the nozzles.
- Foreign bodies stuck in the pump valves with the result that these cannot close tightly against the valve seat. This reduces pump efficiency.
- Poorly reassembled pumps, especially diaphragm covers will allow the pump to suck air resulting in reduced or no capacity.
- Hydraulic components that are contaminated with dirt result in rapid wear to the hydraulic system.

Therefore ALWAYS check:

1. Suction, pressure and nozzle filters are clean.
2. Hoses for leaks and cracks, paying particular attention to suction hoses.
3. Gaskets and O-rings are present and in good condition.
4. Pressure gauge is in good working order. Correct dosage depends on it.
5. Operating unit functions properly. Use clean water to check.
6. Hydraulic components are maintained clean.





Winter storage

When the spraying season is over you should devote some extra time to the sprayer before it is put away for the winter.

Hoses

Check that none of the hoses are caught or have sharp bends.

A leaky hose can give an annoying delay in the middle of the spraying job. Therefore check all the hoses and change if there is any doubt about the durability.

Paint

Some chemicals are very hard on paints. It is therefore well advised to remove rust, if any, and then touch up the paint.

Tank

Check that no chemical residues are left from the last spraying. Chemical residues must not be left in the tank for a long time. It will reduce the life of the tank. See Spray Technique book- Cleaning Field Sprayers

Operating unit

Check that the safety valve is completely loosened. The spring is thereby relieved and operation difficulties are avoided at start-up next season.

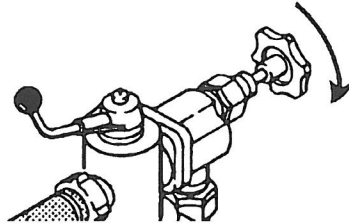

Transmission shaft

Check that the transmission shaft shields fulfill their security purpose, e.g. that shields and protective tubes are intact.

Anti-freeze precaution

If the sprayer is not stored in a frost-proof place you should take the following precautions: Put at least 10 litres of 33% anti-freeze mixture in the tank and let the pump run a few minutes so that the entire system including nozzle tubes are filled. Remove the glycerine filled pressure gauge and store it frost free in vertical position. The anti-freeze solution also hinders the O-rings and gaskets from drying out.

Adjustment of brakes

As the brake linings wear it may be necessary to adjust the position of the brake arm. Initial check is made at 100 hours.

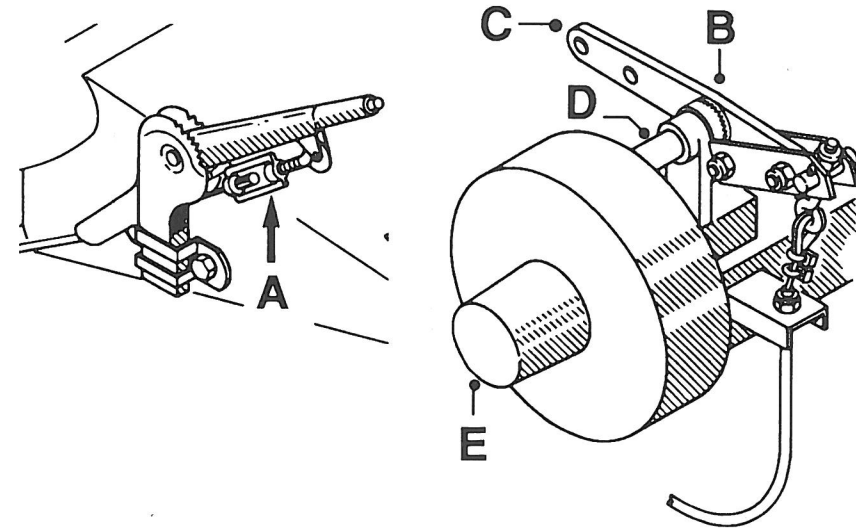

1. Slacken the hand brake cable (A).
2. Loosen nut (B) holding brake arm (C) to cam shaft (D) entering brake drum.
3. Loosen brake arm (C) so the grooved washers are freed.
4. Rotate cam shaft (D) as if braking (use a pipe wrench) until wheel just turns smoothly.
5. Refit brake arm (C) and nut.
6. Take slack from hand brake cable (A).

Cam shaft (D) is to be greased after the initial 100 hours and thereafter 1000 hours or once a year.

After 1000 hours or once a year, the axle bearings are greased and brake linings checked. Remove hub cap (E) to grease bearings. The brake drum must be removed before the linings can be checked. See section on „Wheel nuts and bearings“. Replacement must take place before the brake lining rivets contact the brake drums.





Changing of valves and diaphragms

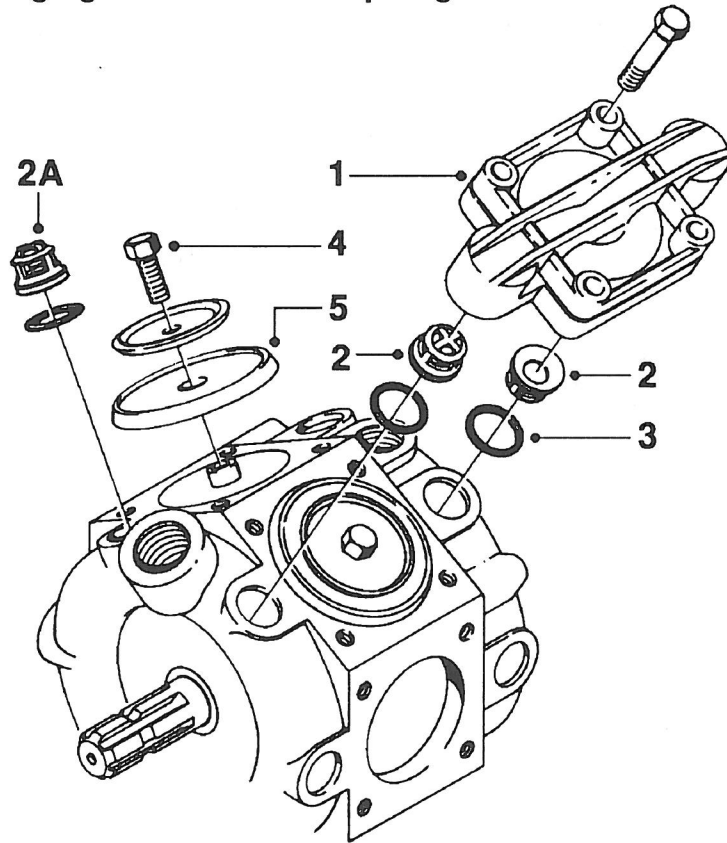

Valves

Remove valve compartment (1). Before changing the valves (2) note the orientation of the valves so that they are replaced correctly.

Important: Note valve with red flap (2A) is placed in the valve opening shown.

It is recommended to use new O-rings (3) when changing or checking the valves.

Diaphragms

Remove valve compartment (1). Remove bolt (4). The diaphragm (5) may then be changed. If fluids have reached the crankcase, re-grease the pump thoroughly. Check also the drain hole at bottom of pump is not blocked.

Level indicator

Depending on products used, it may become difficult to see the spray liquid inside the level indicator tube.

Note that the tube can be replaced when necessary.

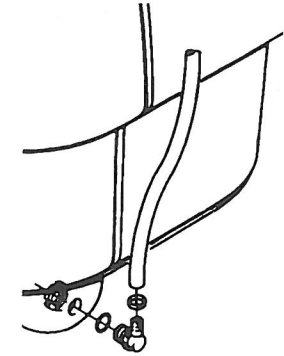

Nozzle tubes and fittings

Poor seals are usually caused by;

- missing O-rings or gaskets
- damaged or incorrectly seated O-rings
- dry or deformed O-rings or gaskets
- foreign bodies

Therefore, in case of leaks: **DO NOT** overtighten, disassemble, check condition and position of O-ring or gasket, clean lubricate and reassemble.

For **radial** connections only hand tighten them.

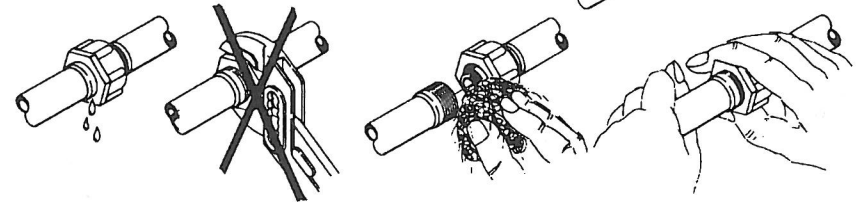

The O-ring must be lubricated **ALL THE WAY ROUND** before refitting.

For **face** connections, a little mechanical leverage may be used.

