

| Km/h | 25 | 40 |
|-------|----|----|
| 17/39 | X | X |
| 17/40 | | X |
| 21/39 | X | X |
| 21/40 | | X |
| 23/45 | X | |

Kit **CLINAIR**[®]
CLINAIR[®] kit
 232 771 000

Lampe à iode
 Iodine lamp
 REF 234 747 000
 234 744 000

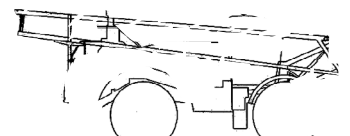
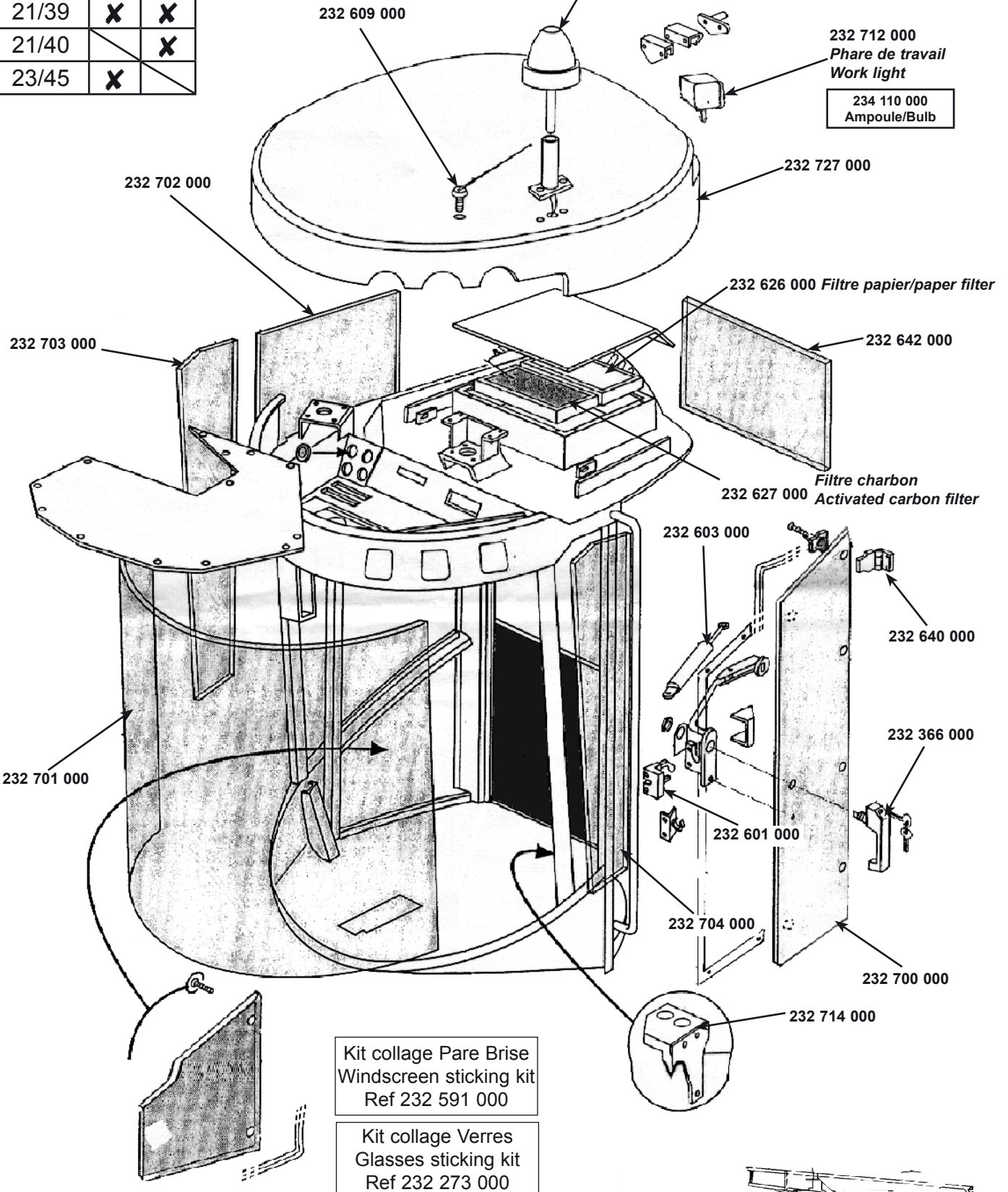

| Km/h | 25 | 40 |
|---------|----|----|
| Modèles | | |
| 17/39 | X | X |
| 17/40 | | X |
| 21/39 | X | X |
| 21/40 | | X |
| 23/45 | X | |

Cache/ expansion slot cover
162 484 000

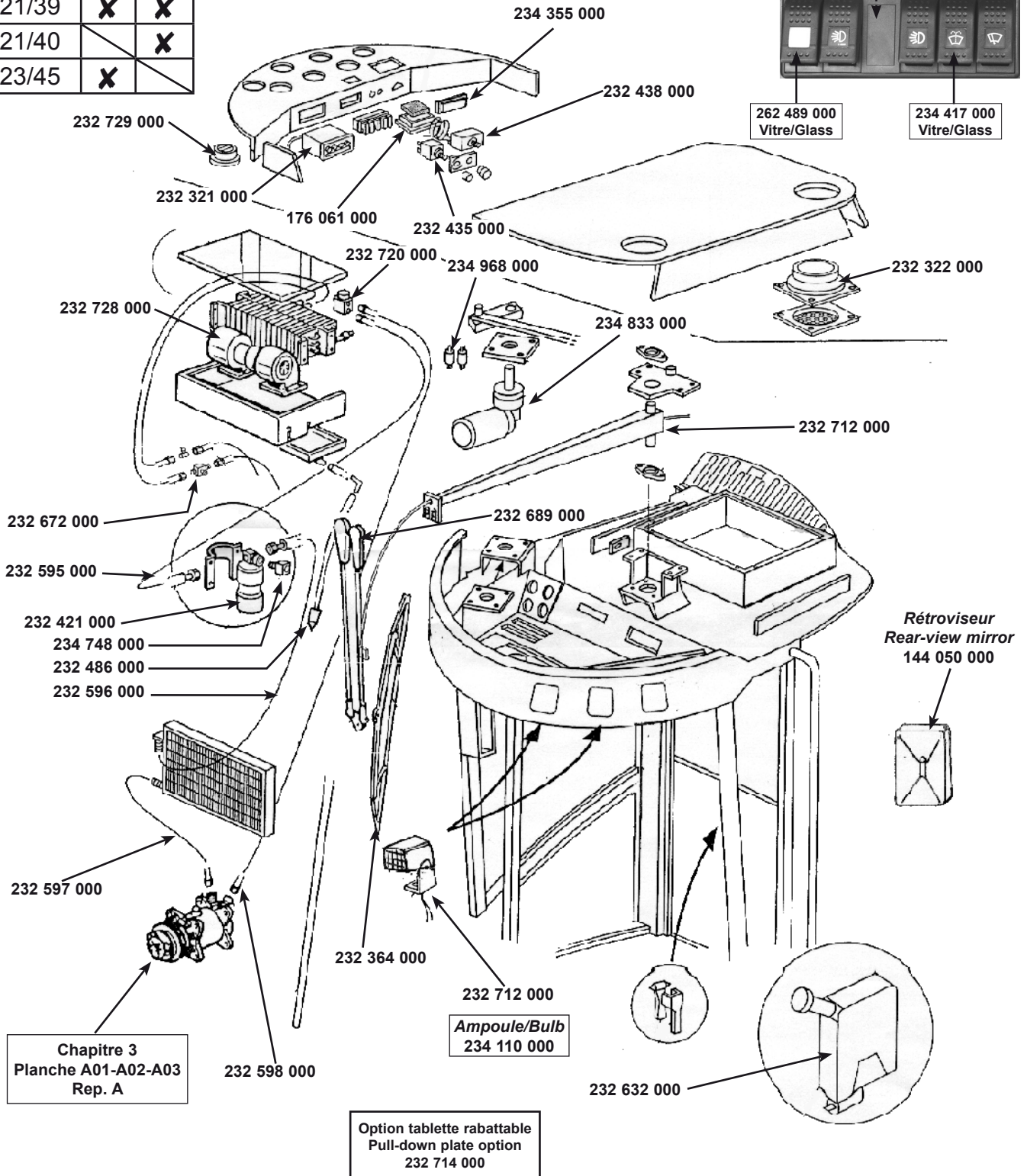
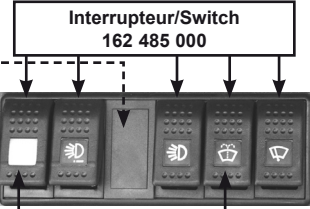

Chapitre 3
Planche A01-A02-A03
Rep. A

Option tablette rabattable
Pull-down plate option
232 714 000

Rétroviseur
Rear-view mirror
144 050 000

| Km/h Modèles | 25 | 40 |
|-----------------|----|----|
| 17/39 | X | X |
| 21/39 | X | X |
| 23/45 | X | |

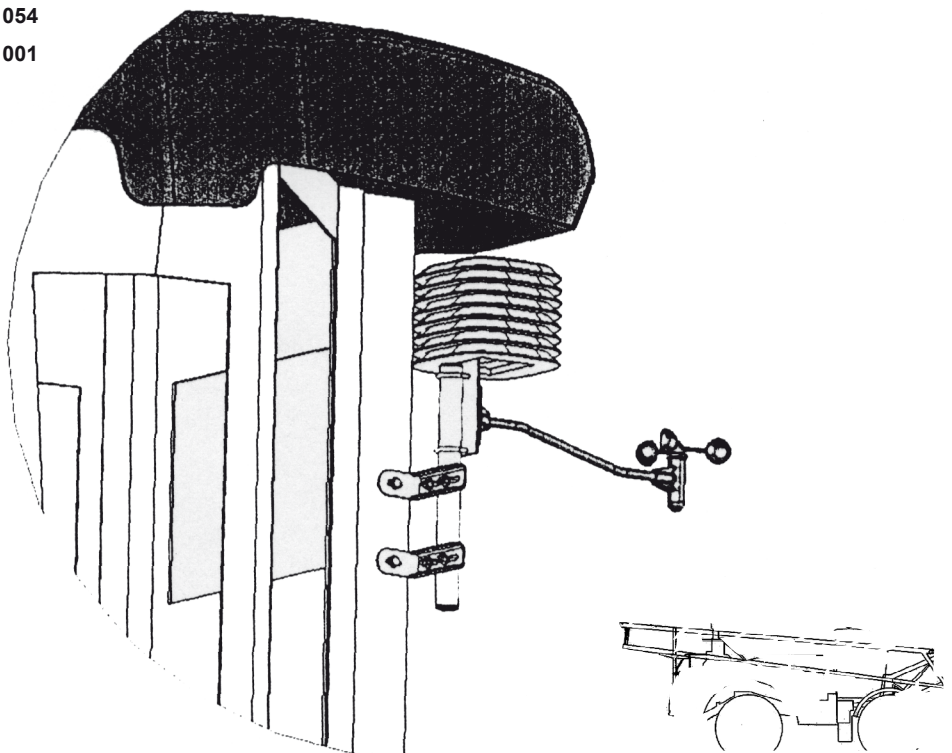
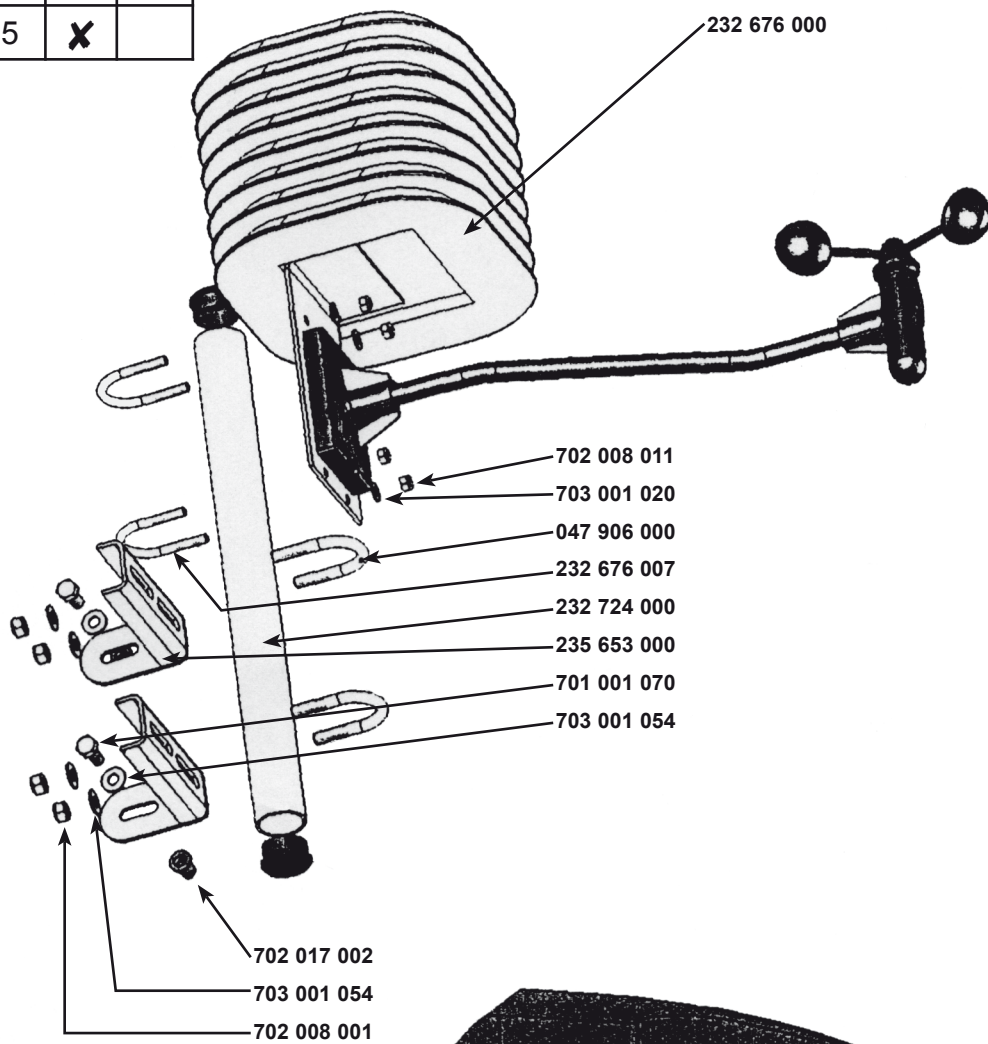

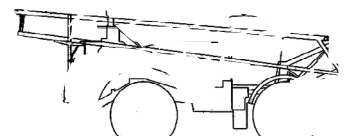
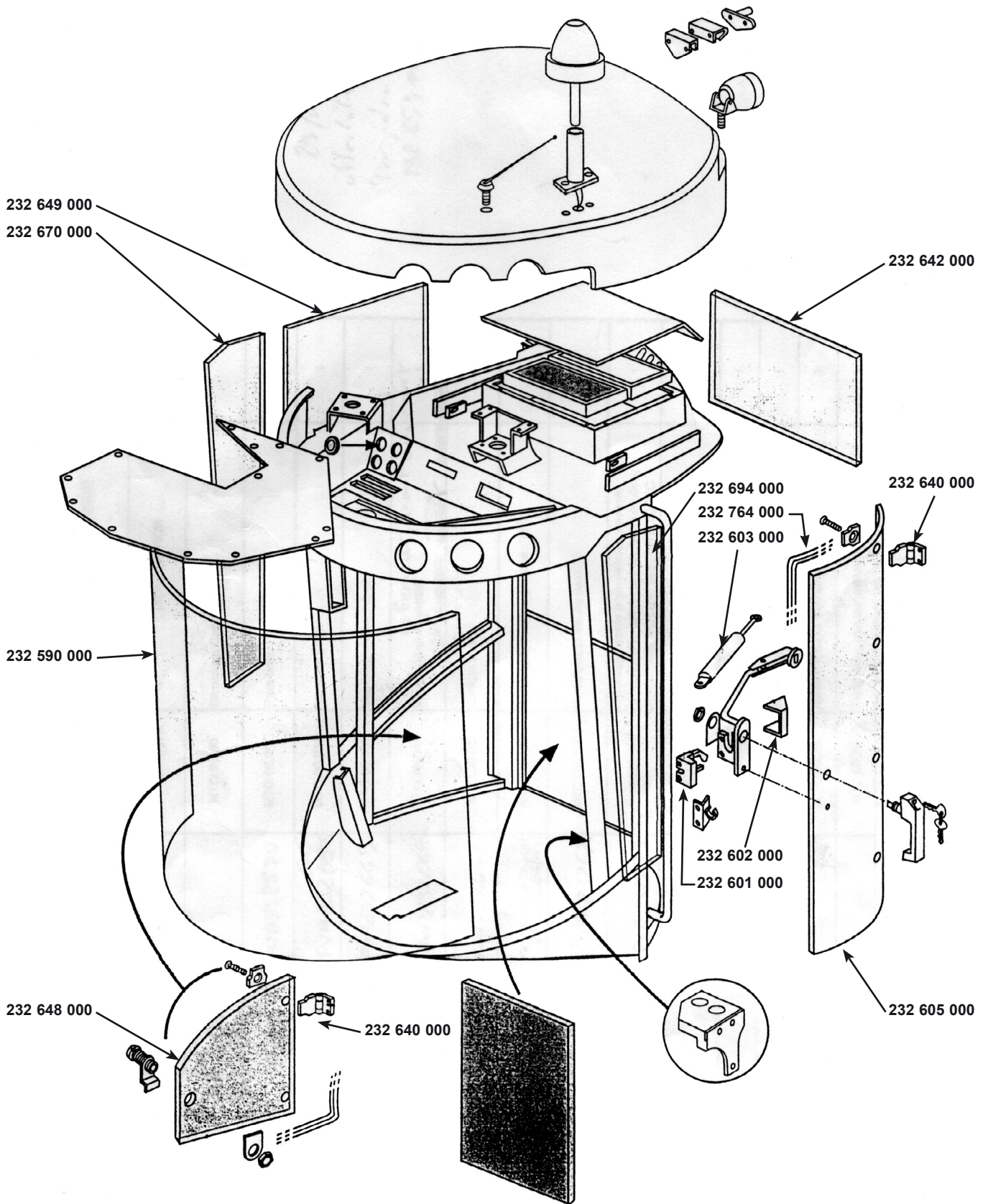

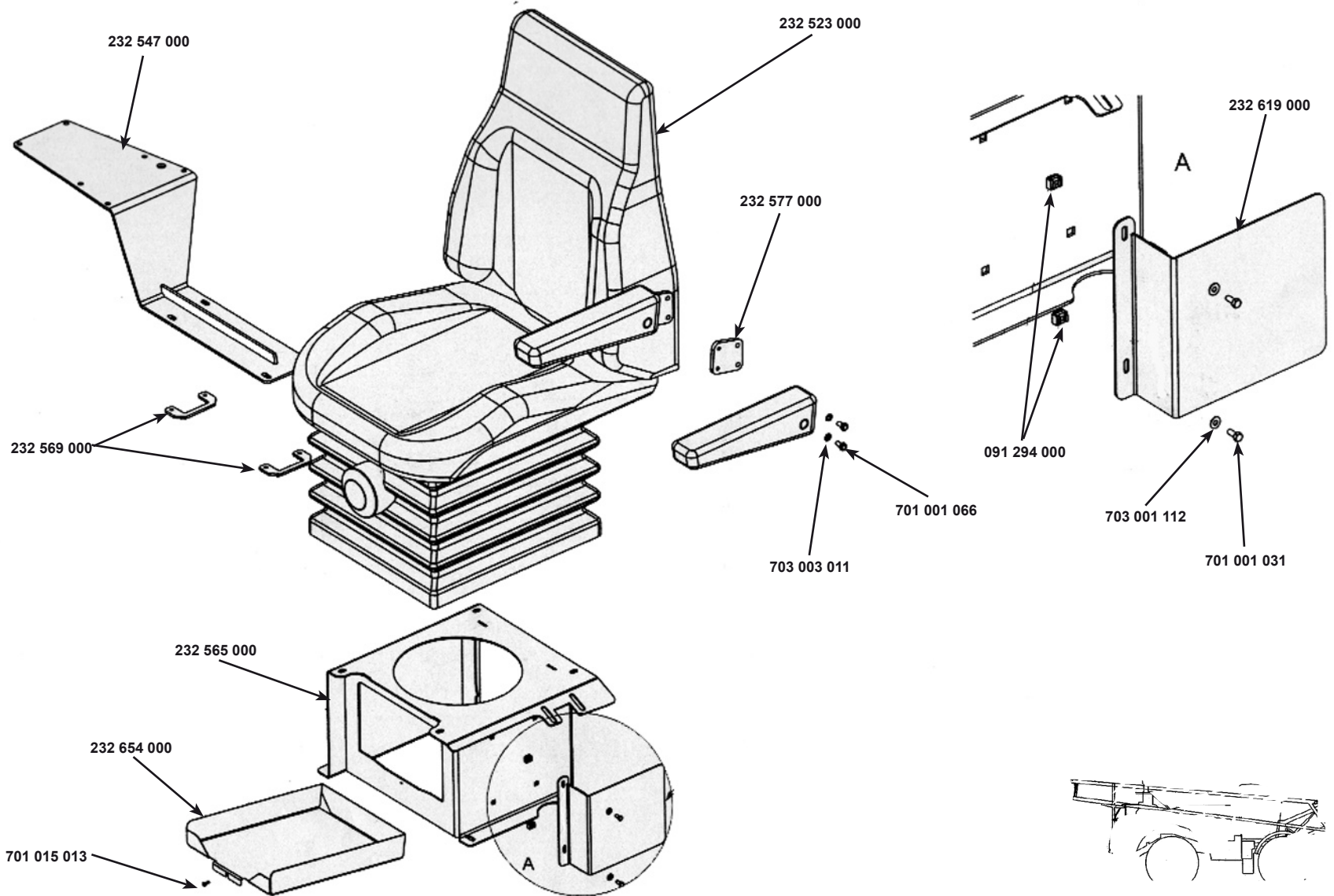

| Km/h | 25 | 40 |
|-------|----|----|
| 17/39 | X | X |
| 21/39 | X | X |
| 23/45 | X | |

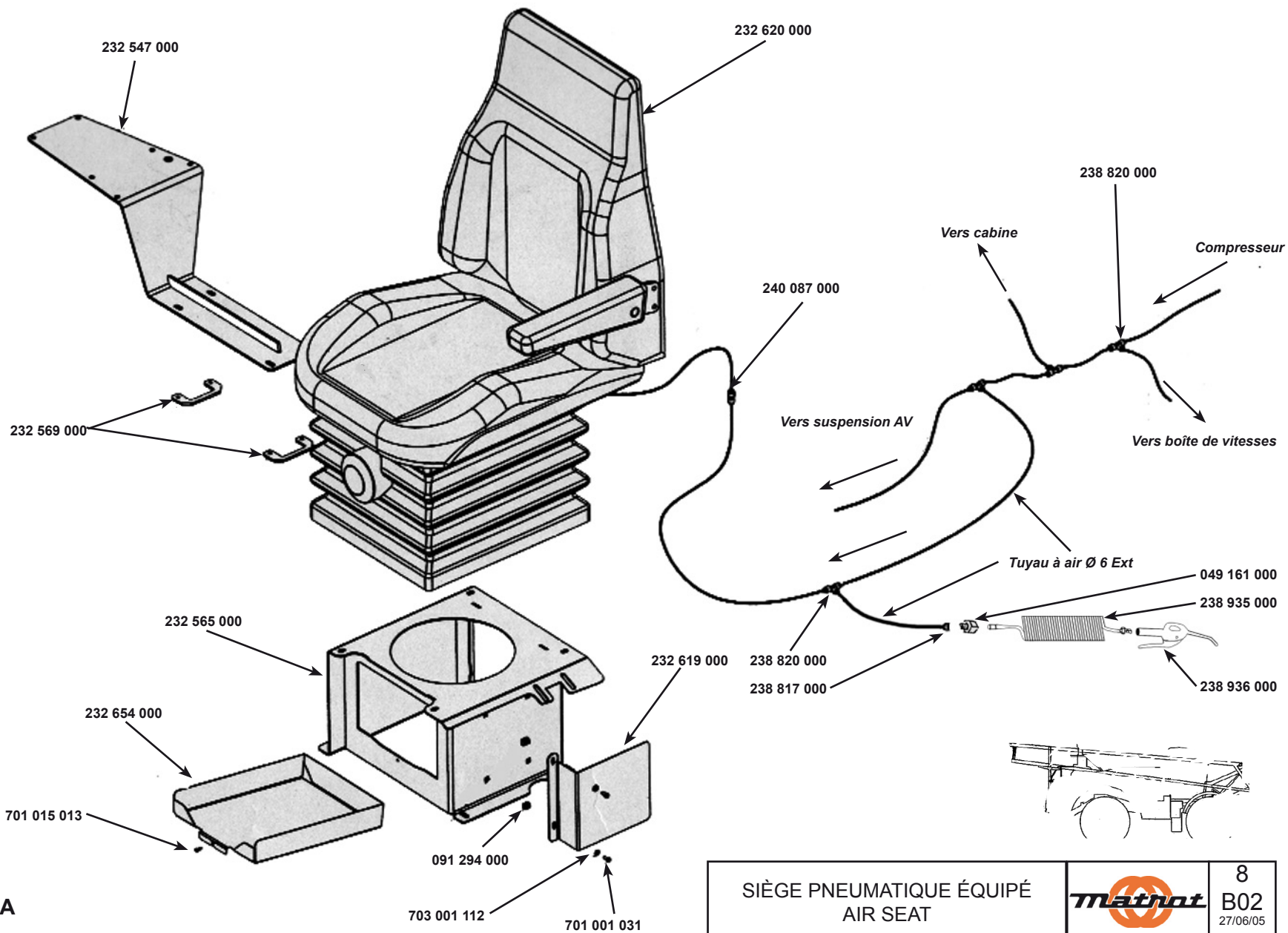

| Km/h | 25 | 40 |
|-------|----|----|
| 17/39 | X | X |
| 21/39 | X | X |
| 23/45 | X | |



CATALOGUE MAESTRIA
RAMPE AV 2004

| | | |
|--------------------------------------|---|----------------------|
| SIÈGE PNEUMATIQUE ÉQUIPÉ AIR SEAT |  | 8 B02 27/06/05 |
|--------------------------------------|---|----------------------|

| Km/h Modèles | 25 | 40 |
|-----------------|----|----|
| 17/39 | X | X |
| 21/39 | X | X |
| 23/45 | X | |

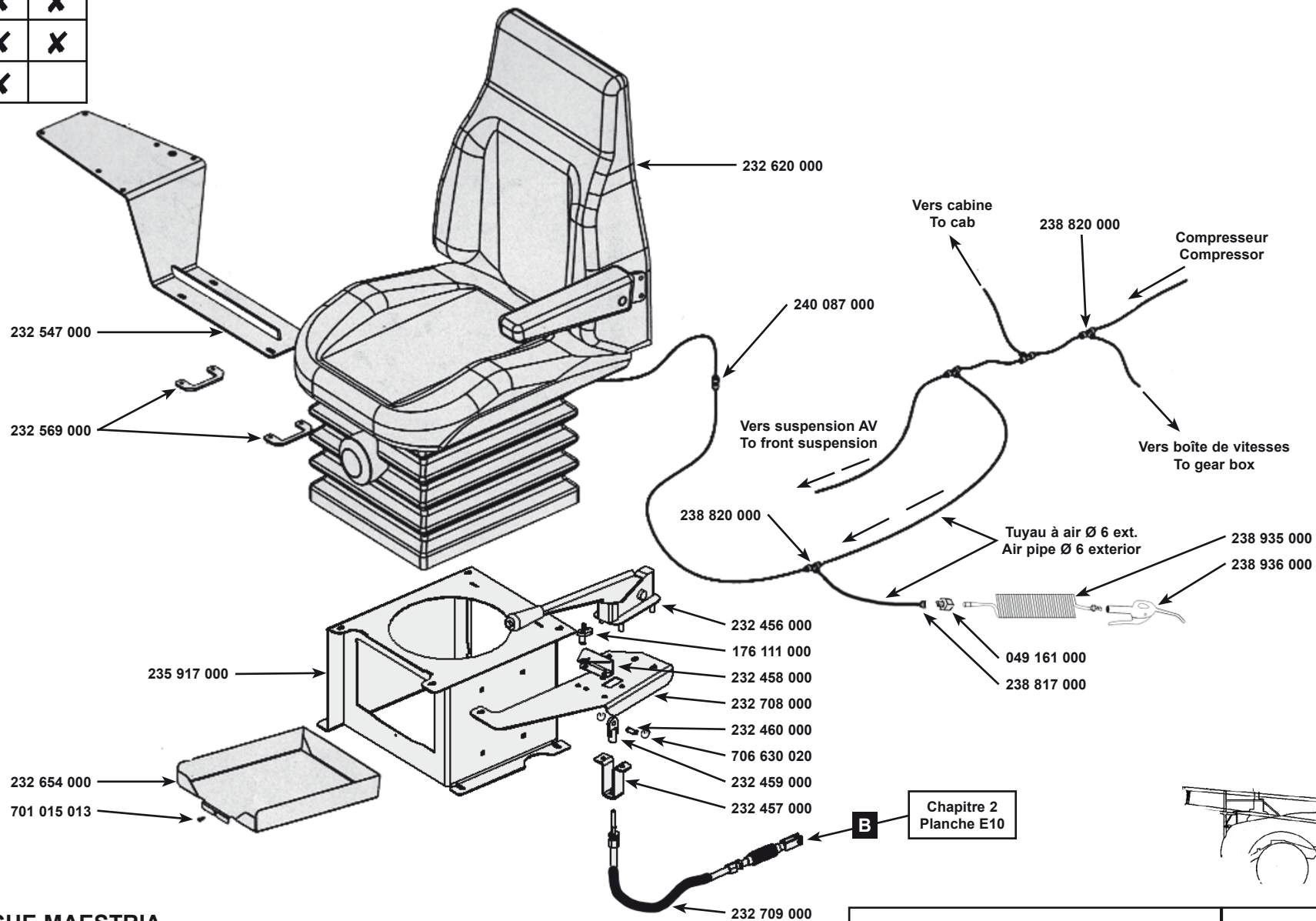

CATALOGUE MAESTRIA
RAMPE AV 2004
 Ajout mars 2006/March '06 Add-on

| | | |
|---|--|----------------------|
| SIÈGE PNEUMATIQUE STABILIS® STABILIS® PNEUMATIC SEAT | | 8 B03 03/04/06 |
|---|--|----------------------|

| Modèles | Km/h | 25 | 40 |
|---------|------|----|----|
| 17/39 | | X | X |
| 17/40 | | | X |
| 21/39 | | X | X |
| 21/40 | | | X |
| 23/45 | | | |

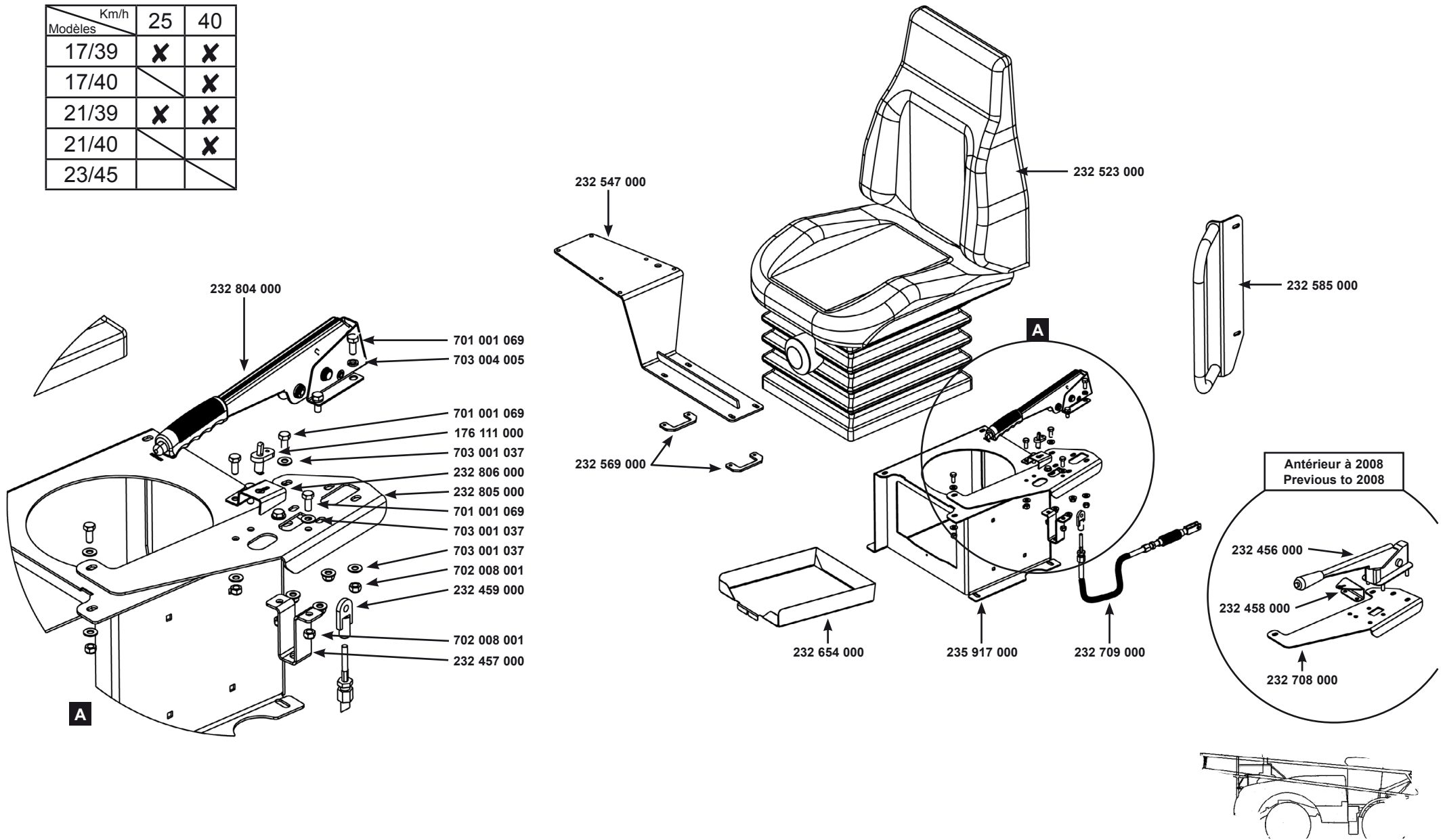

| Modèles \ Km/h | 25 | 40 |
|----------------|----|----|
| 17/39 | X | X |
| 17/40 | | X |
| 21/39 | X | X |
| 21/40 | | X |
| 23/45 | X | |

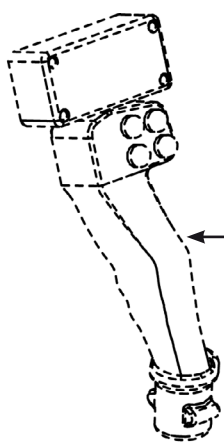

**Poignée
d'avancement
Complete joystick**

**Chapitre 8
Planche D01**

- Rep 1 Réf 701 010 004
- Rep 2 Réf 702 008 021
- Rep 3 Réf 701 001 028
- Rep 4 Réf 234 441 000
- Rep 5 Réf 701 010 004
- Rep 6 Réf 091 272 000
- Rep 7 Réf 706 630 020
- Rep 8 Réf 701 005 004
- Rep 9 Réf 702 008 021
- Rep 10 Réf 234 481 000

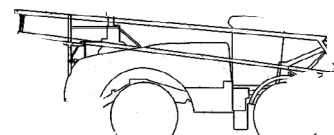
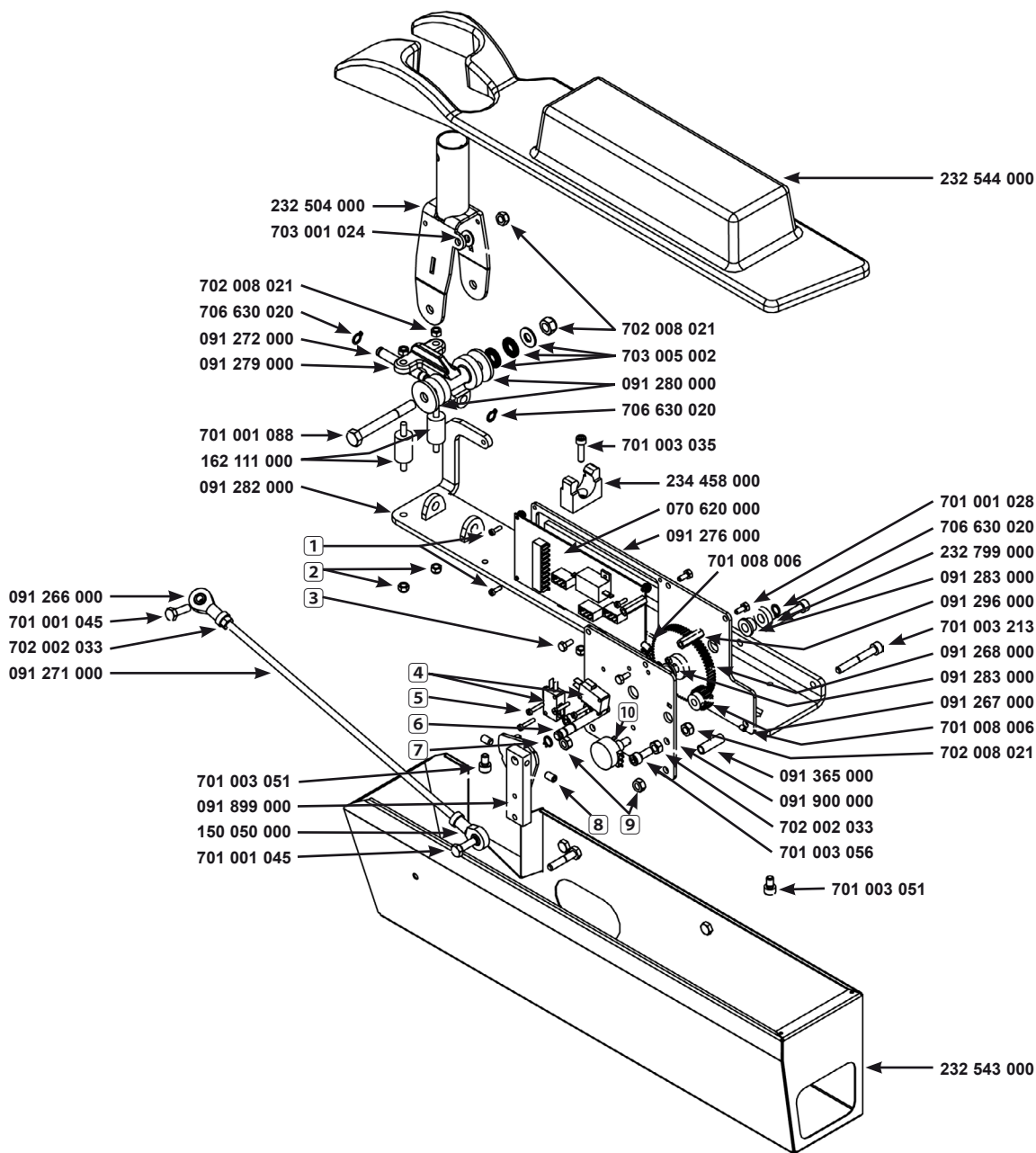

| Km/h | 25 | 40 |
|-------|----|----|
| 17/39 | X | X |
| 17/40 | | X |
| 21/39 | X | X |
| 21/40 | | X |
| 23/45 | | |

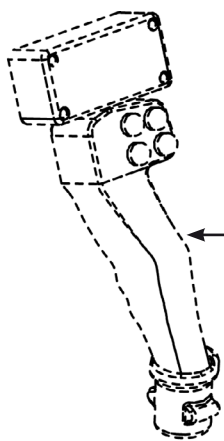

**Poignée
d'avancement
Complete joystick**

**Chapitre 8
Planche D01**

- Rep 1 Réf 701 010 004
- Rep 2 Réf 702 008 021
- Rep 3 Réf 701 001 028
- Rep 4 Réf 240 825 000
- Rep 5 Réf 234 509 000
- Rep 6 Réf 234 441 000
- Rep 7 Réf 701 010 004
- Rep 8 Réf 091 272 000
- Rep 9 Réf 706 630 020
- Rep 10 Réf 701 005 004
- Rep 11 Réf 702 008 021
- Rep 12 Réf 240 853 000

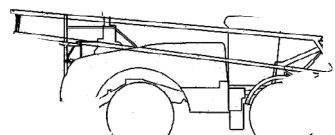
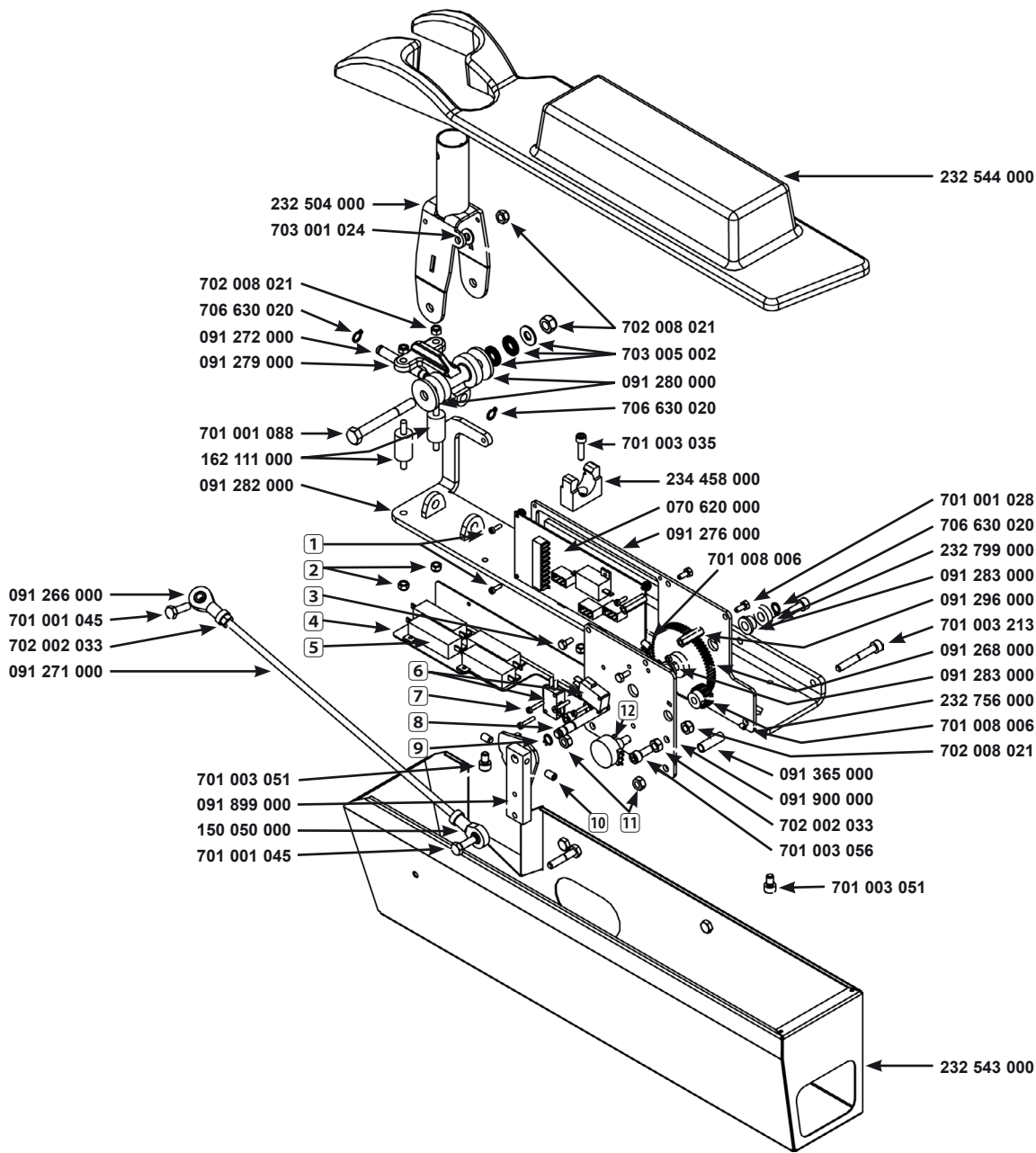

| Km/h | 25 | 40 |
|-------|----|----|
| 17/39 | X | X |
| 17/40 | | X |
| 21/39 | X | X |
| 21/40 | | X |
| 23/45 | X | |

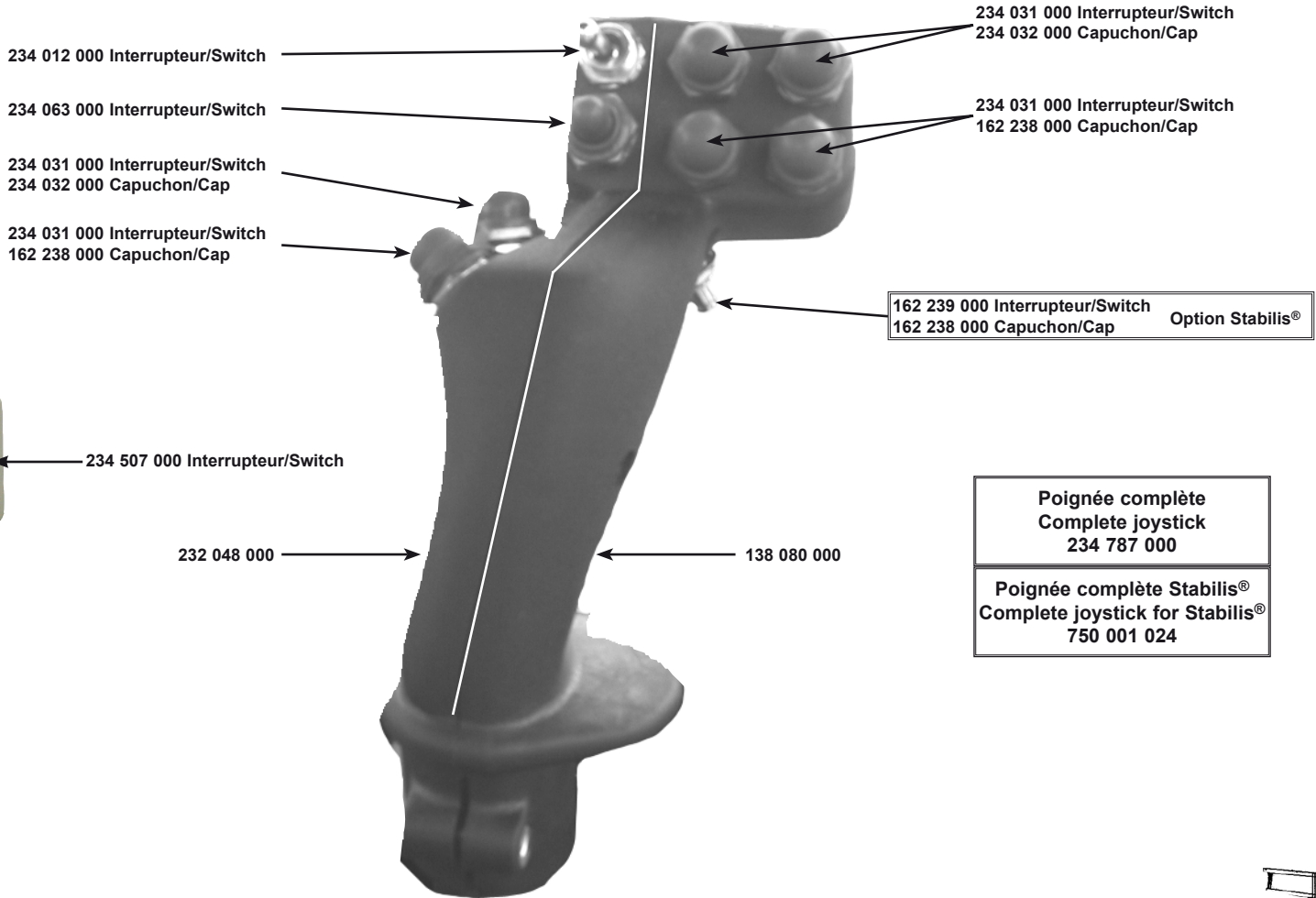

| |
|---|
| <p>Poignée complète Complete joystick 234 787 000</p> |
| <p>Poignée complète Stabilis® Complete joystick for Stabilis® 750 001 024</p> |

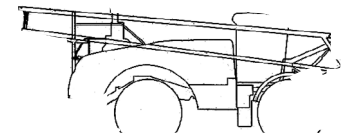

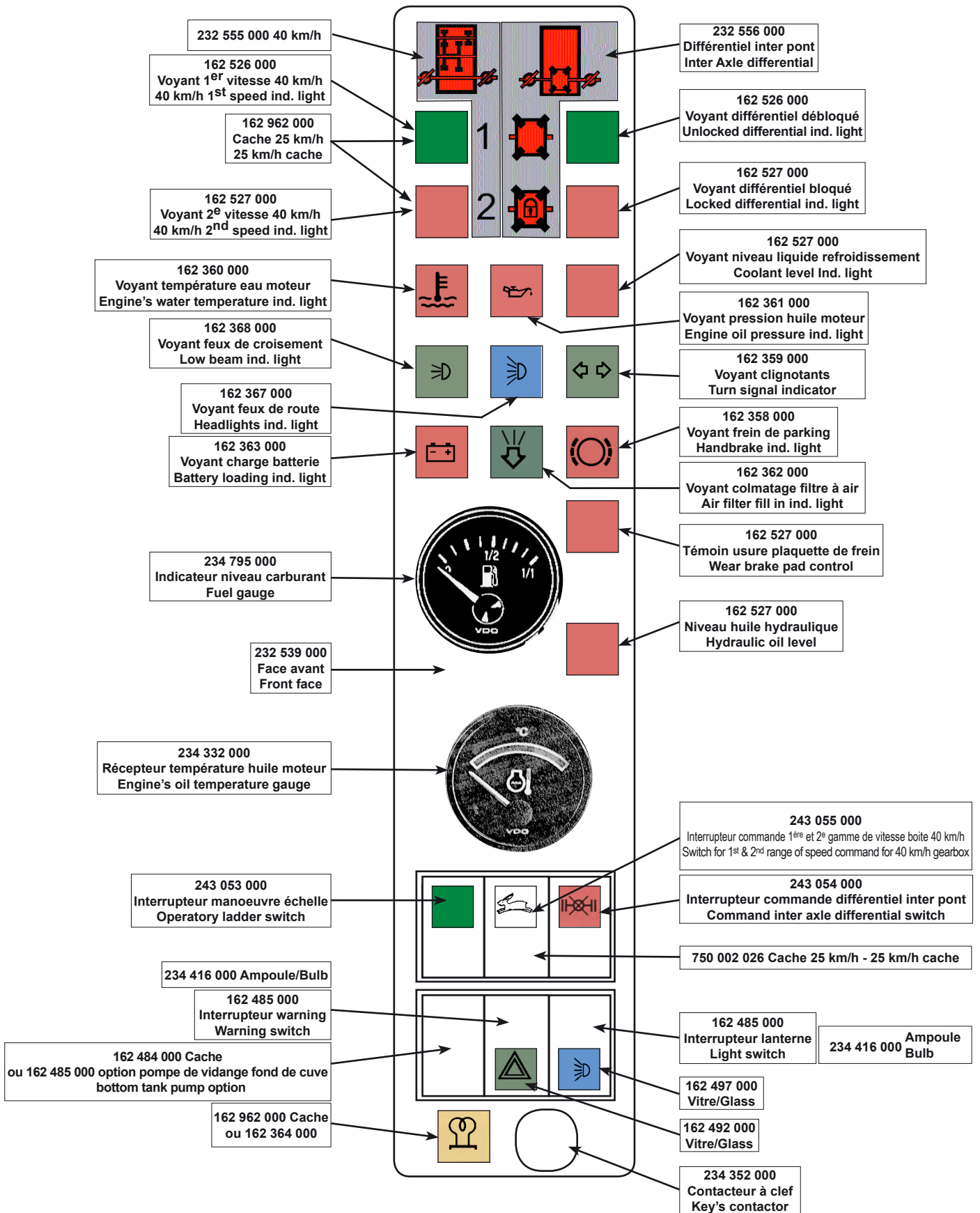

FACE AV ÉQUIPÉE 25 KM/H 232 557 000
COMPLETE FRONT SIDE
FACE AV ÉQUIPÉE 40 KM/H 232 540 000

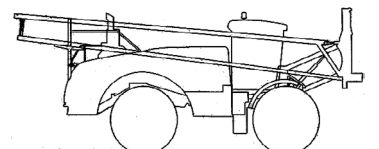

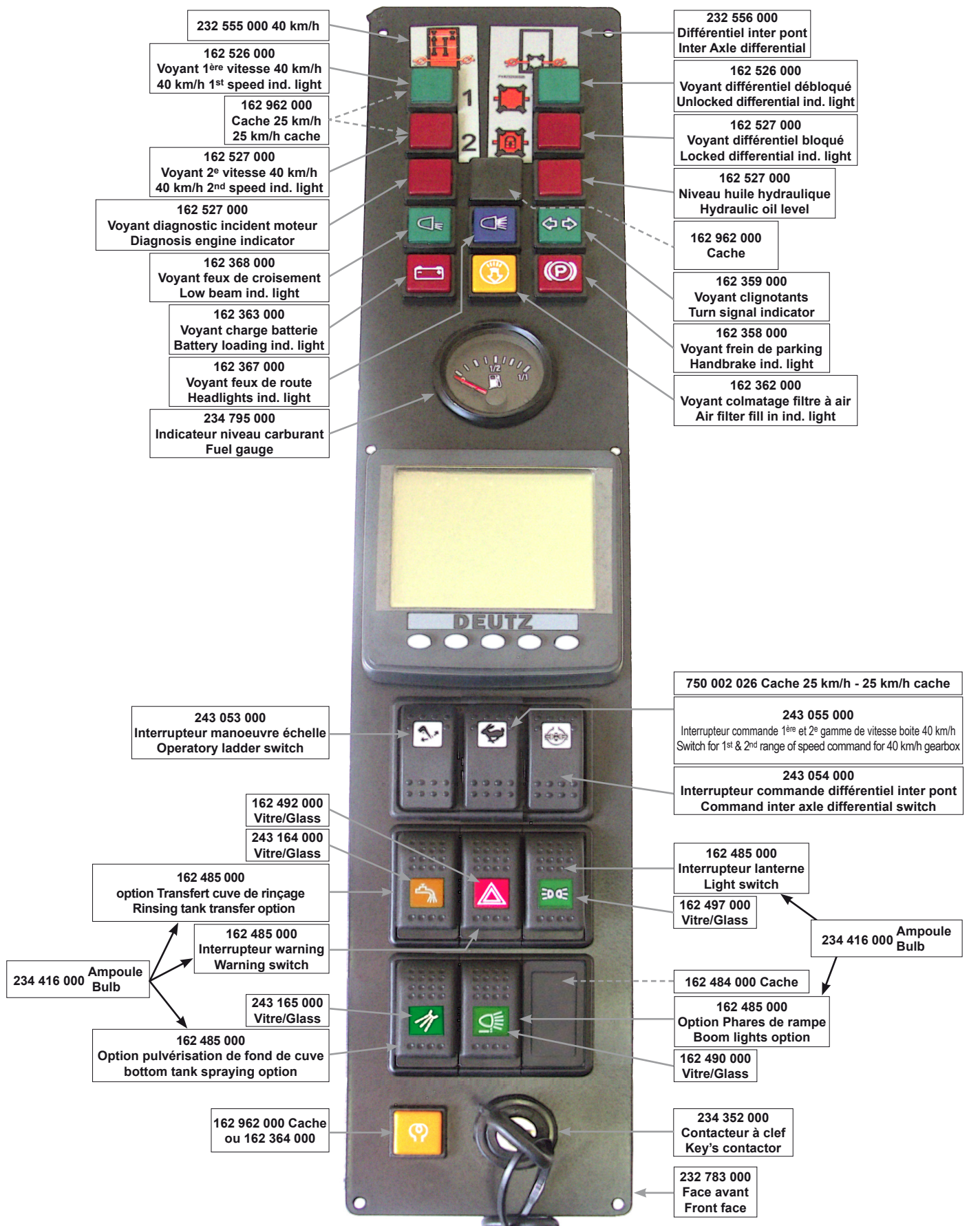

FACE AV ÉQUIPÉE 25 KM/H 232 751 000
 COMPLETE FRONT SIDE
 FACE AV ÉQUIPÉE 40 KM/H 232 752 000

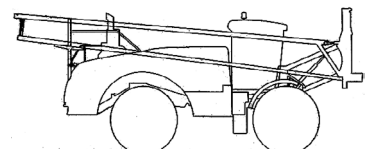

| Km/h Modèles | 25 | 40 |
|-----------------|----|----|
| 17/39 | X | X |
| 21/39 | X | X |
| 23/45 | X | |

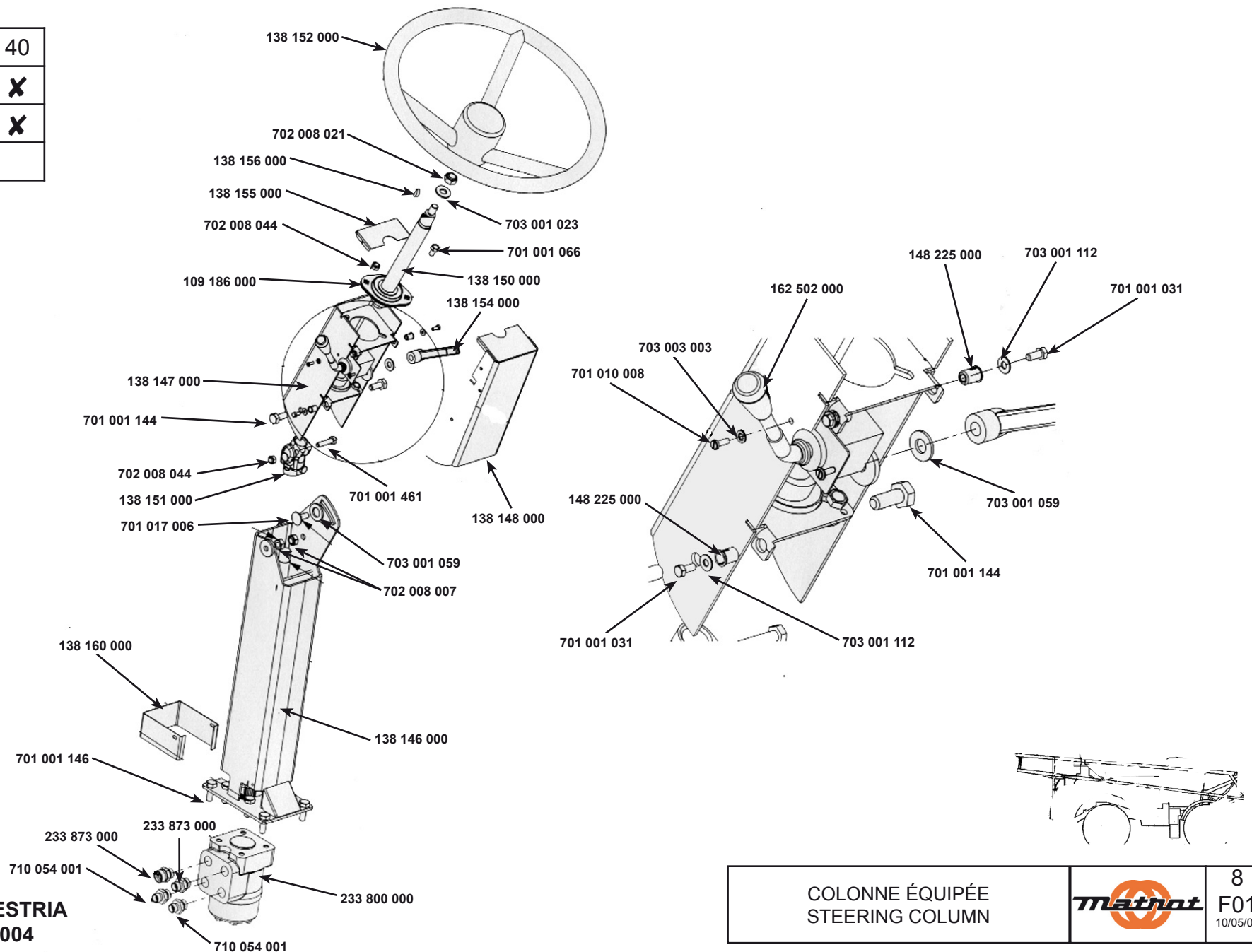

CATALOGUE MAESTRIA
RAMPE AV 2004

| | | |
|------------------------------------|---|----------------------|
| COLONNE ÉQUIPÉE STEERING COLUMN |  | 8 F01 10/05/05 |
|------------------------------------|---|----------------------|

| Modèles \ Km/h | 25 | 40 |
|----------------|----|----|
| 17/39 | X | X |
| 21/39 | X | X |
| 23/45 | X | |

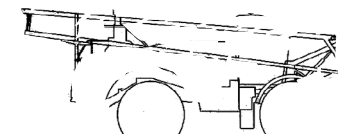
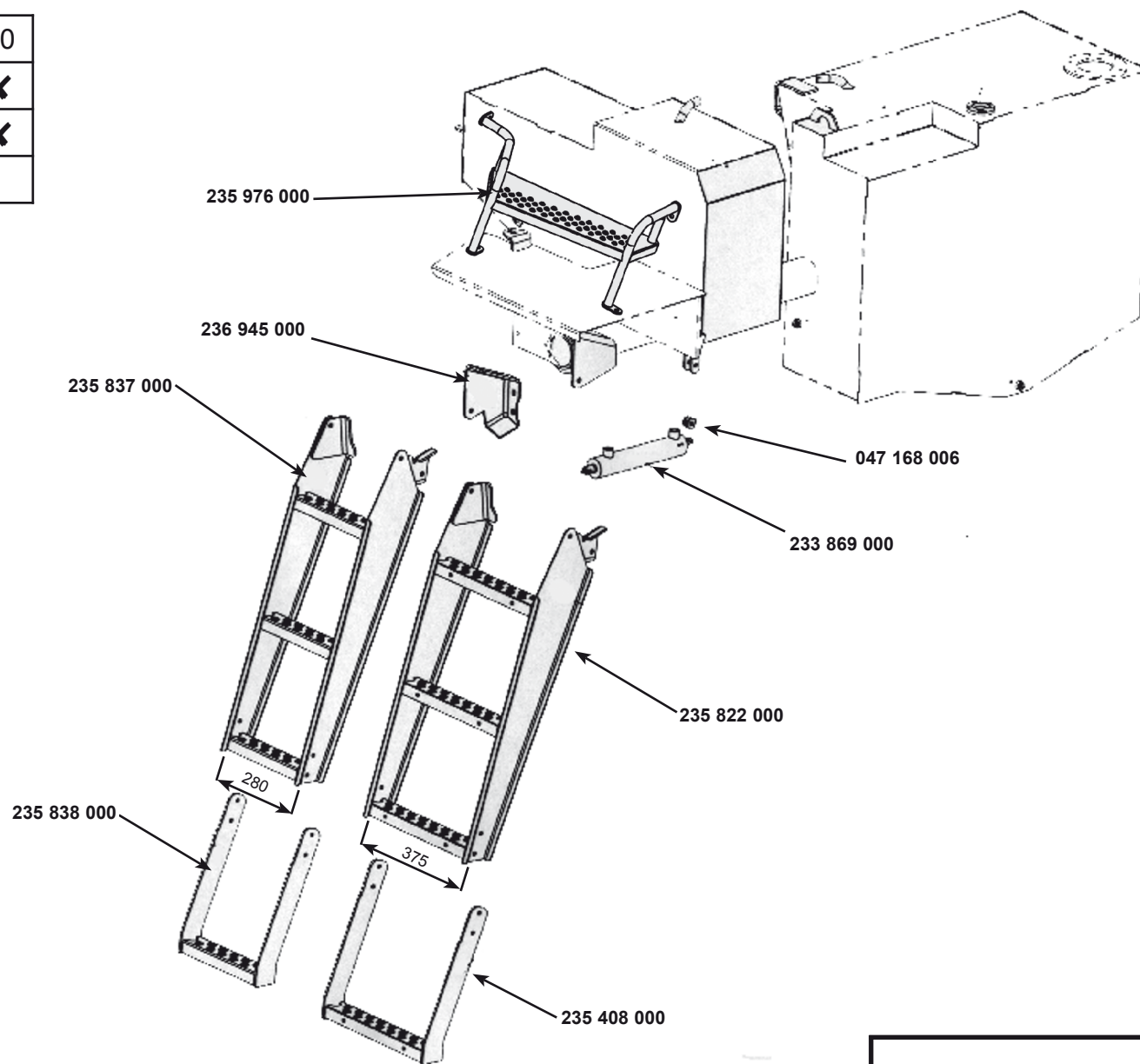

**CATALOGUE MAESTRIA
RAMPE AV 2004**

Correctif 23 mai 2006/May 23th '06 correction

ECHELLE AVANT 1 m/1,30 m
FRONT LADDER



8
G01
30/05/05

| Km/h | 25 | 40 |
|-------|----|----|
| 17/39 | X | |
| 21/39 | X | |
| 23/45 | | |

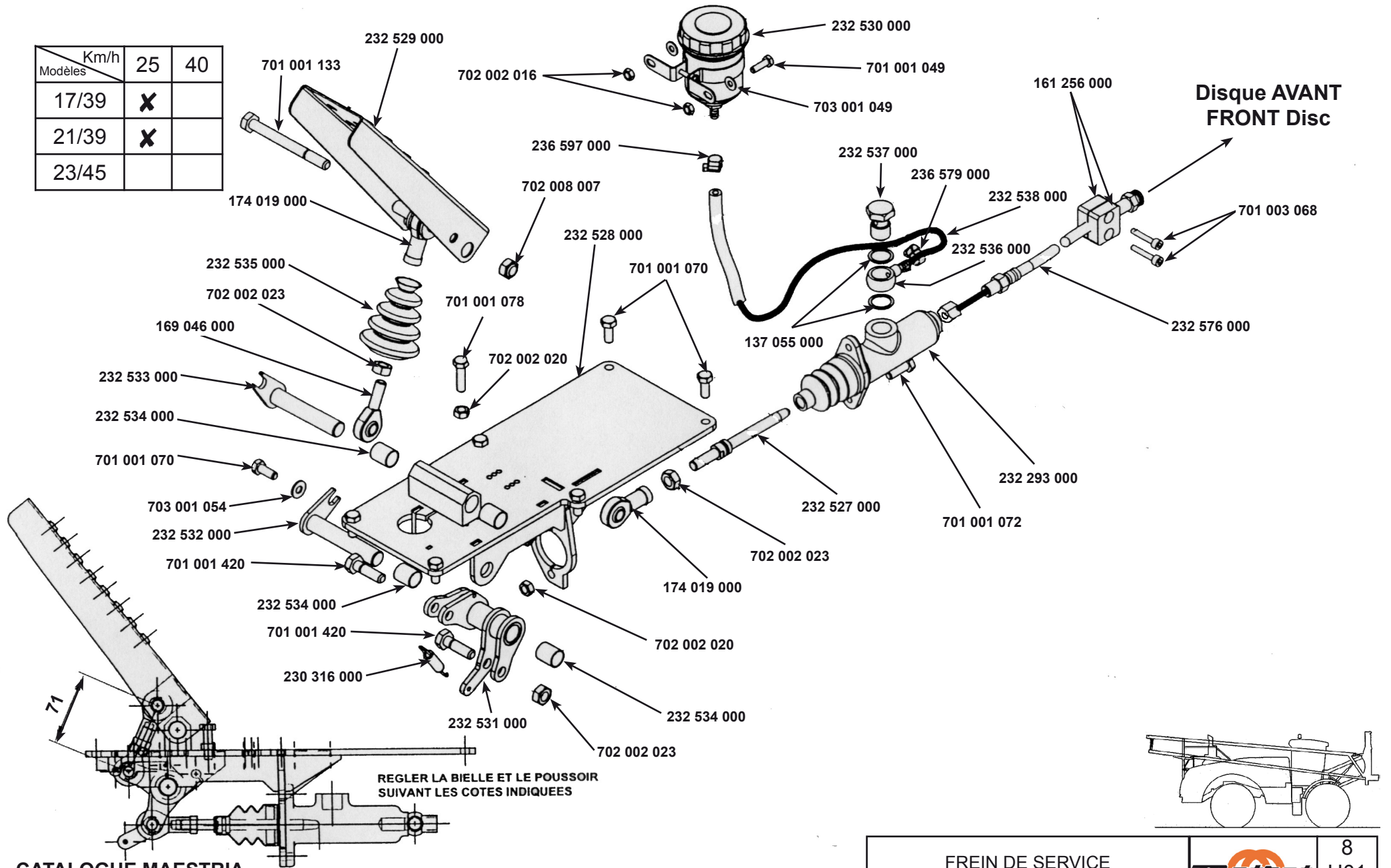

CATALOGUE MAESTRIA
RAMPE AV 2004

FREIN DE SERVICE
BRAKES



8
H01
18/11/04

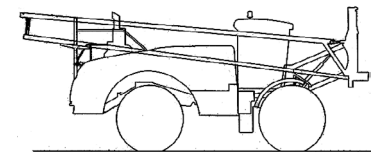

| Km/h | 25 | 40 |
|-------|----|----|
| 17/39 | | X |
| 21/39 | | X |
| 23/45 | X | |

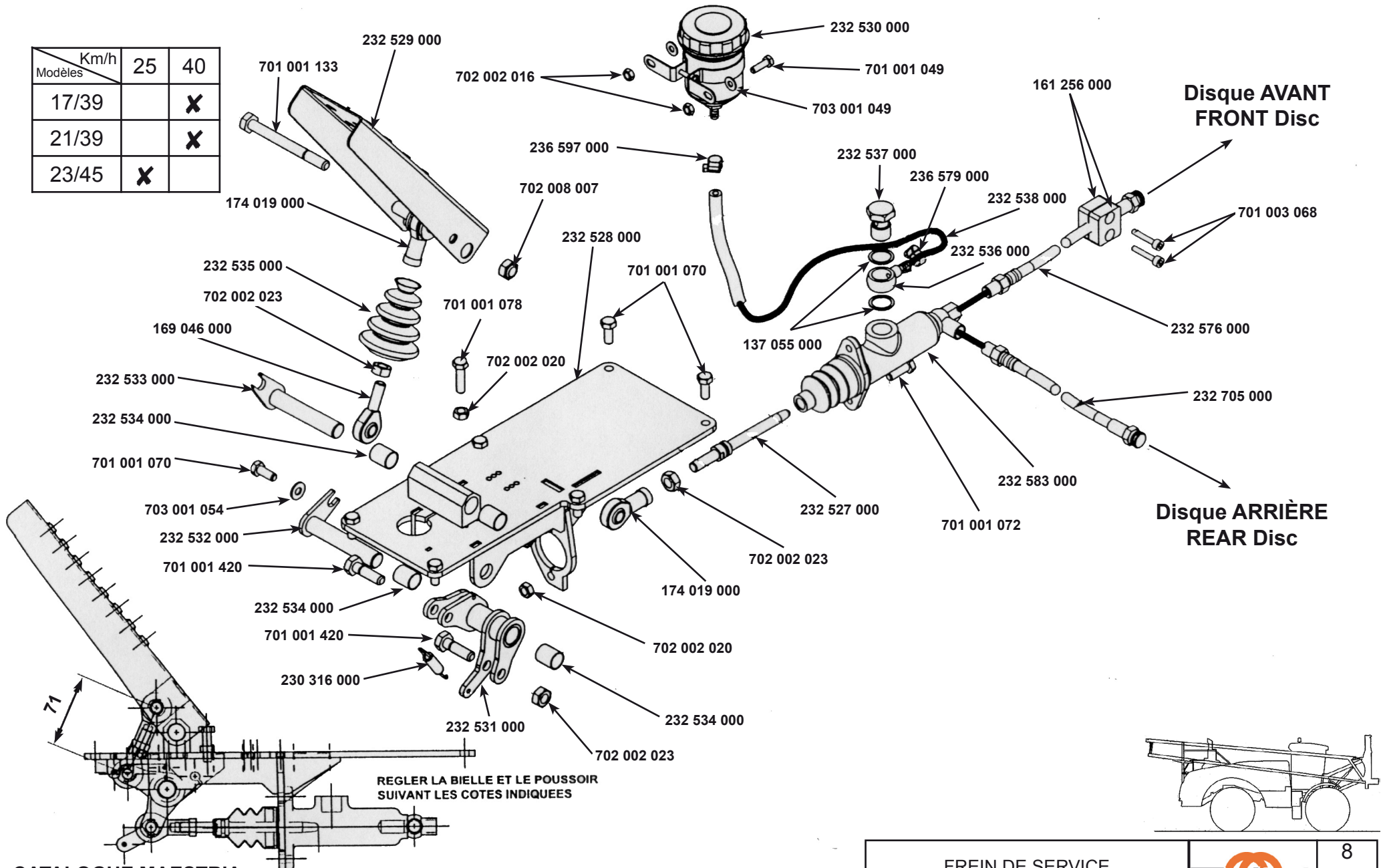

CATALOGUE MAESTRIA
RAMPE AV 2004

REGLER LA BIELLE ET LE POUSSOIR
SUIVANT LES COTES INDIQUEES

| | | |
|----------------------------|---|----------------------|
| FREIN DE SERVICE BRAKES |  | 8 H02 18/11/04 |
|----------------------------|---|----------------------|

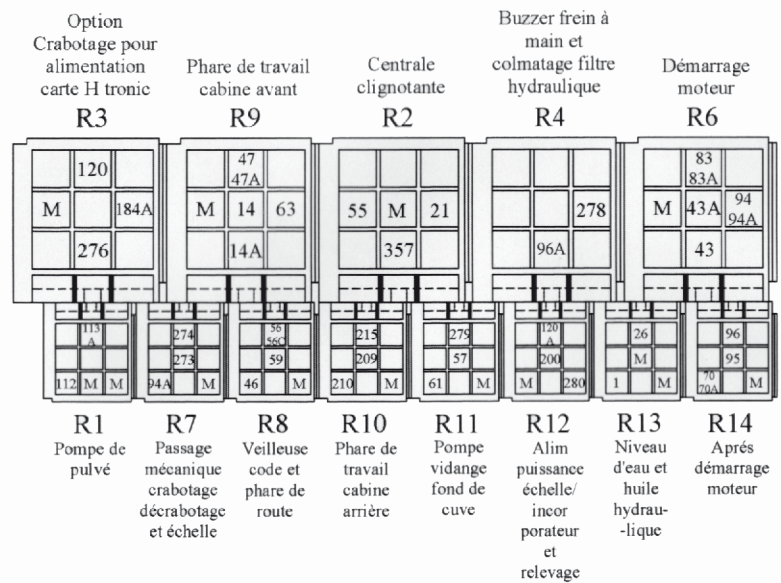

Relais Ref 234 295 000
position R3-R6-R9

Relais Ref 234 074 000
position R2

Relais Ref 234 075 000
position R4

Relais Ref 243 031 000
position R1

Relais Ref 243 030 000
position R7-R8-R10 à R14

| | | | | | | | | |
|---|--|---|--|---|--|--|---|--|
| F4 Alimentation klaxon 30 10A 44 | F8 Alimentation avant contact 30 3A 118 Boîtier Tejet | F12 30 | F16 30 | F20 Alimentation veilleuse droite 59 5A 23 | F24 Alimentation relais R6 142 25A 83 démarrage moteur | F28 Diode carte d'avancement 35 3A 82 | F32 Alimentation capteur toit & buzzer de recul 35 5A 58 | F36 Alimentation relais temporisé préchauffage 35 10A 92 |
| F1 | F5 | F9 | F13 | F17 | F21 | F25 | F29 | F33 |
| F1 Alimentation Générale avant contact 30 30A 54A | F5 Alimentation relais R3 30 20A 64 moteur essuie glace | F9 Alimentation plafonnier et autoradio 30 3A 214 | F13 Alimentation relais R11 vidange fond de cuve 30 15A 57 | F17 Alimentation bouton code / feux de route 59 15A 36 | F21 Alimentation relais R7 97 10A 71 Bouton changement de vitesse hydraulique | F25 Arrêt moteur 35 10A 79 | F29 Carte LK7076 35 10A 119B Pompe pulvé & vanne fin de cuve | F33 Alimentation ventilation cabine 35 15A 48 |
| F1 Alimentation Générale avant contact 30 30A 54 | F5 Alimentation relais R8 30 20A 56C Veilleuse, code, phare | F9 Alimentation relais R9 30 20A 47 Phares de travail cabine avant | F13 Alimentation calculateur Stabils 96A 15A 289 | F17 Alimentation relais R10 30D 15A 209 Phares de travail cabine arrière | F21 Alim carte de direction 144 5A 78 78A | F25 Alim voyants, sonde niveau hydraulique/eau 35 3A 67 galvanomètre T° eau et jauge à gasoil | F29 Carte LK7076 35 15A 109 Vannes de tronçons | F33 Alimentation accélérateur électrique 35 5A 195 |

- Fusible 3A Réf 162 501 000
- Fusible 5A Réf 162 306 000
- Fusible 10A Réf 162 308 000
- Fusible 15A Réf 162 309 000
- Fusible 20A Réf 162 310 000
- Fusible 25A Réf 162 311 000
- Fusible 30A Réf 162 312 000

750001023

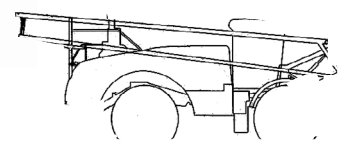

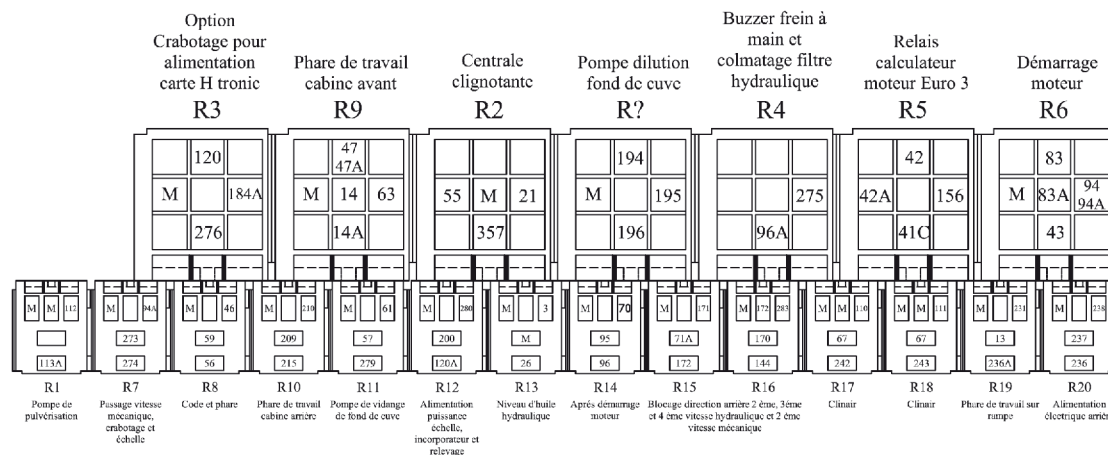

Relais Ref 243 031 000
position R1-R16-R17-R18

Relais Ref 234 963 000
position R2

Relais Ref 234 295 000
position R3-R6-R9

Relais Ref 234 075 000
position R4

Relais Ref 243 058 000
position R5

Relais Ref 243 030 000
position R7-R8-R10 à R15-R19-R20

| | | | | | | | | |
|---|--|--|---|---|--|--|--|--|
| F4 Alimentation klaxon 30 10A 44 | F8 Alimentation avant contact boîtier Teejet 30 3A 118 | F12 Alimentation relais R3 pompe dilution 30 30A 196 | F16 Alimentation micro relais R10 phare de travail arrière de la cabine 30 15A 209 | F20 Alimentation veilleuse droite 178 5A 23 | F24 Alimentation relais R6 démarrage moteur 142 25A 83 | F28 Alimentation carte de direction 144 5A 78 144A 78A | F32 35 | F36 Alimentation afficheur Deutz 35 3A 177 |
| F1 Alimentation générale avant contact 30 30A 54A | F5 Alimentation micro relais R8 code & phare 30 20A 56 56A | F9 Alimentation relais R9 phare de travail 30 20A 47 | F13 Alimentation micro relais R19 & R20 phare de travail sur rampe et allim électrique arrière 30 20A 236 236A | F17 Alimentation avant coupe batterie 1 15A 42 42A | F21 Alimentation régulée par convertisseur 97 3A 82 | F25 Alimentation voyant, sonde hydraulique, boutons, jauge à gazon 35 3A 67 | F29 Alimentation des boutons dépli/repli de la rampe sur la carte LK7089 35 10A 119B | F33 Alimentation calculateur Stablis 96 15A 289 96A |
| F12 Alimentation centrale clignotante 30 10A 21 | F16 Alimentation micro relais R11 pompe vidange fond de cuve 30 15A 57 | F20 Alimentation veilleuse gauche 178 5A 62 | F24 Alimentation bobine micro relais R14 alternateur après démarrage moteur 34 3A 70 | F28 Alimentation micro relais R14 35 20A 95 | F32 Alimentation des boutons dépli/repli de la rampe 35 10A 276 | F36 Alimentation micro relais R7 vitesse mécanique crabotage et échelle 35 15A 274 | | |
| F4 Alimentation générale avant contact 30 30A 54A | F8 Alimentation micro relais R8 code & phare 30 20A 56 56A | F12 Alimentation centrale clignotante 30 10A 21 | F16 Alimentation micro relais R11 pompe vidange fond de cuve 30 15A 57 | F20 Alimentation veilleuse gauche 178 5A 62 | F24 Alimentation bobine micro relais R14 alternateur après démarrage moteur 34 3A 70 | F28 Alimentation micro relais R14 35 20A 95 | F32 Alimentation des boutons dépli/repli de la rampe sur la carte LK7089 35 10A 119B | F36 Alimentation micro relais R7 vitesse mécanique crabotage et échelle 35 15A 274 |

232 791 000

Fusible 3A Réf 162 501 000
Fusible 5A Réf 162 306 000
Fusible 7,5A Réf 162 307 000
Fusible 10A Réf 162 308 000
Fusible 15A Réf 162 309 000
Fusible 20A Réf 162 310 000
Fusible 25A Réf 162 311 000
Fusible 30A Réf 162 312 000

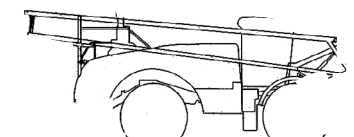

| Modèles \ Km/h | 25 | 40 |
|----------------|----|----|
| 17/39 | X | X |
| 17/40 | | X |
| 21/39 | X | X |
| 21/40 | | X |
| 23/45 | X | |

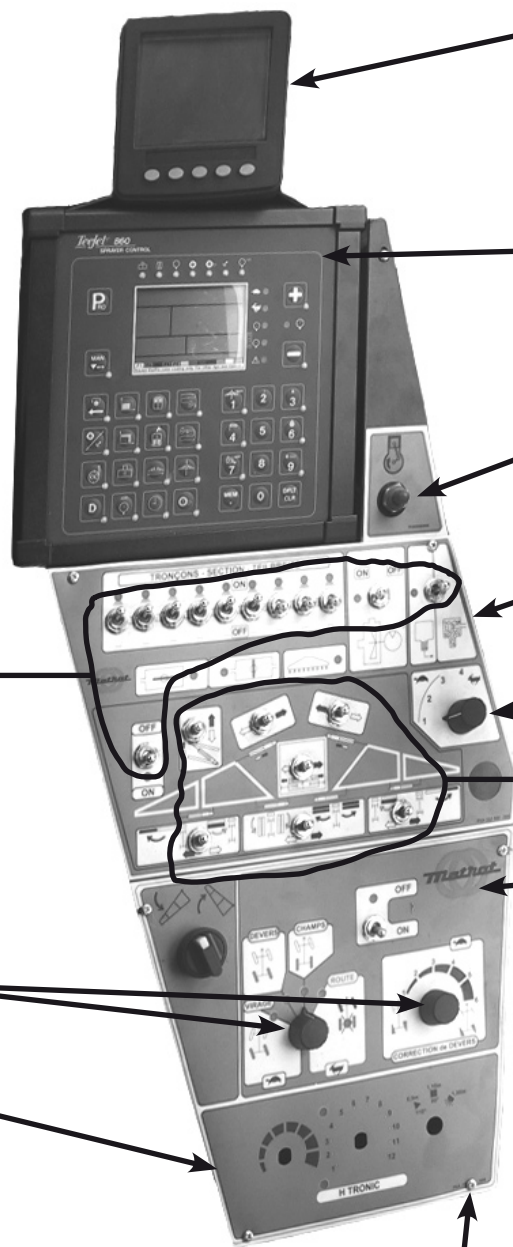

Option Stabilis®
(Sauf 23/45 - Except 23/45)
Afficheur/Screen

Écran/Screen 234 979 000
Support/Bracket 234 989 000

Boîtier/Box 860 Réf. 234 750 000

Bouton accélérateur | Euro II - 234 790 000
Accelerator button

Potentiomètre accélérateur | Euro III - 750 004 021
Accelerator potentiometer

Circuit pupitre rampe
Boom desk circuit
Réf. 007 080 000

234 012 000

Bouton/Button Réf. 008 060 000
Interrupteur/Switch Réf. 008 159 000

234 063 000

Circuit direction arrière
Rear steering circuit
Réf. 007 015 100

008 060 000

H-TRONIC (Option)
Réf. 007 034 000

701 001 027 (x 6)

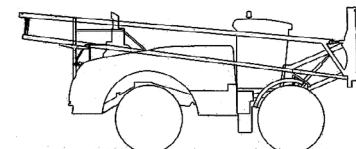

CARTES ÉLECTRONIQUES
ELECTRONIC CARDS



8
J01
04/07/05

CATALOGUE MAESTRIA
RAMPE AV 2004

Correctif mars 2009/March 2009 correction