

Xénon 	Berceau avant / Front cradle	12.10.2010
	246047000	Chap. 01 P. 1

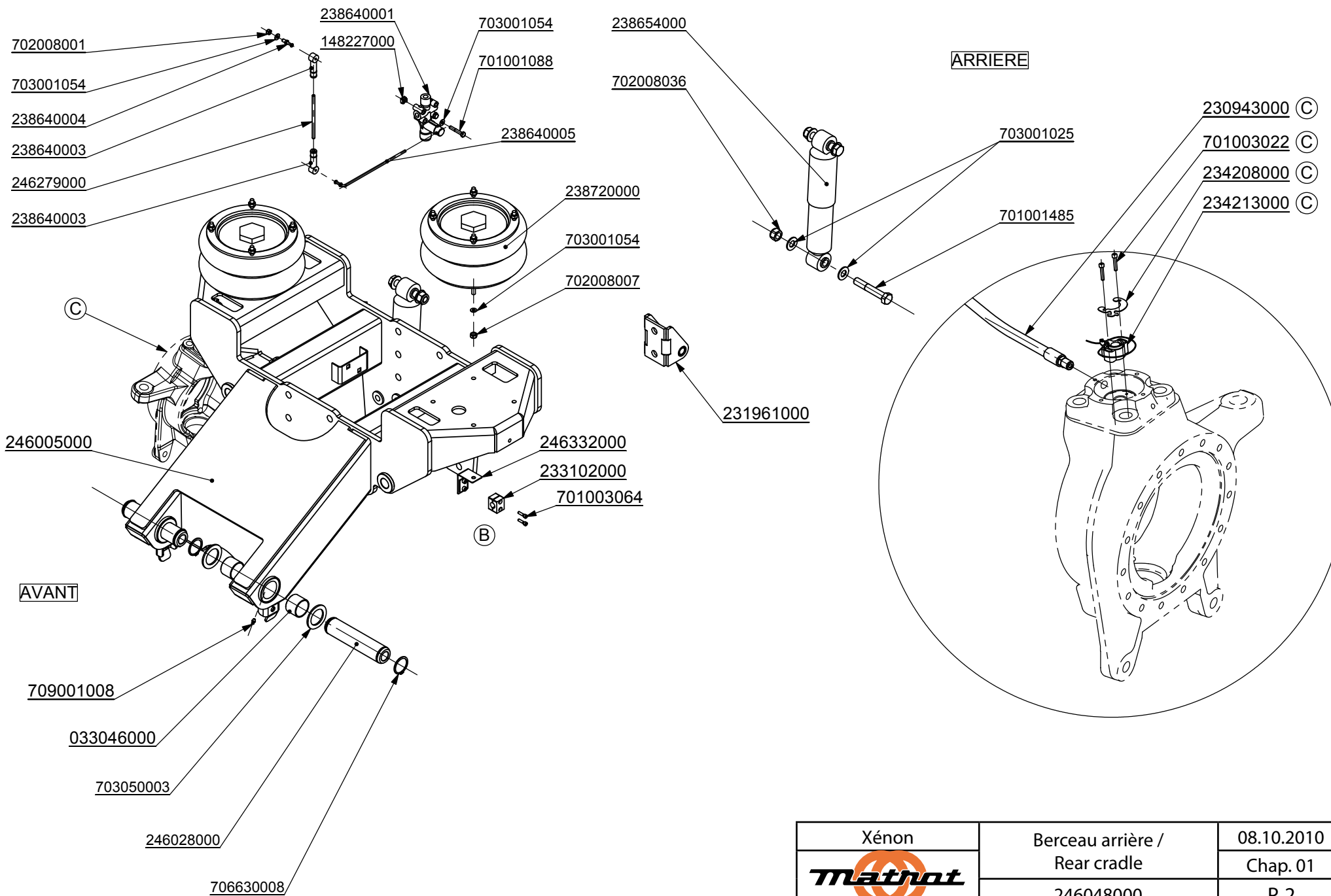

Xénon	Berceau arrière / Rear cradle	08.10.2010
<b>Mathot</b>	246048000	Chap. 01
		P. 2

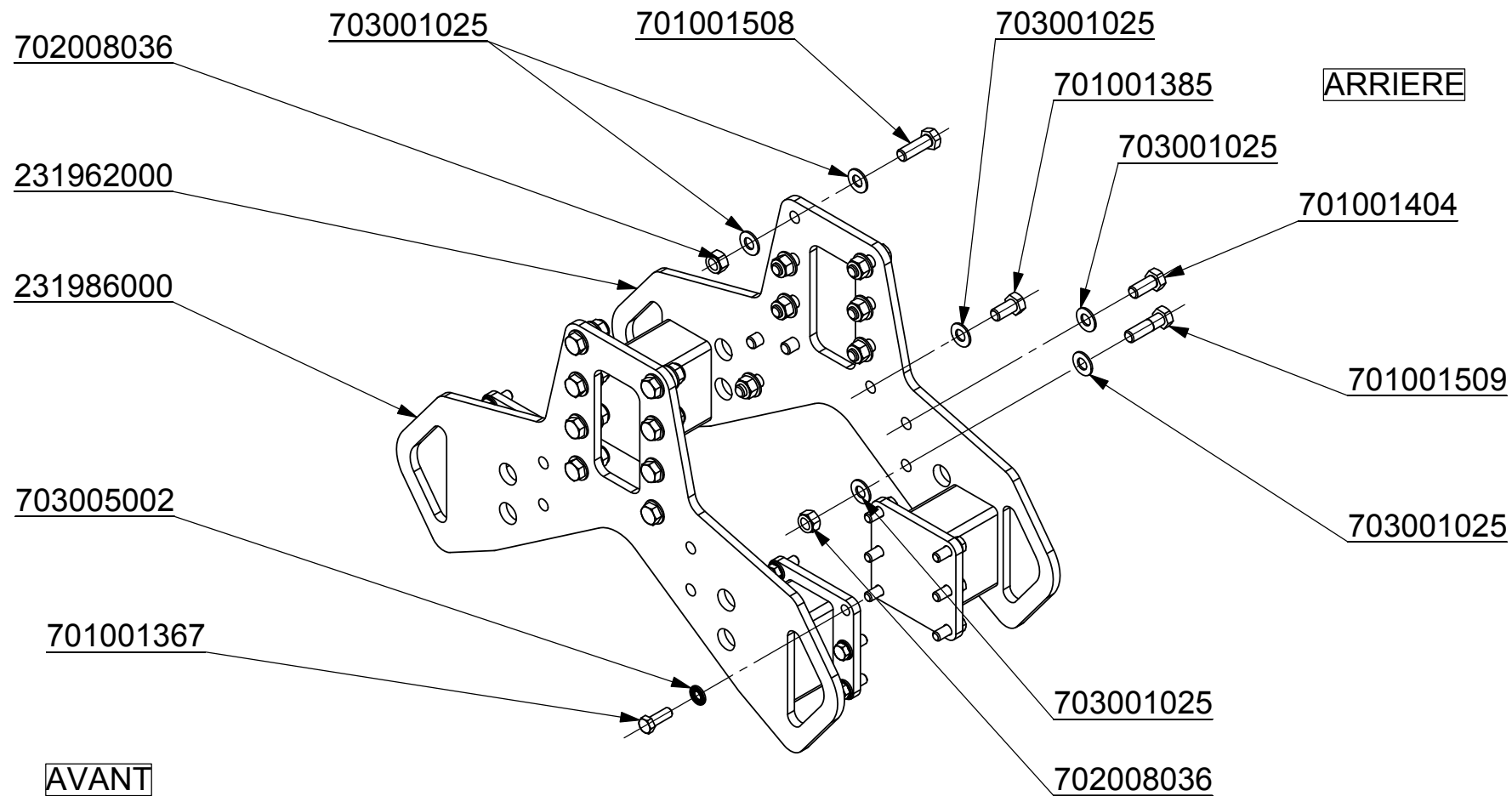

Xénon	Sans Stabilis / Without Stabilis	12.10.2010
<b>Mathot</b>	246300000	Chap. 01
		P. 3

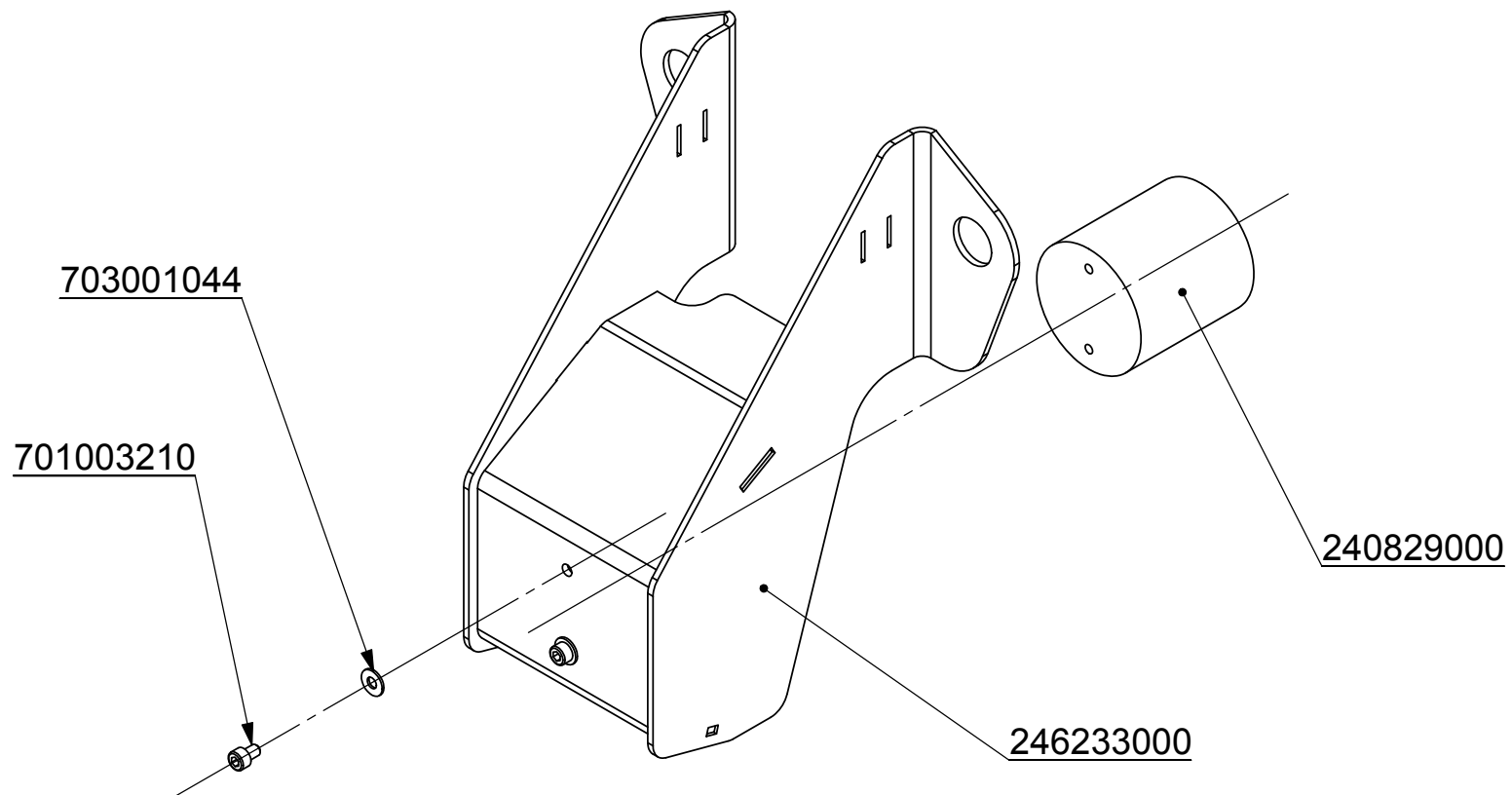

Xénon	Inclinomètre Stabilis/ Stabilis inclinometer	14.10.2010
		Chap. 01
	246301000	P. 4

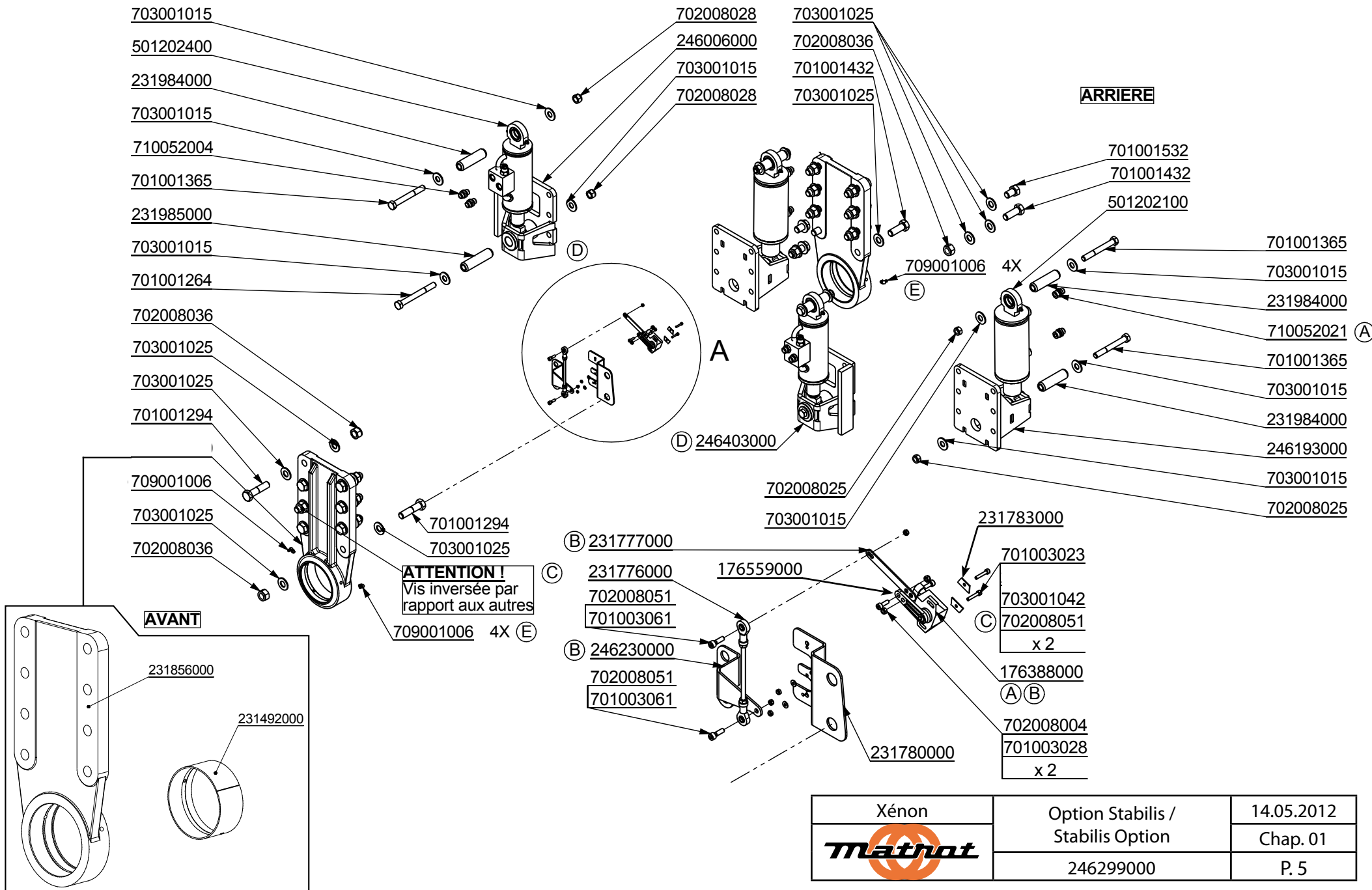

Xénon	Option Stabilis / Stabilis Option	14.05.2012
<b>Mathot</b>	246299000	Chap. 01
		P. 5

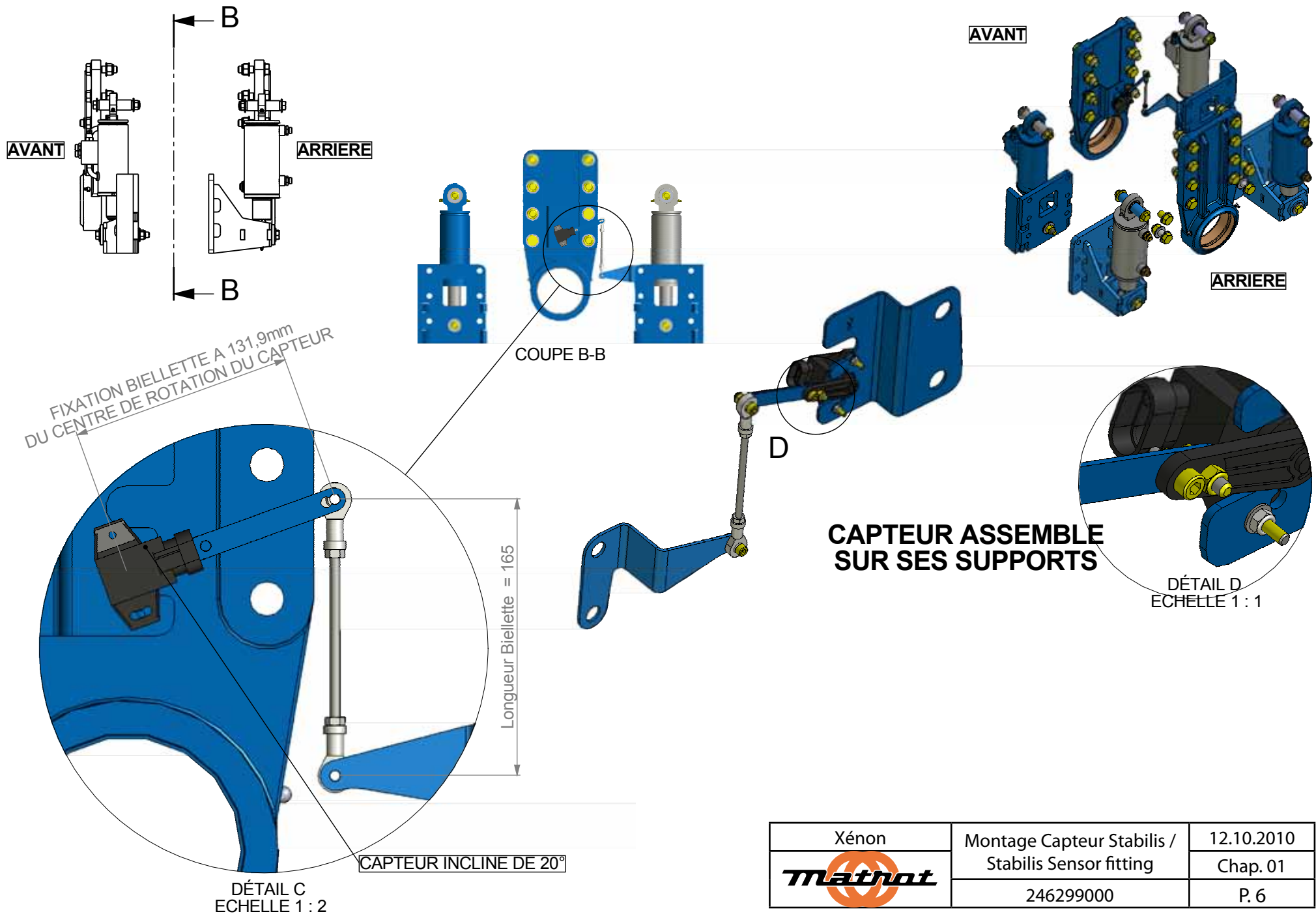

Xénon	Montage Capteur Stabilis / Stabilis Sensor fitting	12.10.2010
<b>Mathot</b>	246299000	Chap. 01
		P. 6

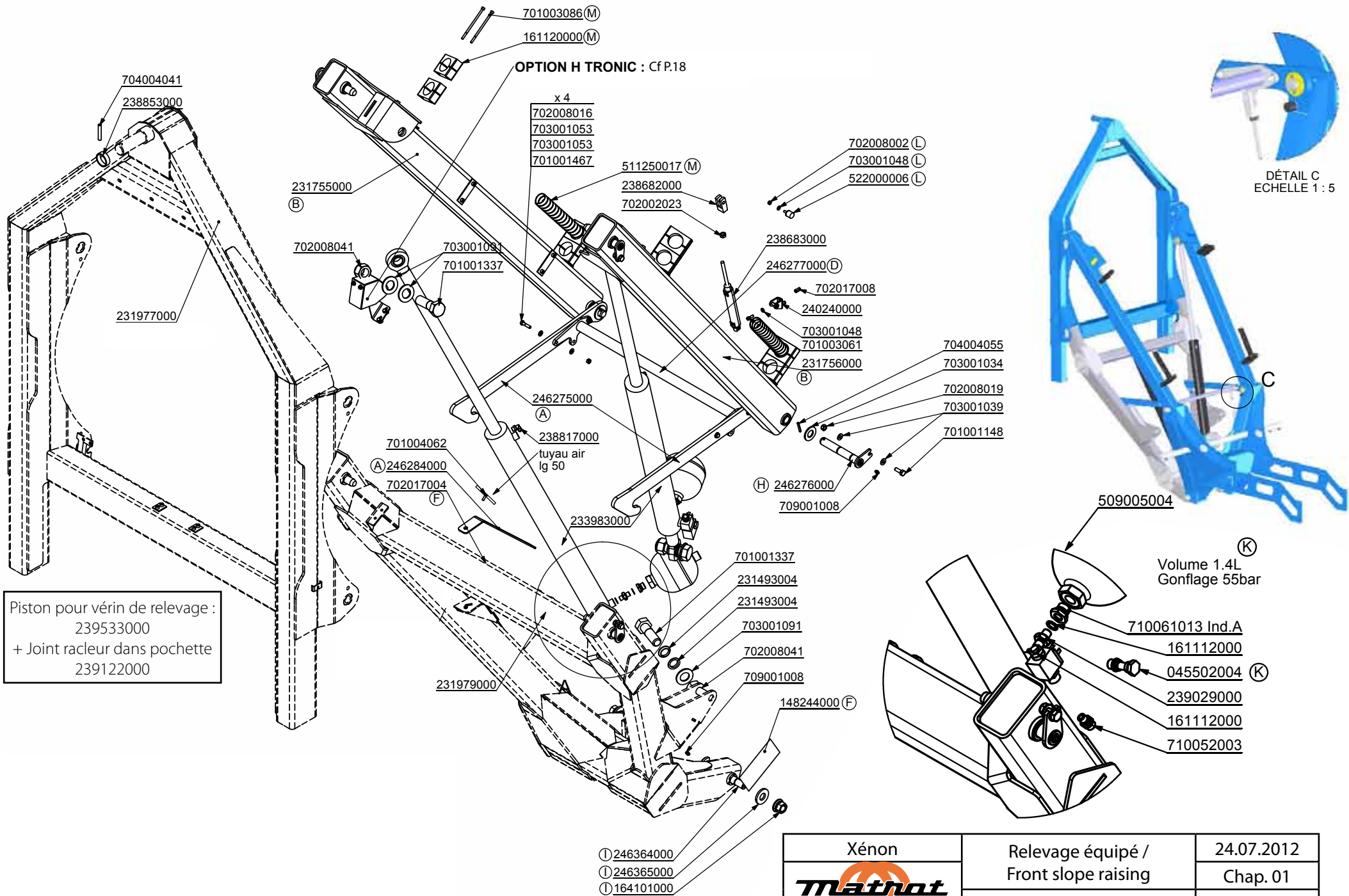

Piston pour vérin de relevage :  
 239533000  
 + Joint racler dans pochette  
 239122000

Xénon 	Relevage équipé / Front slope raising	24.07.2012
	246189000	Chap. 01 P. 7

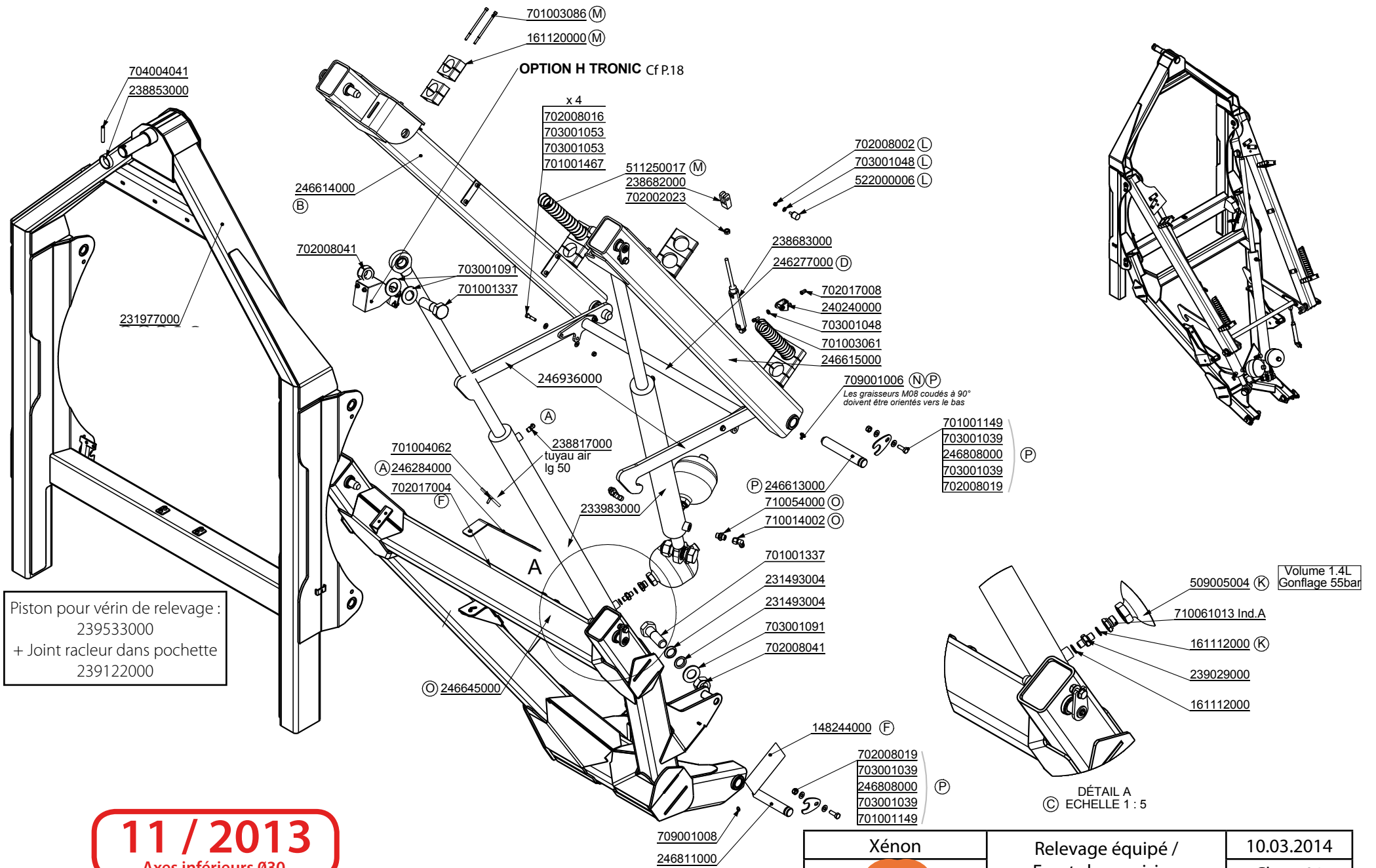

Piston pour vérin de relevage :  
239533000  
+ Joint racleur dans pochette  
239122000

**11 / 2013**  
Axes inférieurs Ø30

Xénon 	Relevage équipé / Front slope raising	10.03.2014
	246189000	Chap. 01 P. 8



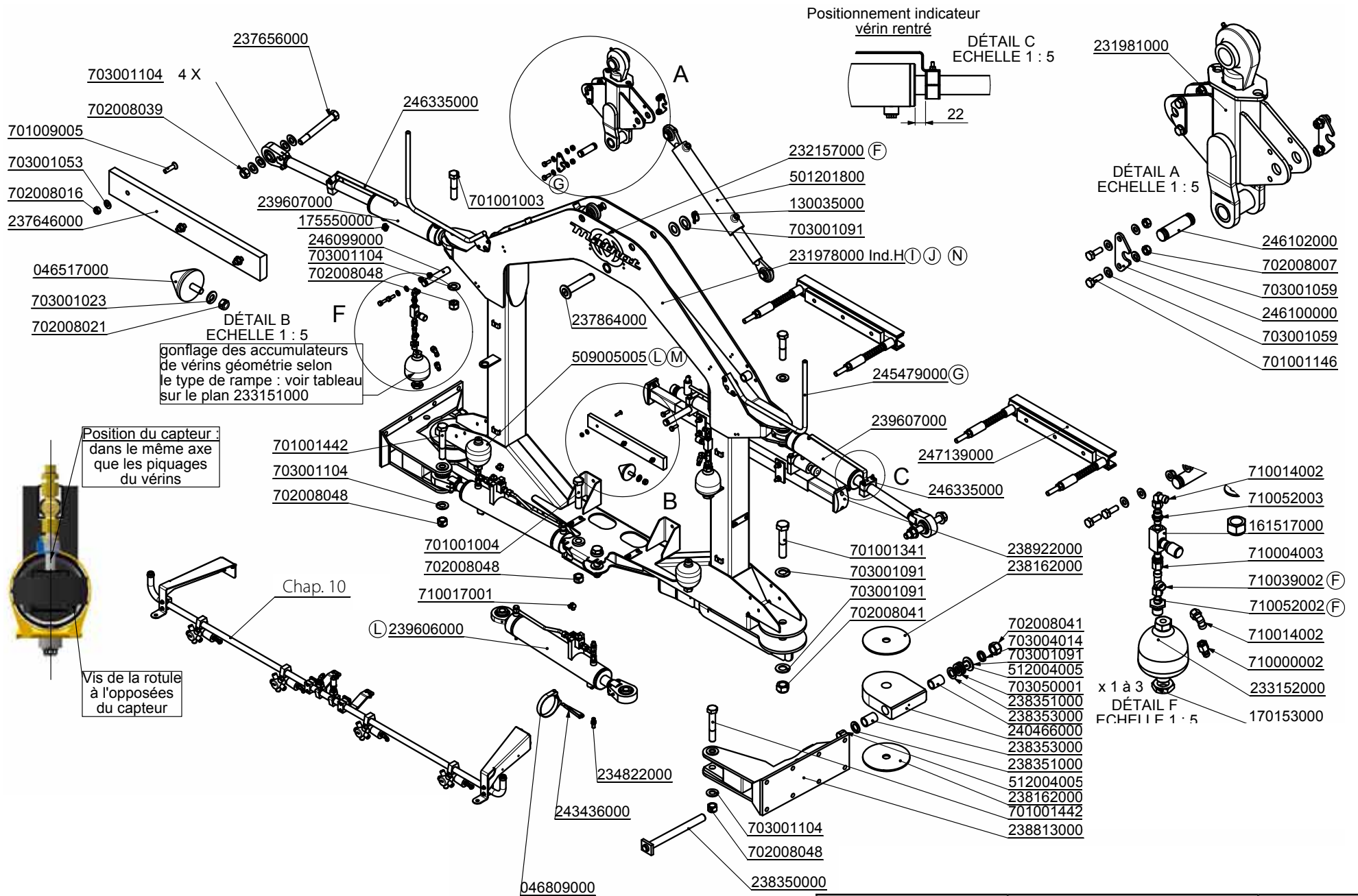

Xénon 	Cadre équipé / Front frame	02.11.2012
	246184000	Chap. 01
		P. 9

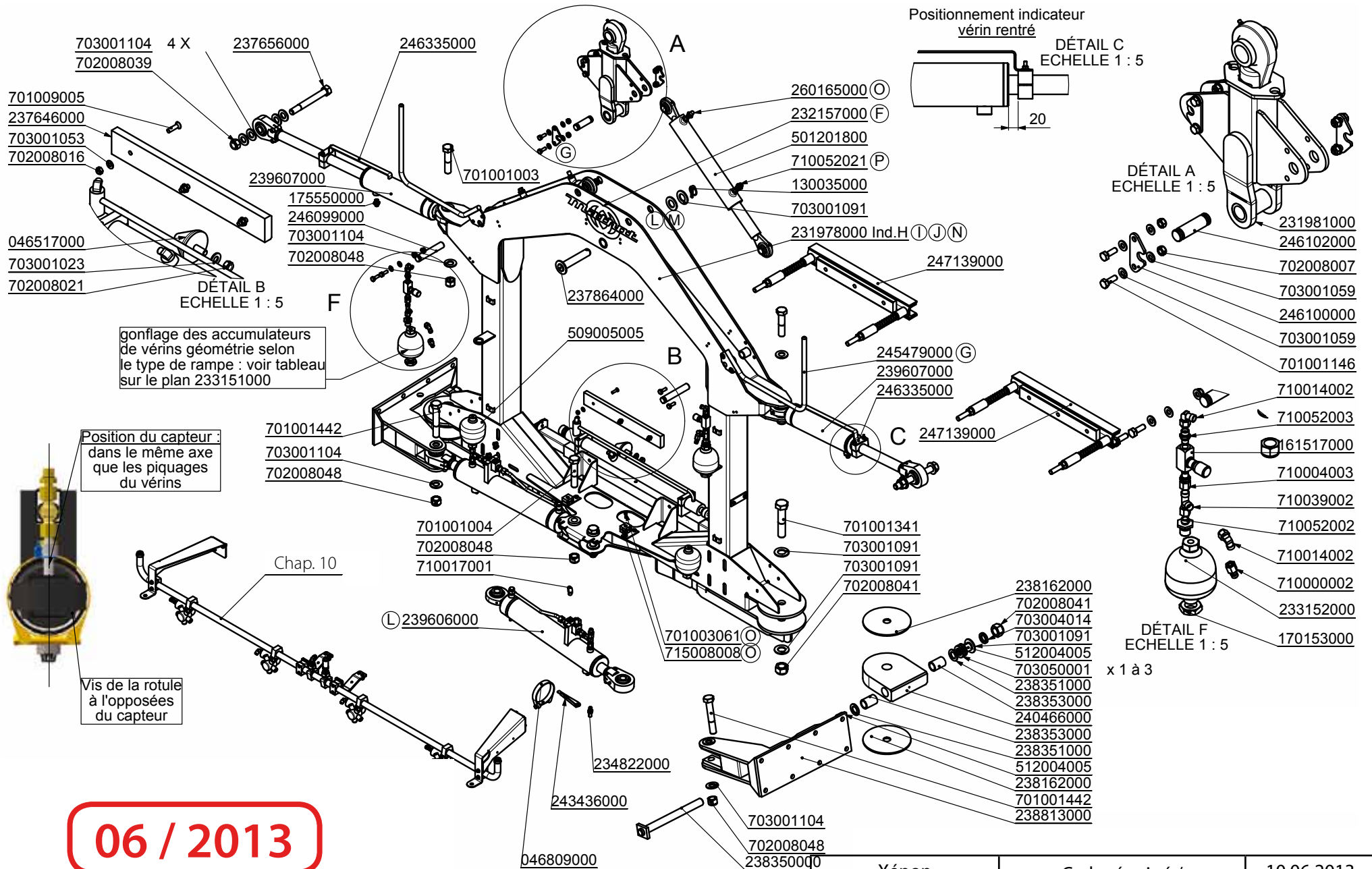

**06 / 2013**

Xénon <b>Mathot</b>	Cadre équipé / Front frame	10.06.2013
	246184000	Chap. 01
		P. 10

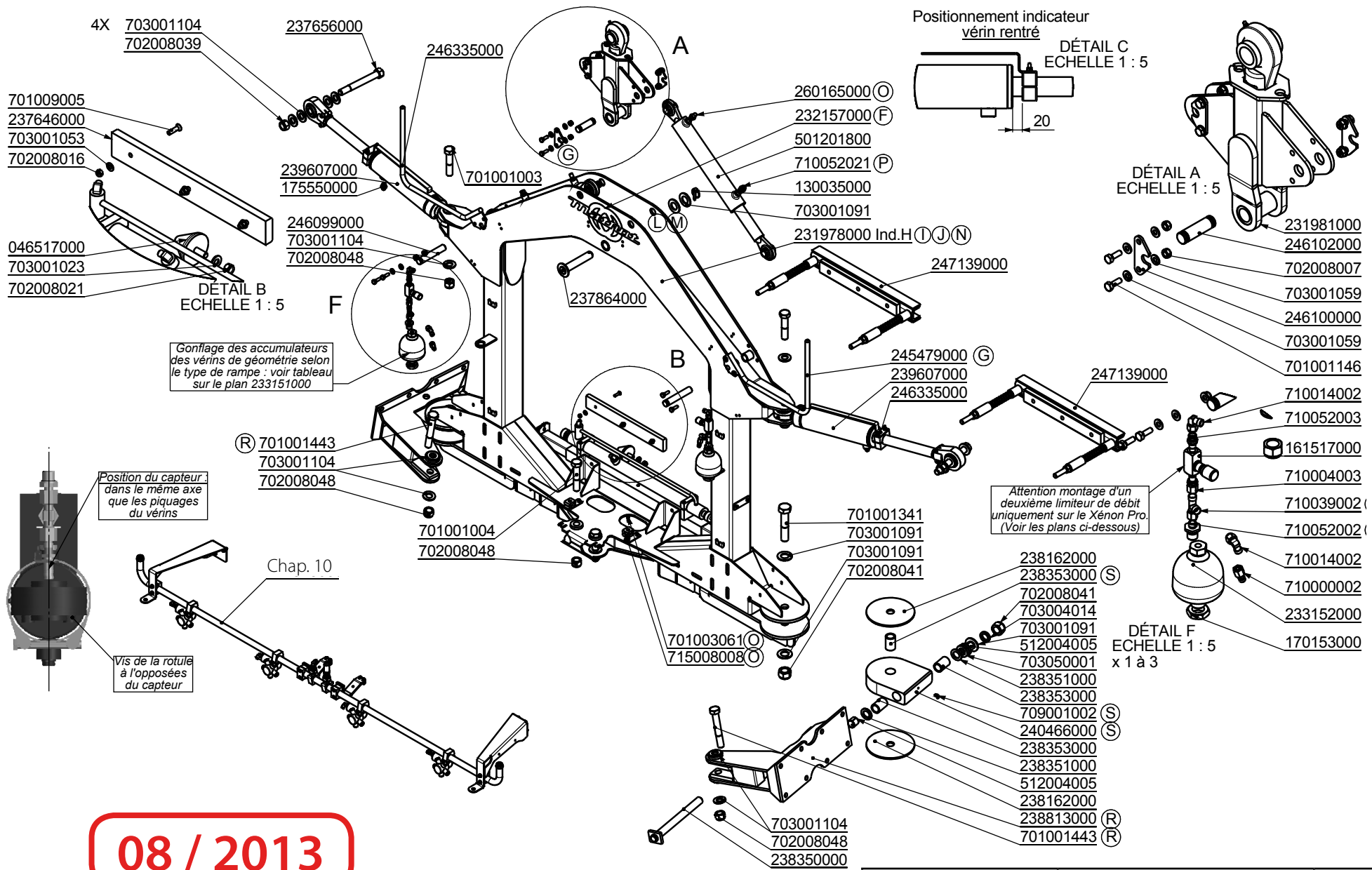

**08 / 2013**

Xénon 	Cadre équipé / Front frame	17.12.2013
	246184000	Chap. 01 P. 11

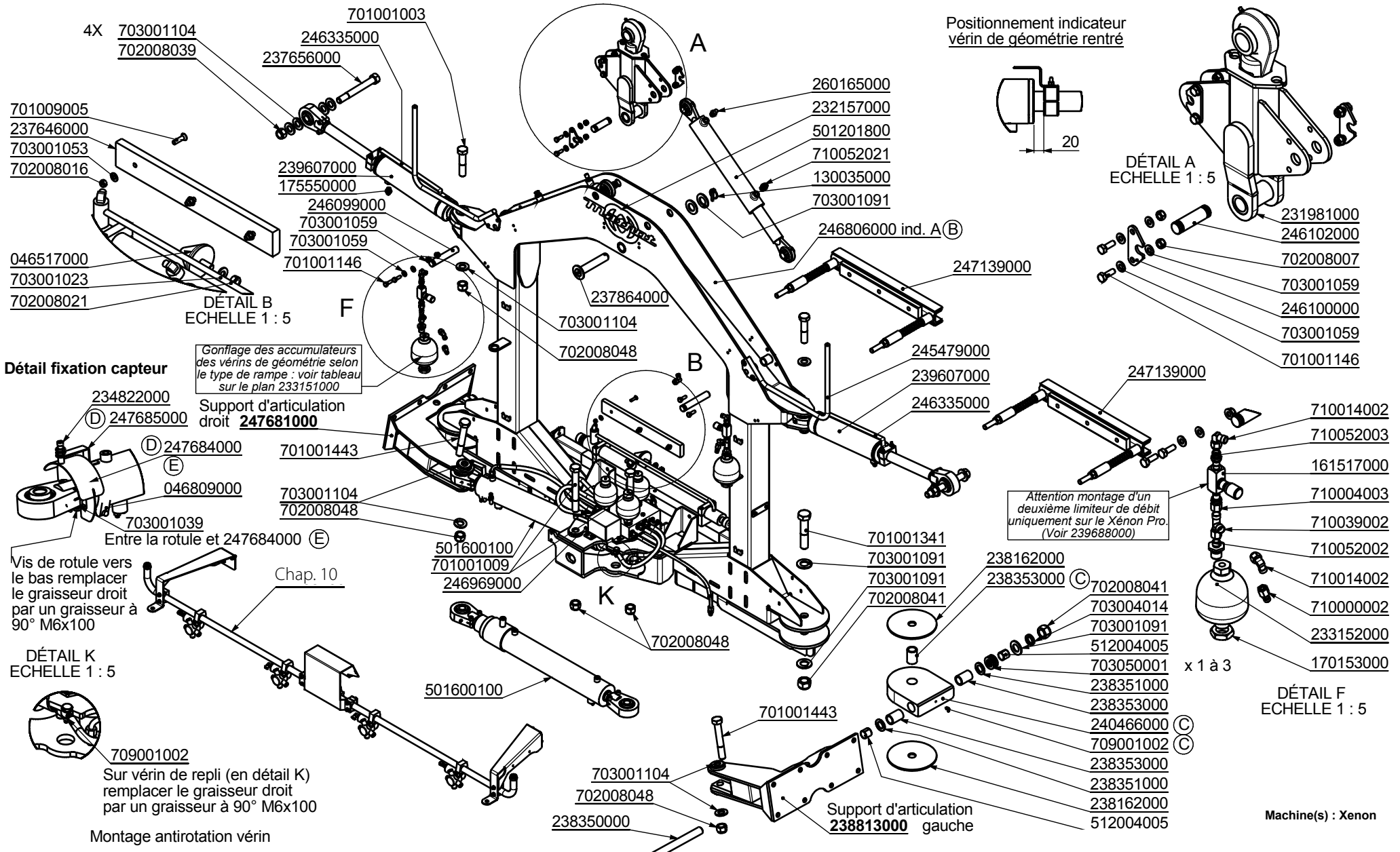

**06 / 2014**

Xénon	Cadre équipé Boom Flex/ Boom Flex Front frame	17.07.2014
<b>Mathot</b>		Chap. 01
246825000		P. 12

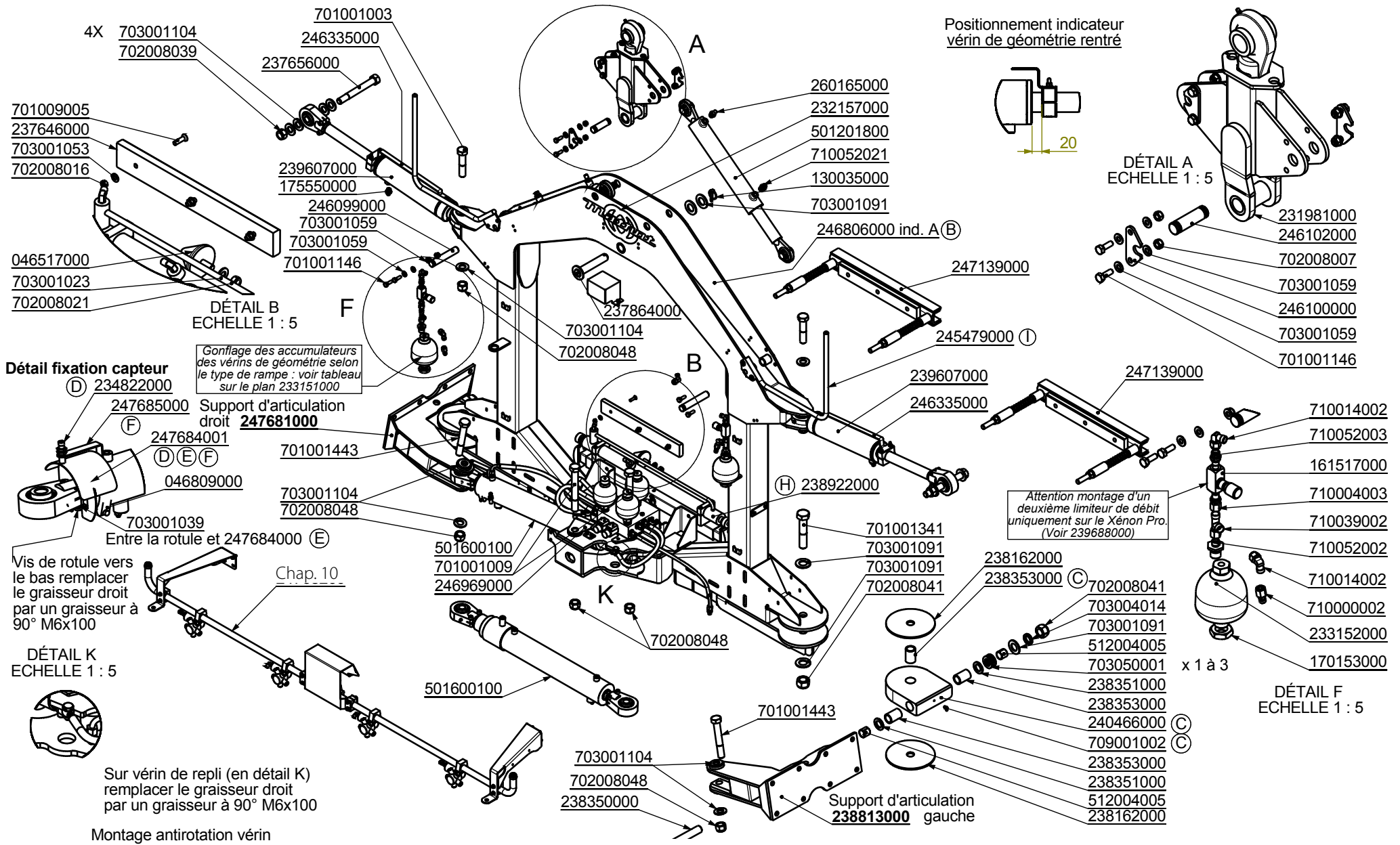

**03 / 2015**

Xénon 	Cadre équipé Boom Flex/ Boom Flex Front frame	13.03.2015
	246825000	Chap. 01 P. 13

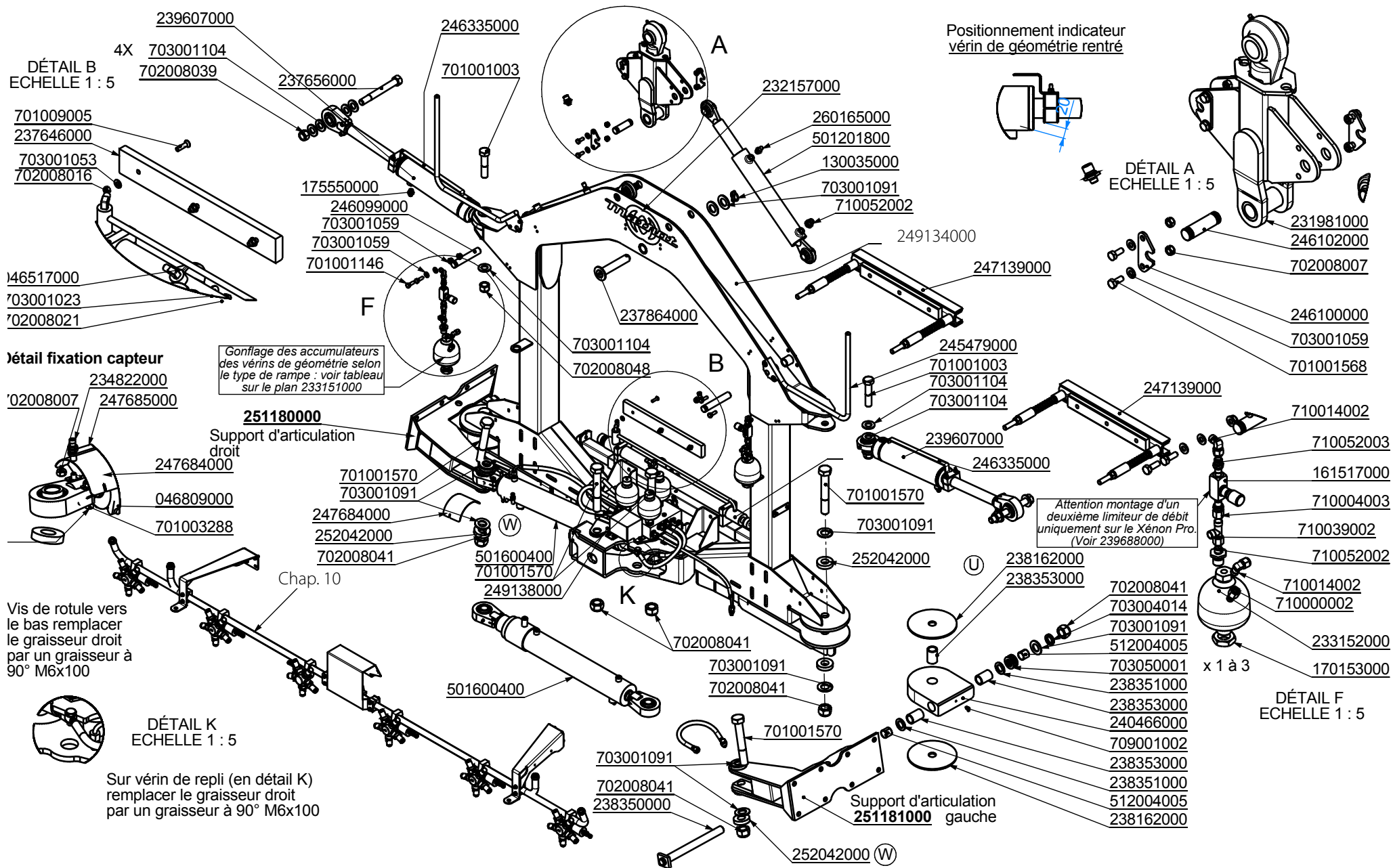

**07 / 2016** Boom Flex  
Diam 30

	Xénon	13.03.2015
	Cadre éq. Boom Flex «T»/ Boom Flex «T» Front frame	Chap. 01
	246825000	P. 14

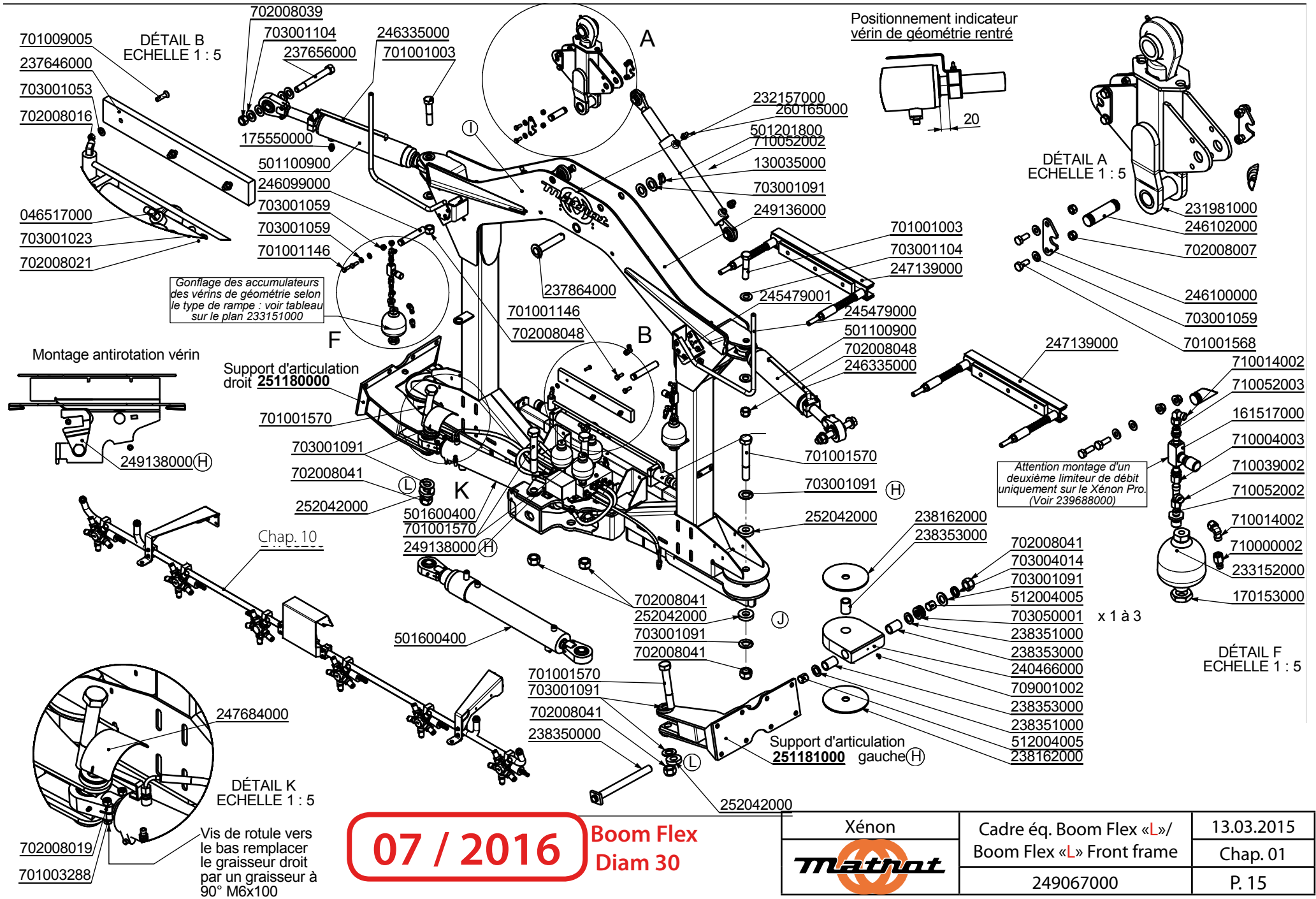

**07 / 2016**

**Boom Flex**  
**Diam 30**

<b>Xénon</b> 	Cadre éq. Boom Flex «L»/ Boom Flex «L» Front frame	13.03.2015
	249067000	Chap. 01 P. 15

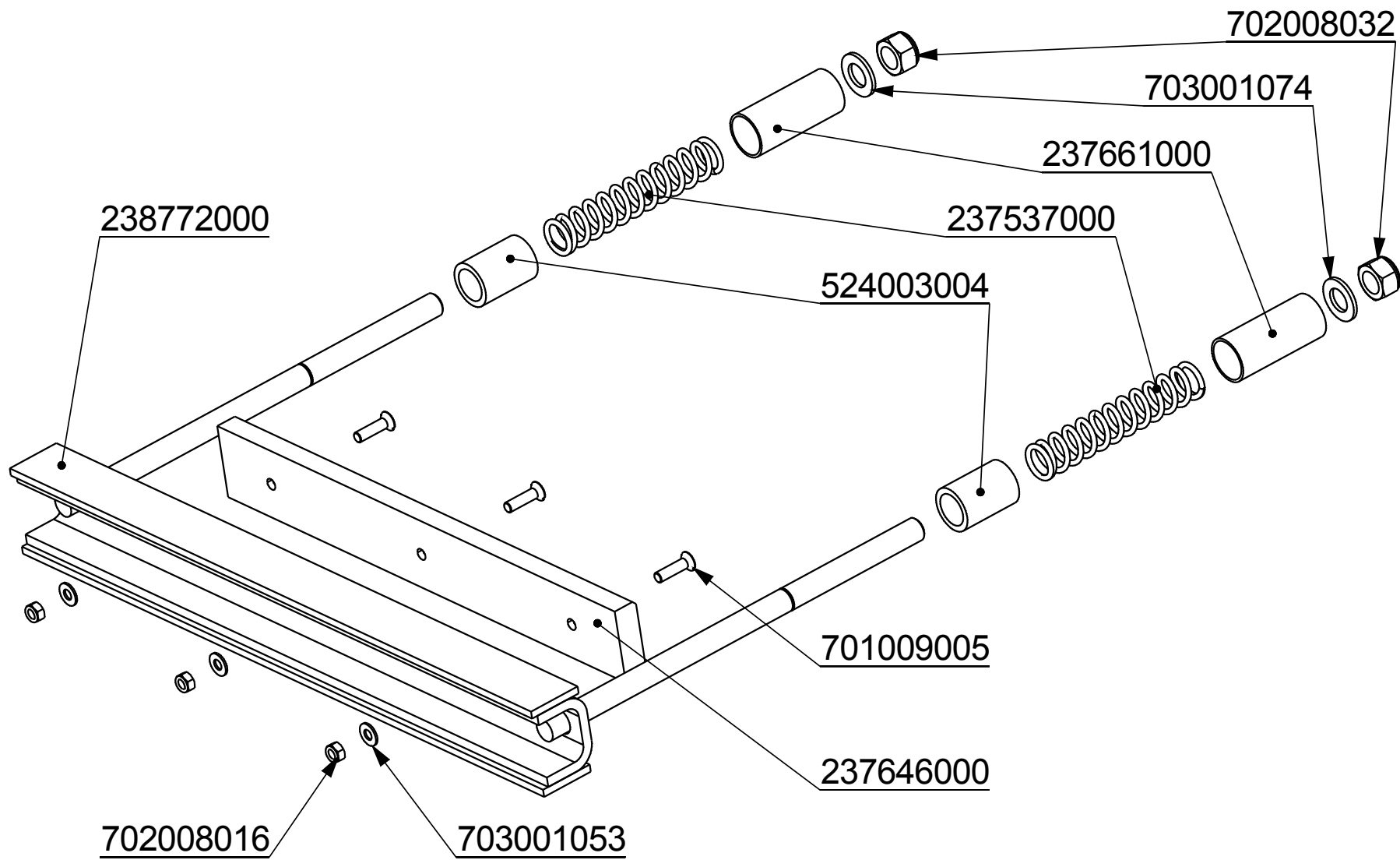

Xénon	Butée équipée	07.07.2011
<b>Mathot</b>		Chap. 01
	247139000	P. 16



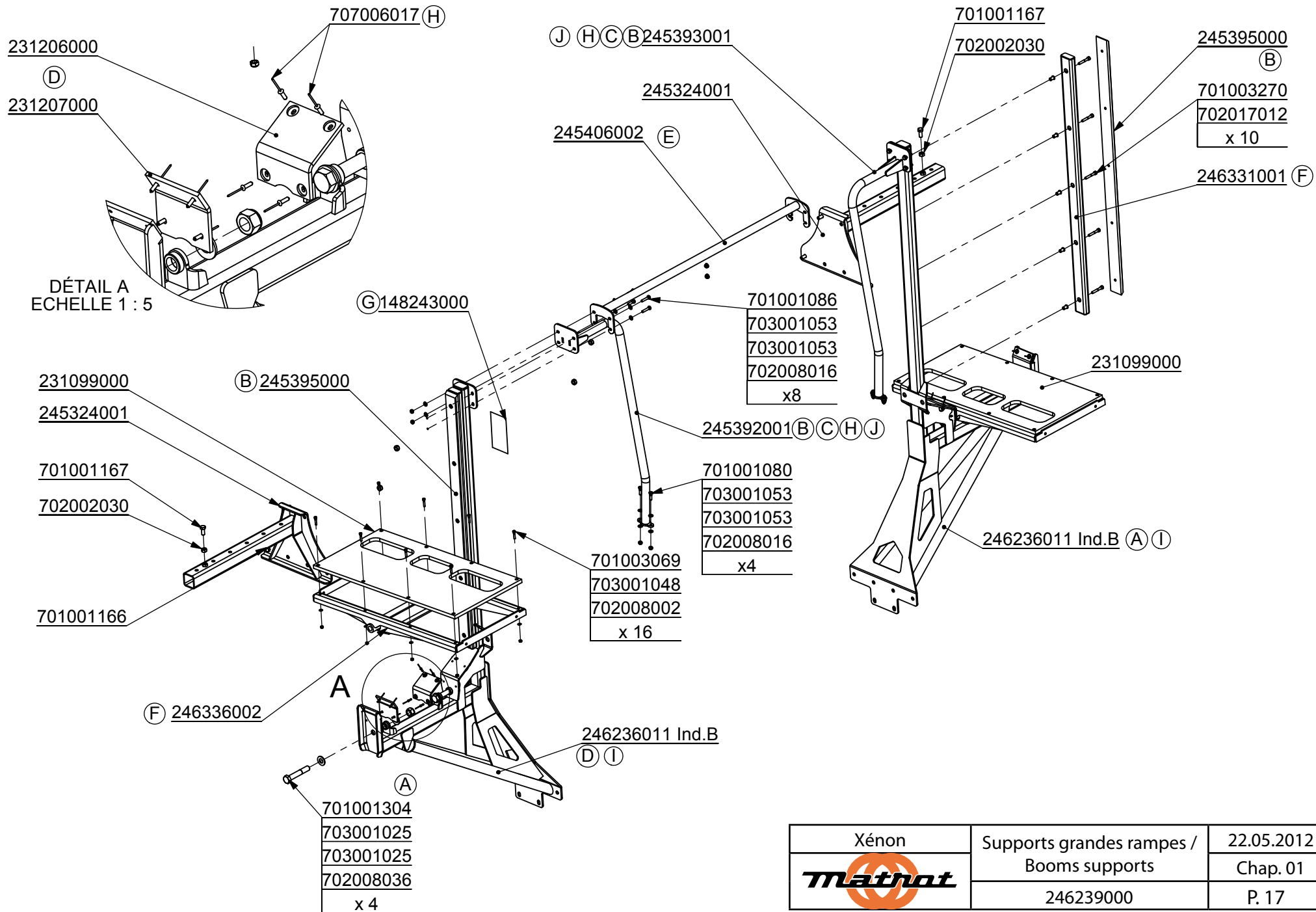

Xénon	Supports grandes rampes / Booms supports	22.05.2012
<b>Mathot</b>		Chap. 01
	246239000	P. 17

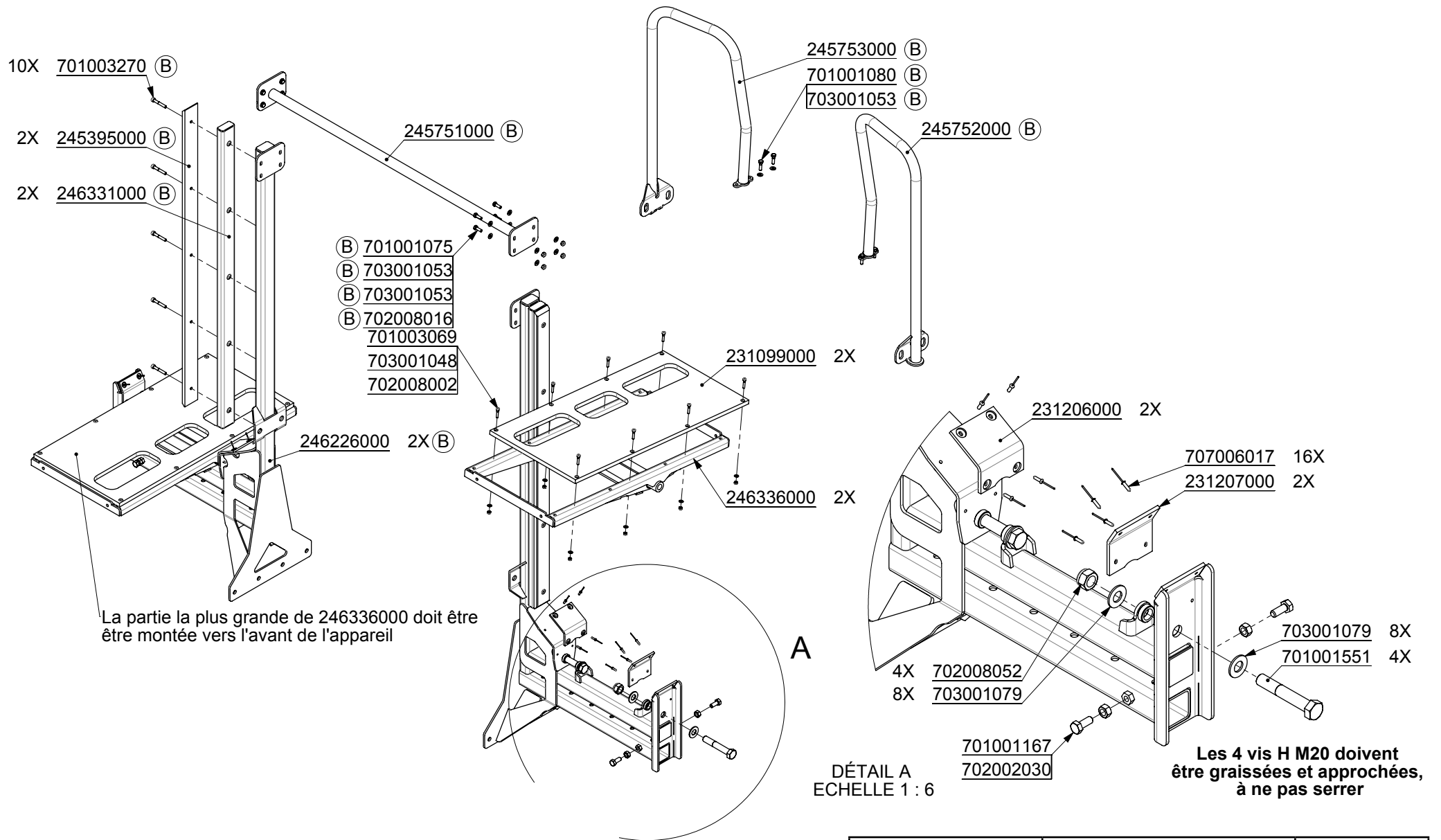

Xénon	Supports grandes rampes / Booms supports	22.05.2012
<b>Mathot</b>	246239000	Chap. 01
		P. 18

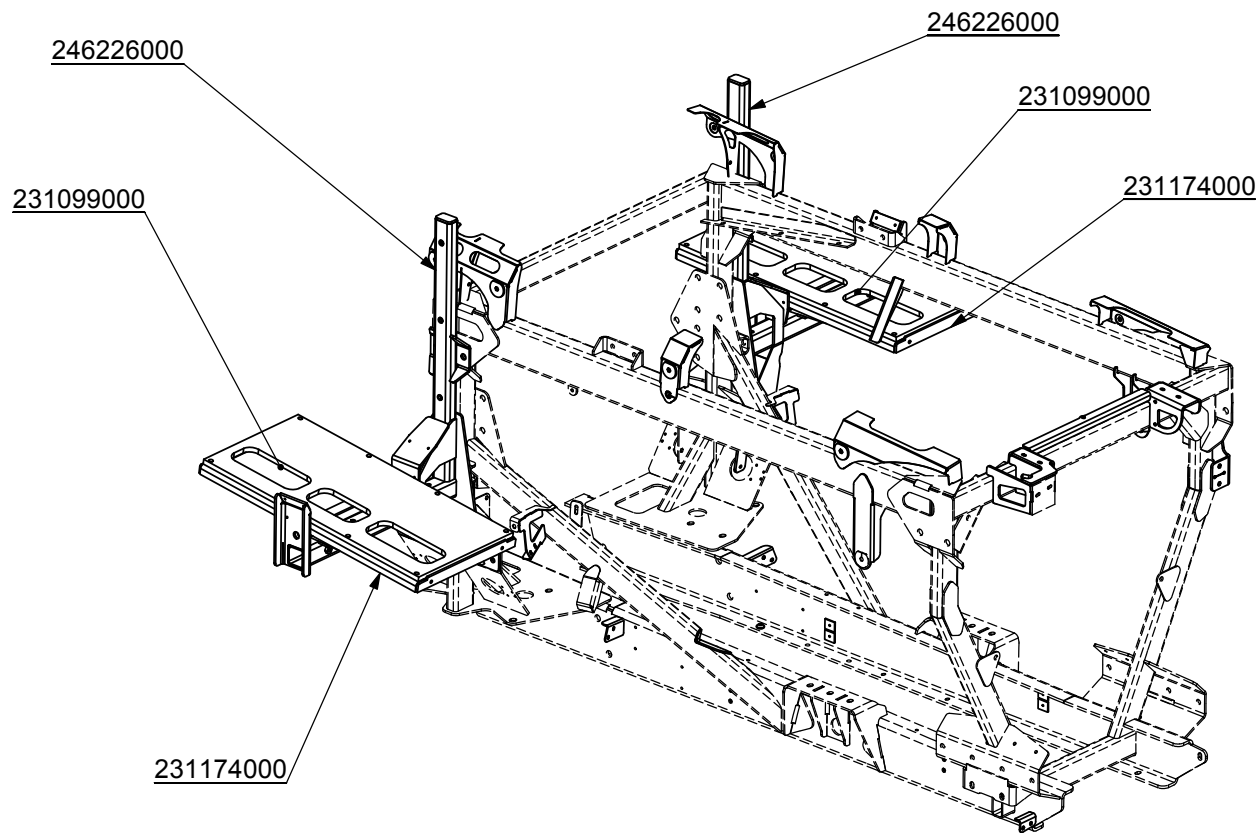

Xénon	Support petites rampes / Shorts booms supports	19.10.2010
<b>Mathot</b>		Chap. 01
	246313000	P. 19

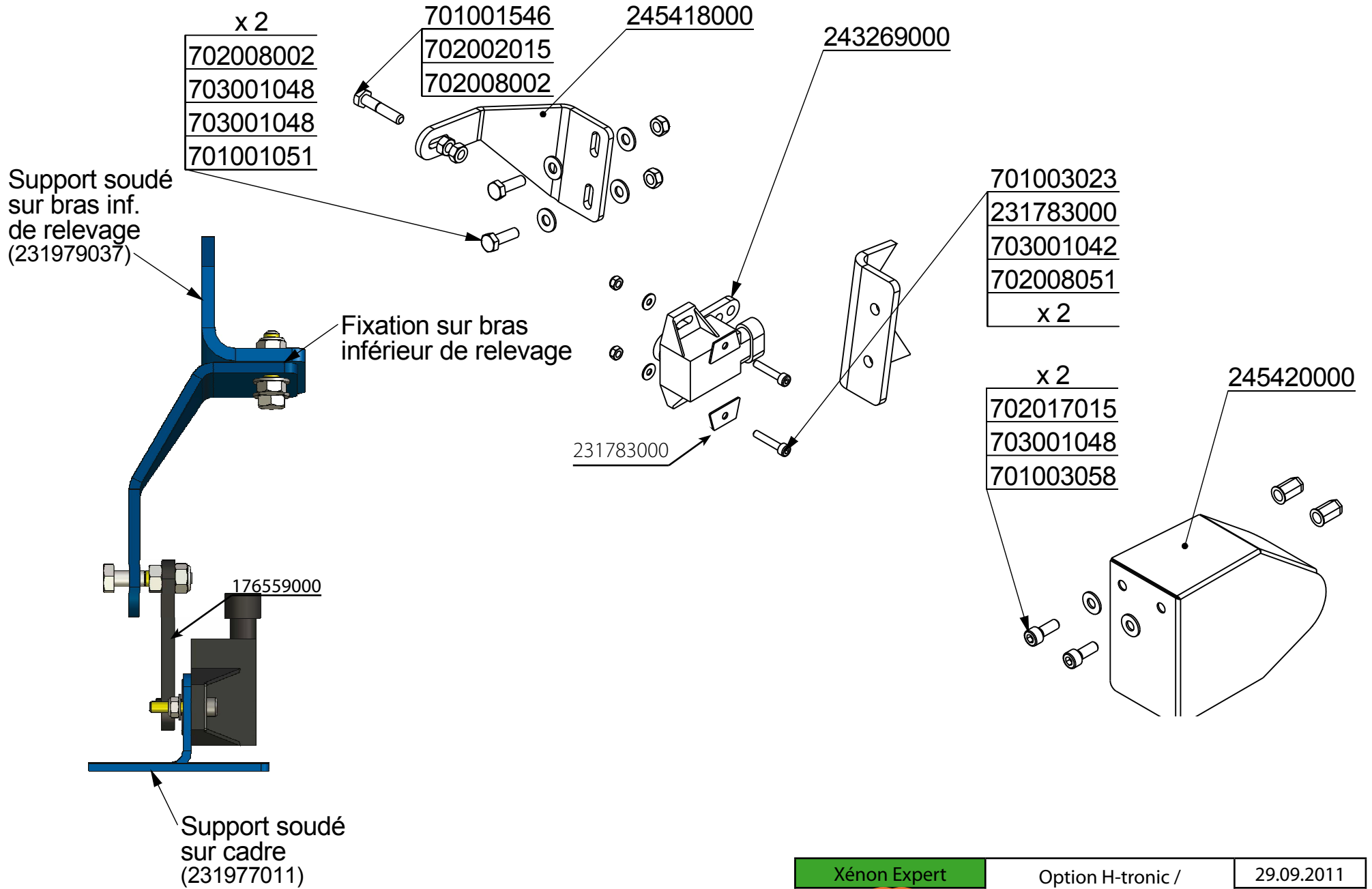

Xénon Expert 	Option H-tronic / H-tronic Option	29.09.2011
	247167000	Chap. 01 P. 20

① Raccords su  
(voir plan 2396)

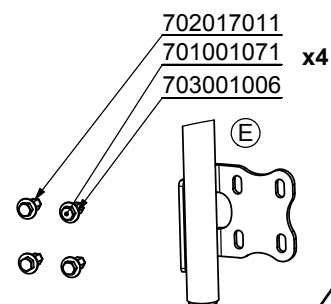
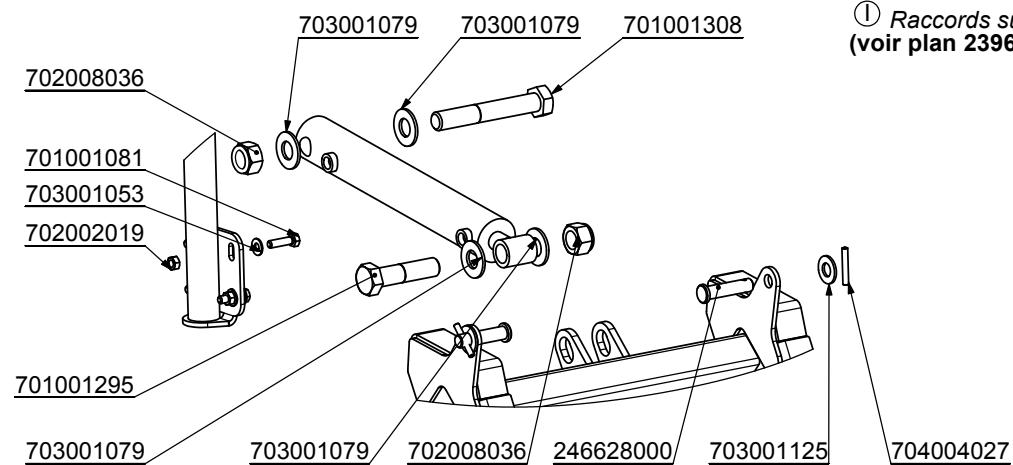
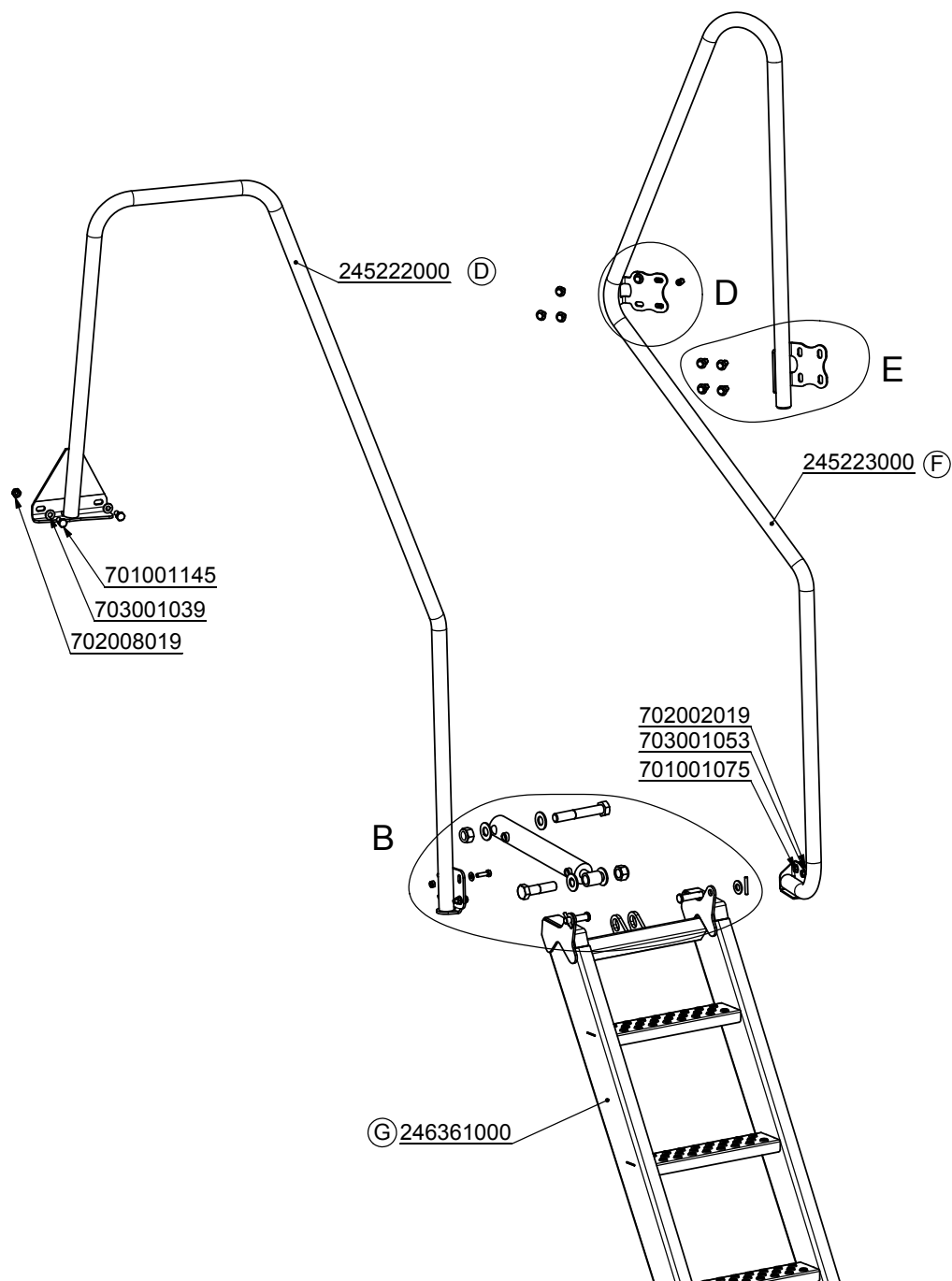

DÉTAIL E  
ECHELLE 1 : 4

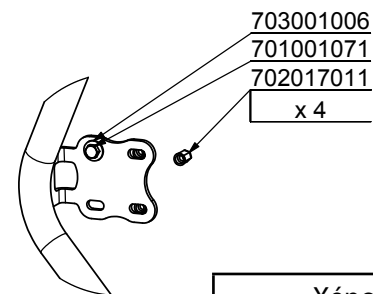
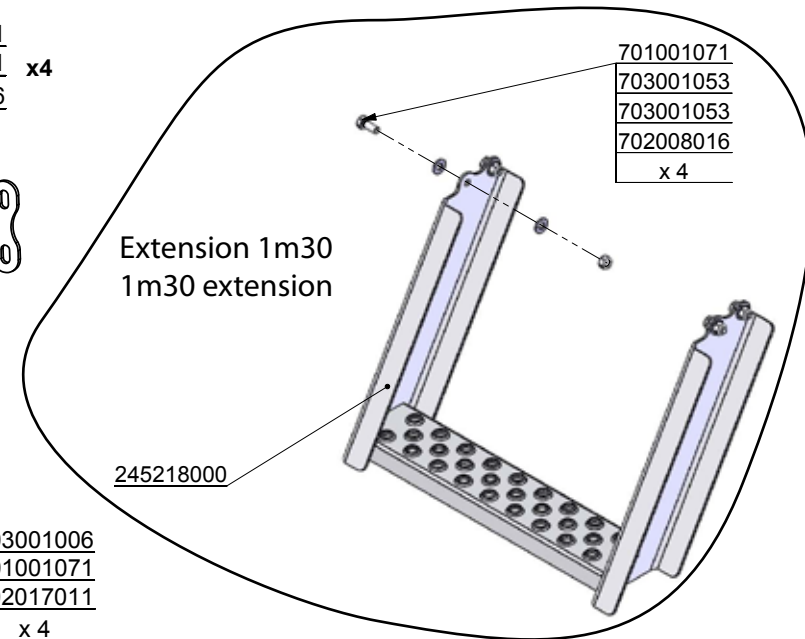

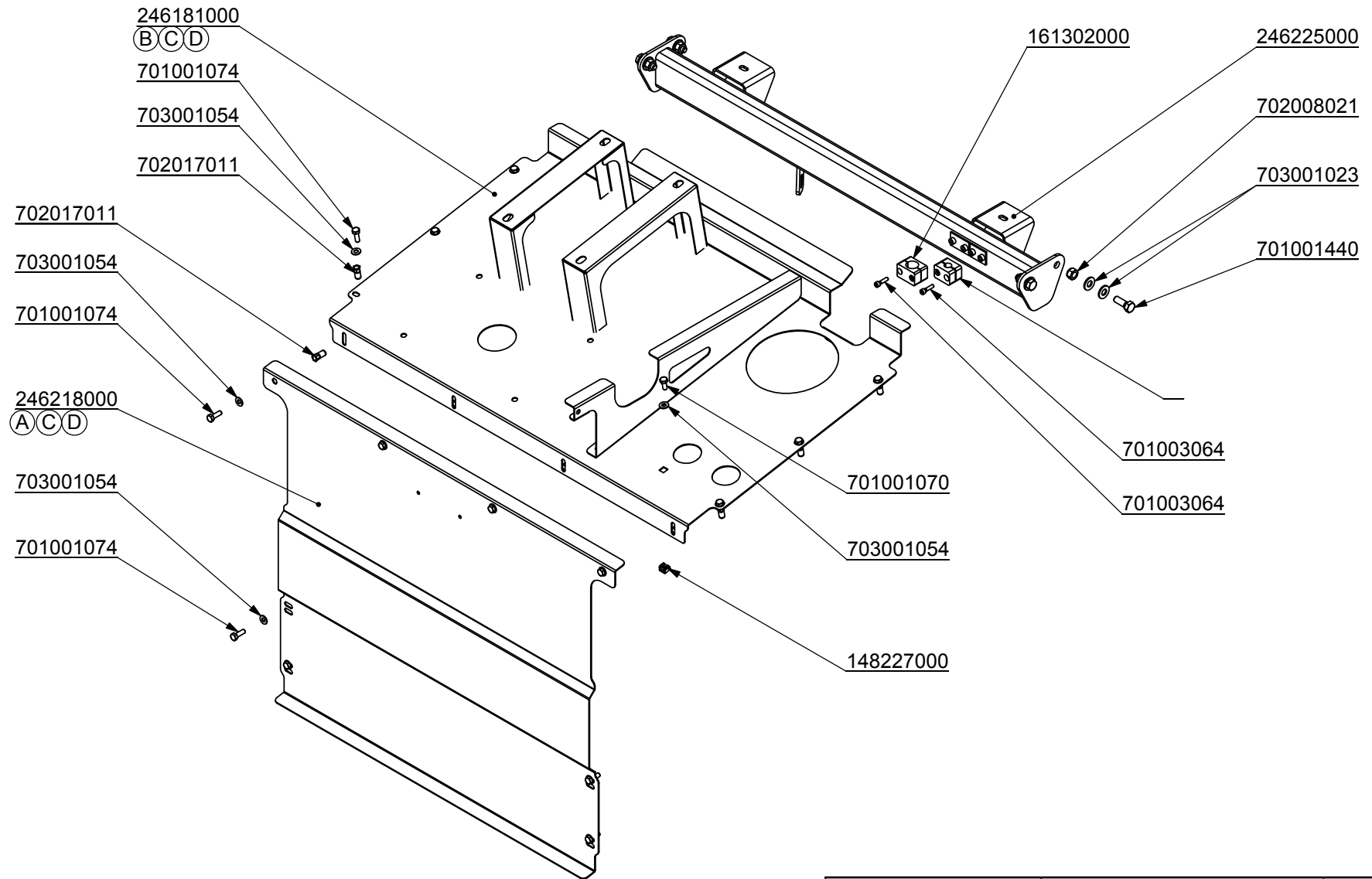

DÉTAIL D

Xénon	Echelle avant / Front Lader	07.01.2014
<b>Mathot</b>	245219000	Chap. 01
		P. 21

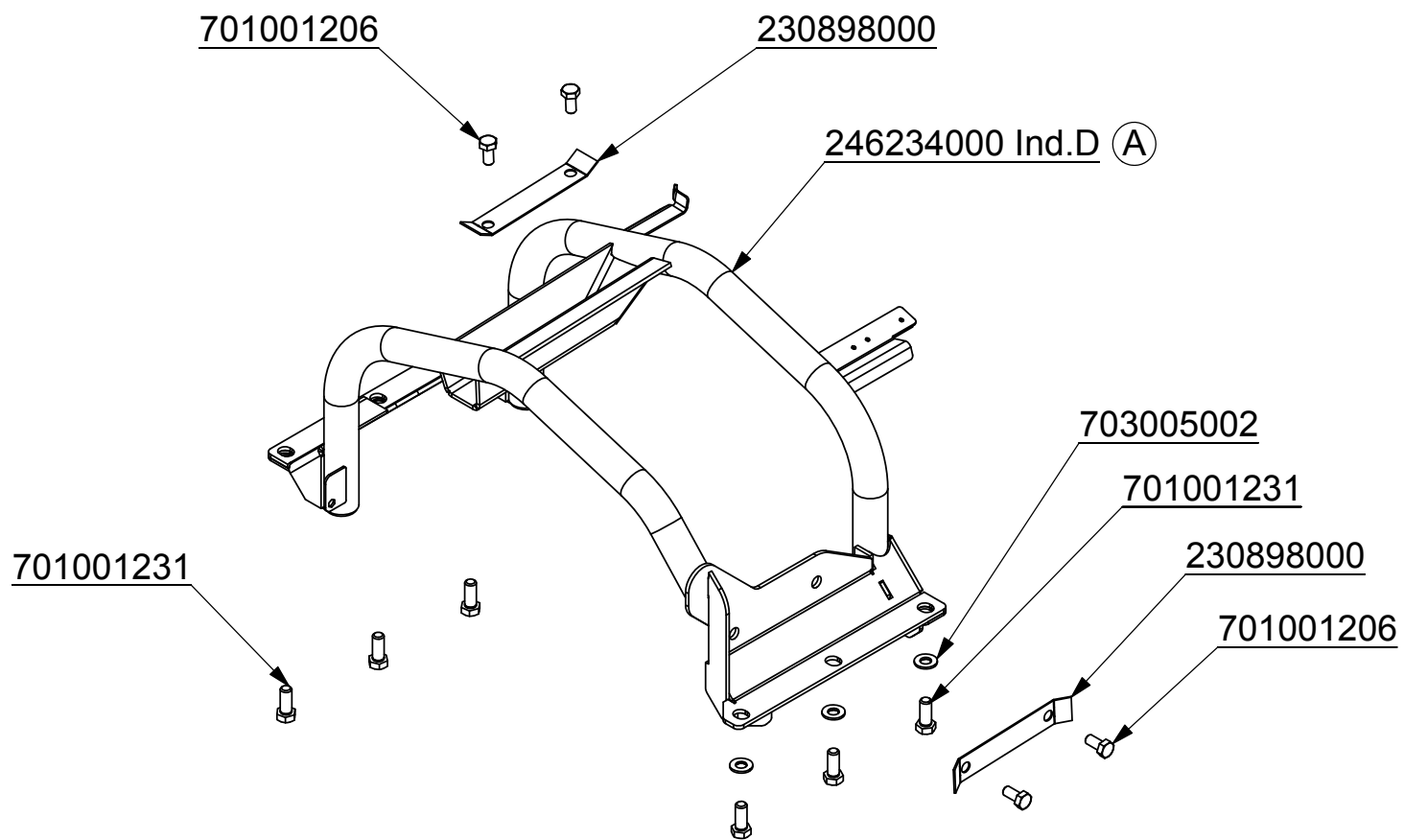

Xénon	Plateforme / Platform	28.09.2012
<b>Mathot</b>		Chap. 01
	242393000	P. 22



Xénon	Support boîte de vitesse / Gear box support	16.06.2011
		Chap. 01
	246251000	P. 23

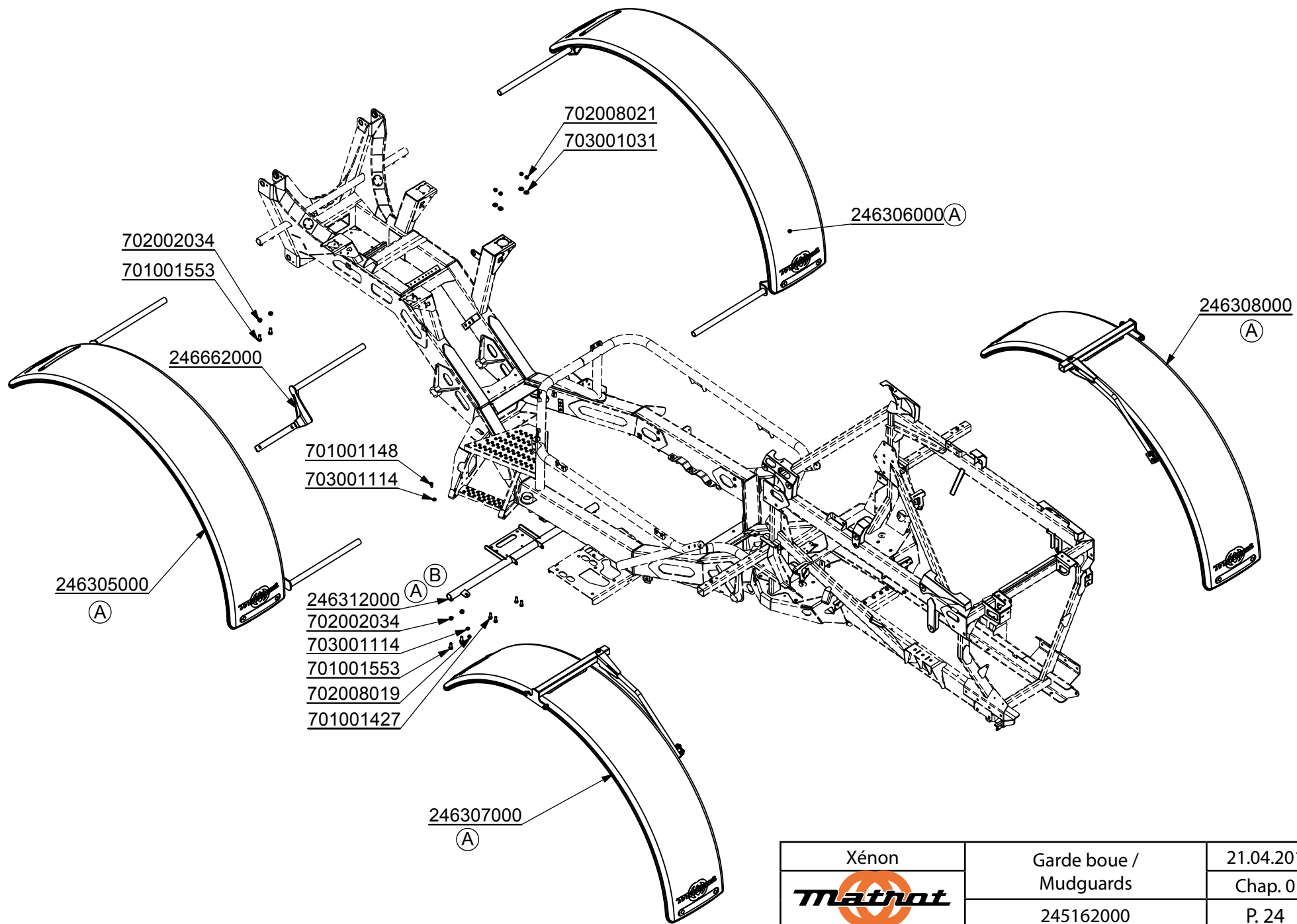

Xénon	Garde boue / Mudguards	21.04.2011
<b>Mathot</b>		Chap. 01
	245162000	P. 24



701017023

246304000

245238000

246302000

246303000 (A)

702008019

246303000 (A)

702008019

246304000

701017023

Xénon	Garde boue Avant Gauche Front left Mudguards	21.04.2011
	246305000	Chap. 01
		P. 25

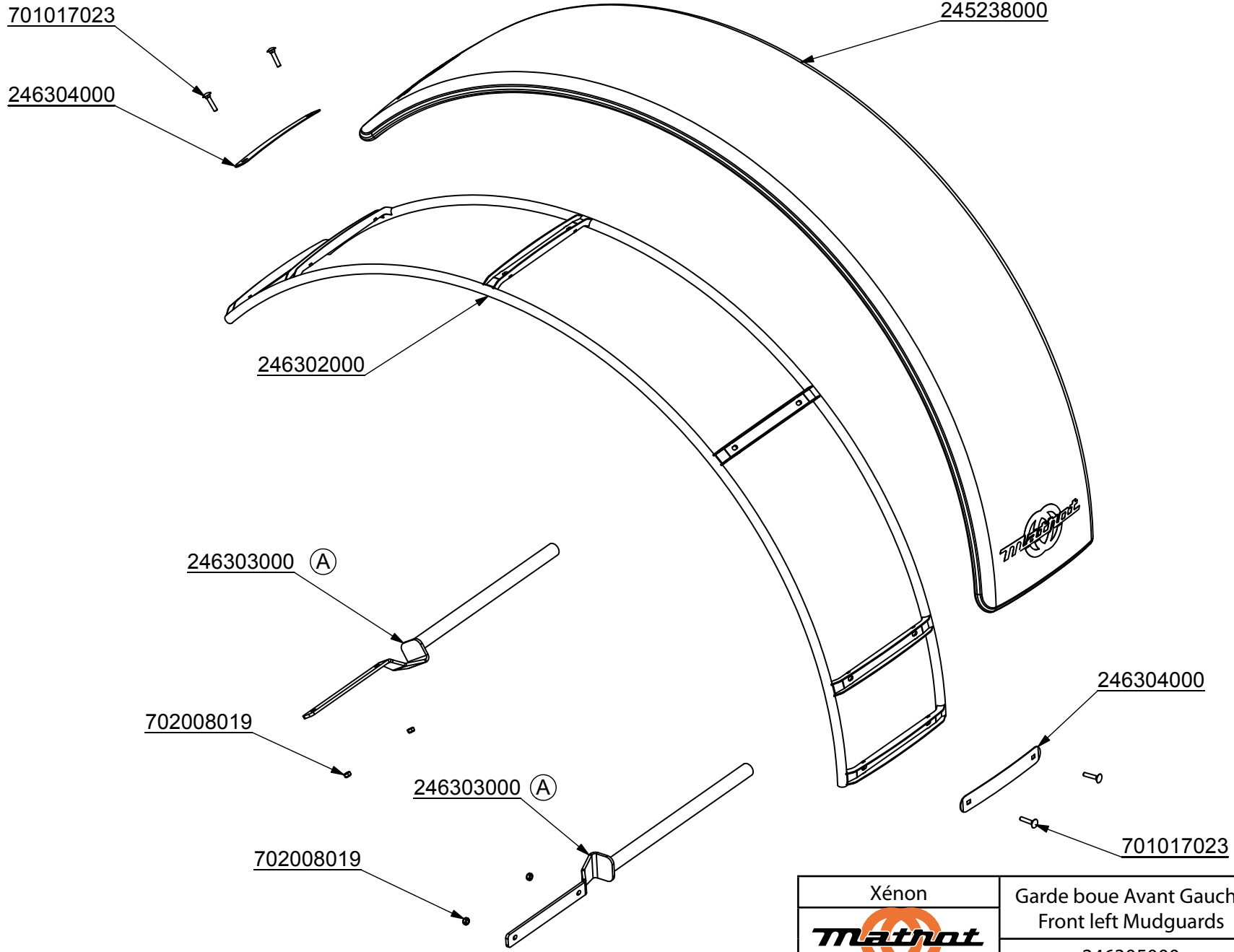

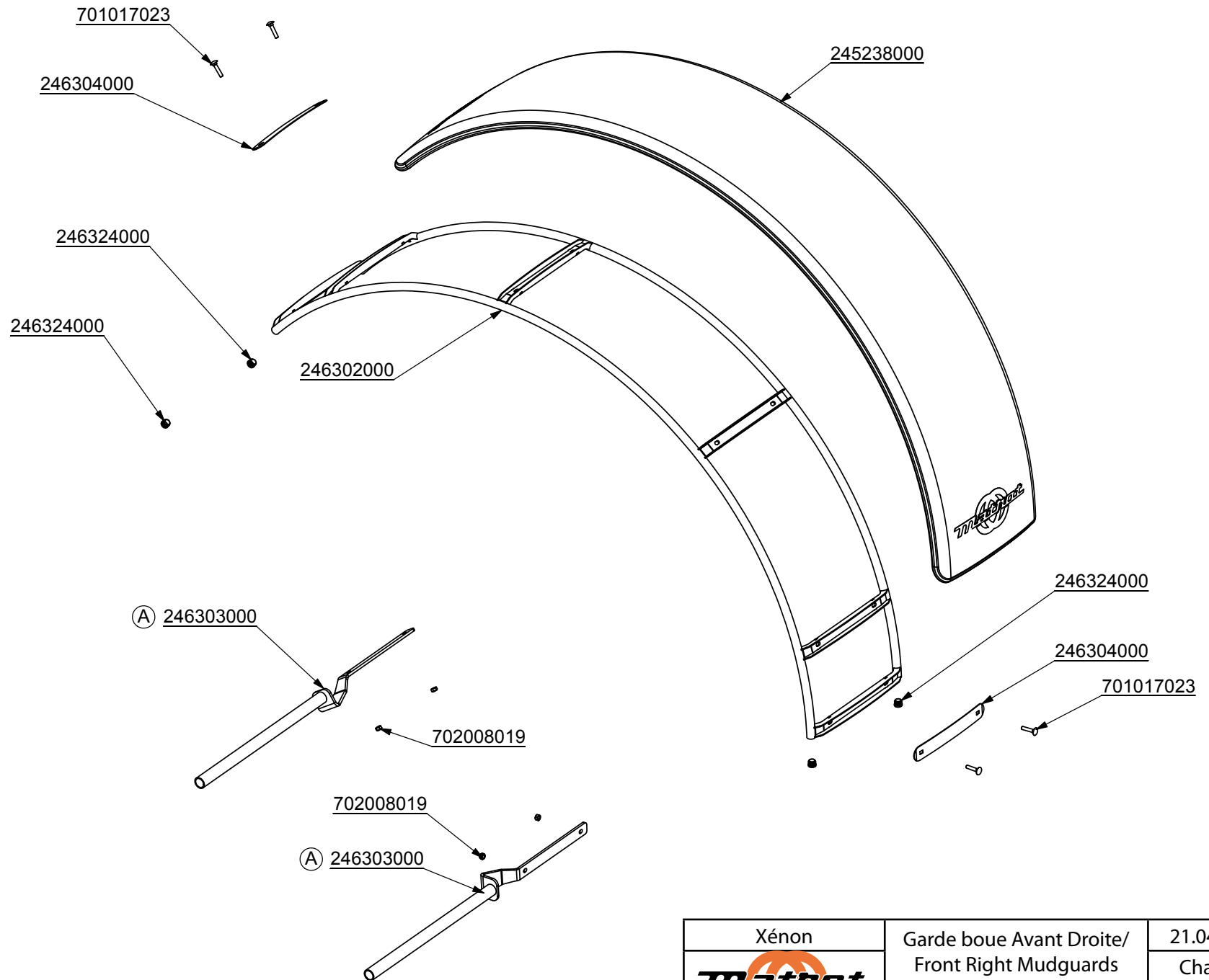

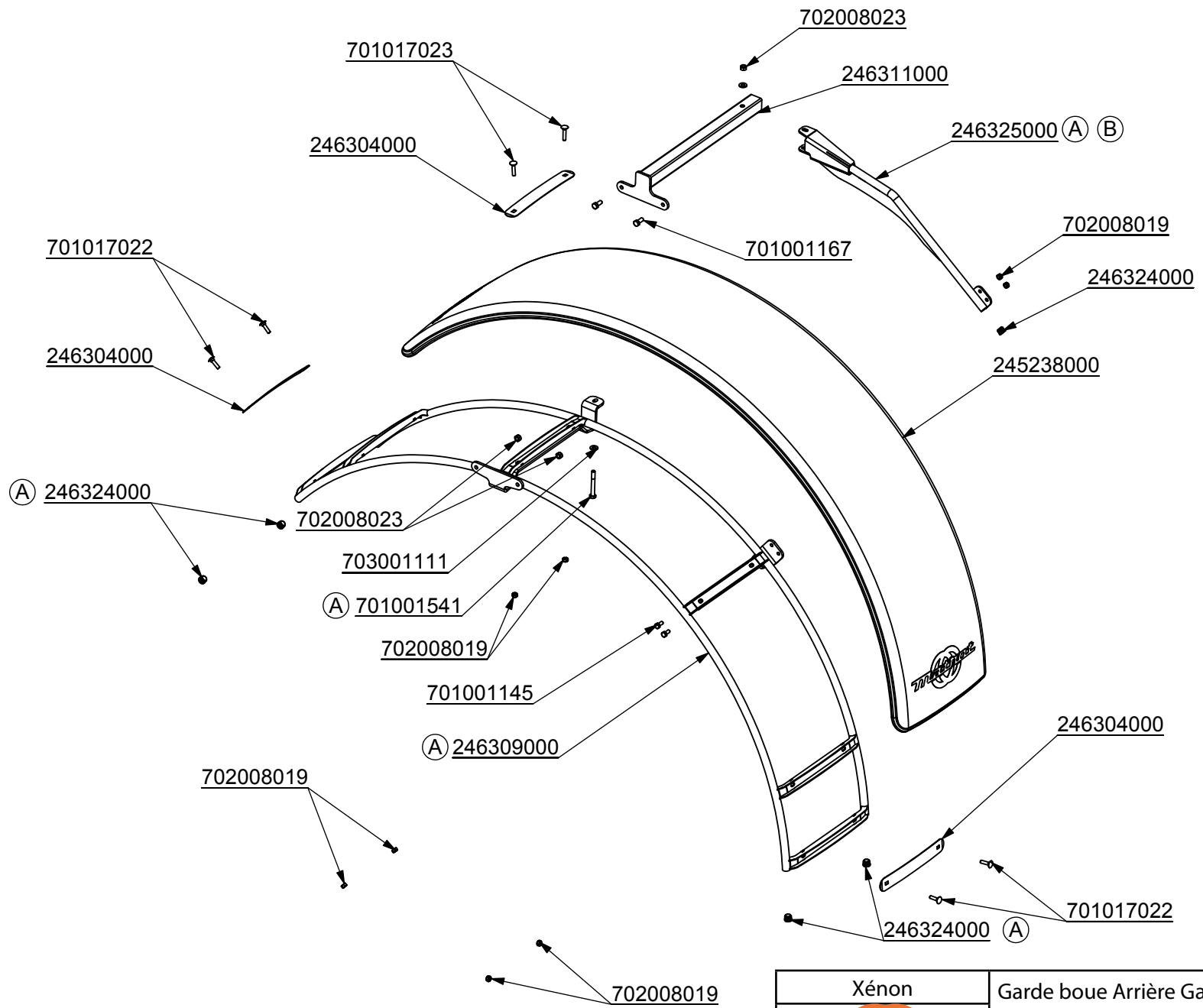

Xénon	Garde boue Avant Droite/ Front Right Mudguards	21.04.2011
<b>Mathot</b>	246306000	Chap. 01
		P. 26

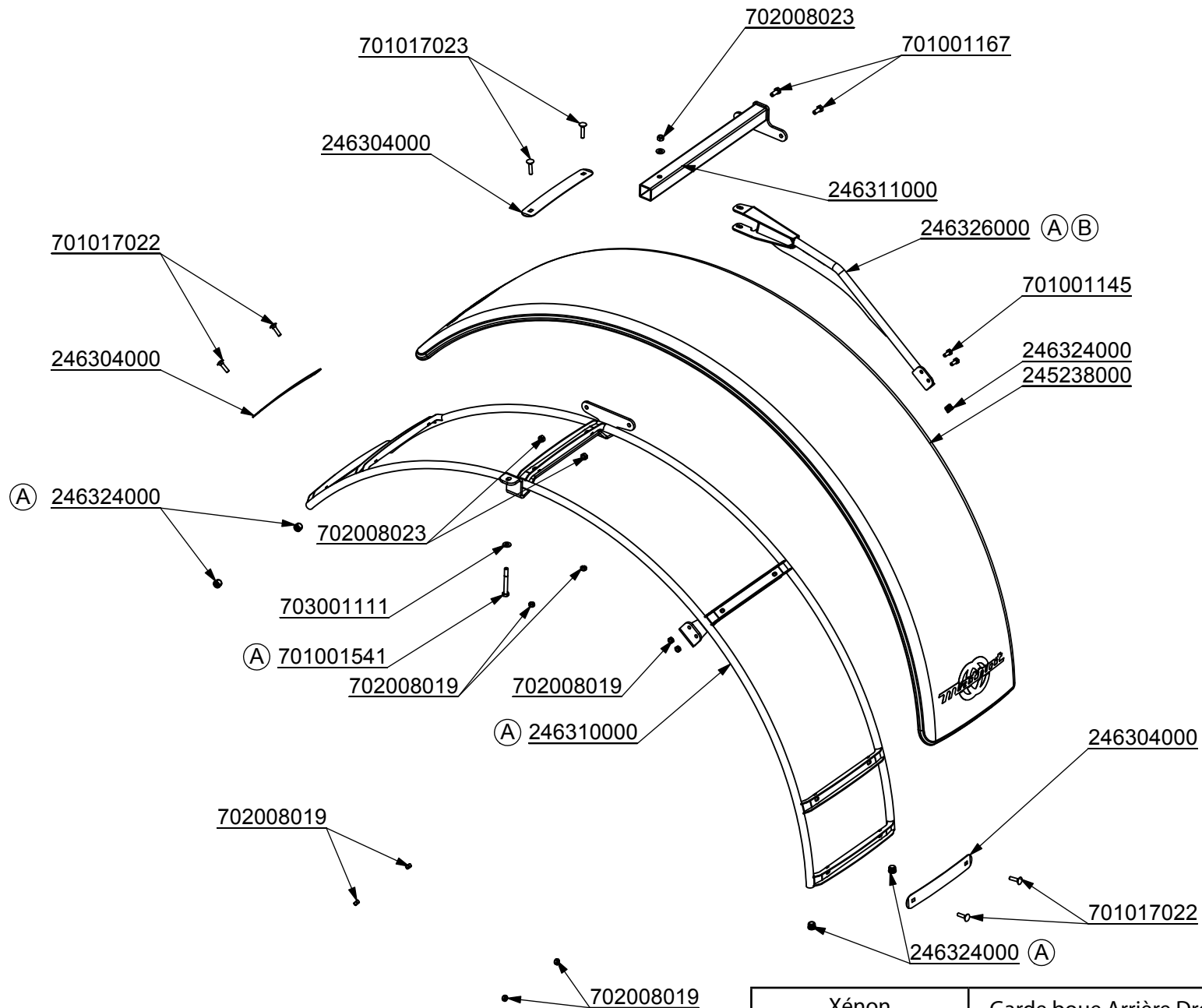

Xénon	Garde boue Arrière Gauche/ Rear Left Mudguards	21.04.2011
<b>Matnot</b>	246307000	Chap. 01
		P. 27



Xénon	Garde boue Arrière Droit/ Rear Right Mudguards	21.04.2011
	246308000	Chap. 01
		P. 28

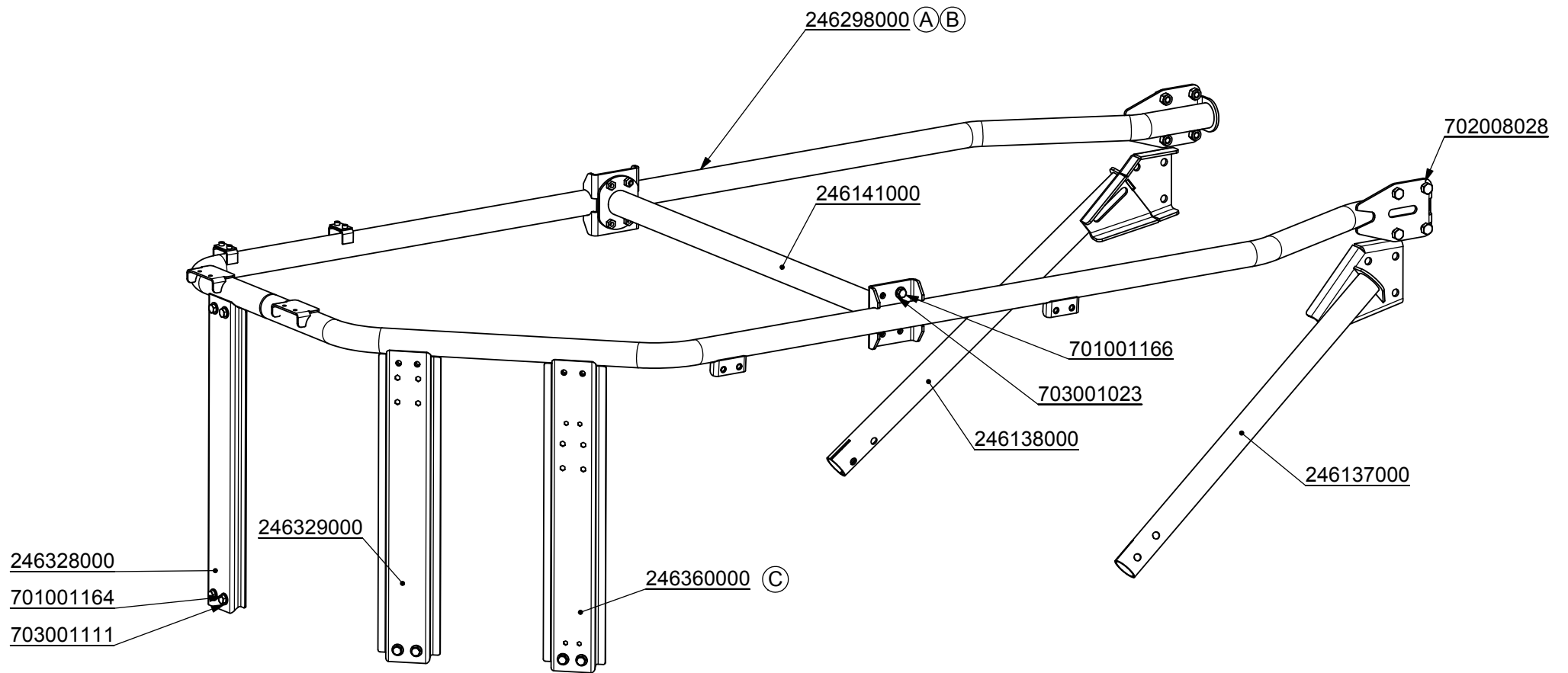

Xénon	Ceinture de cuve	27.03.2013
<b>Mathot</b>		Chap. 01
	245495000	P. 29

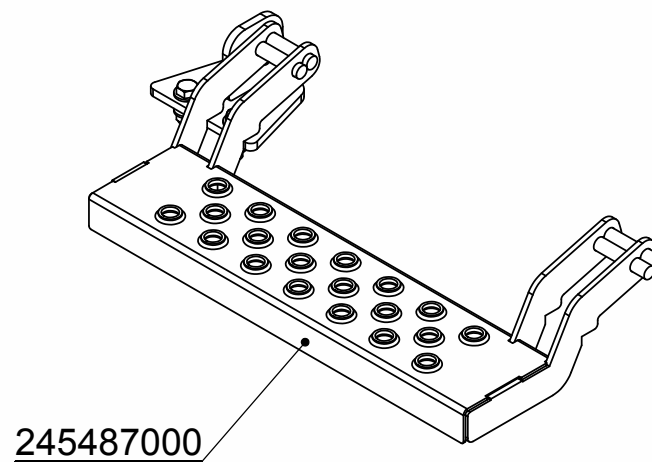
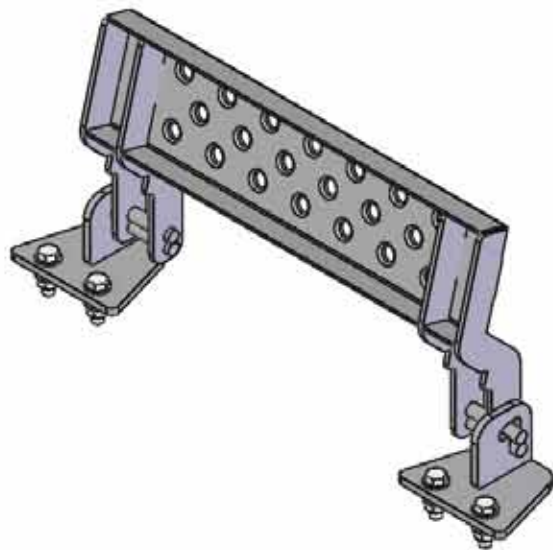

245487000

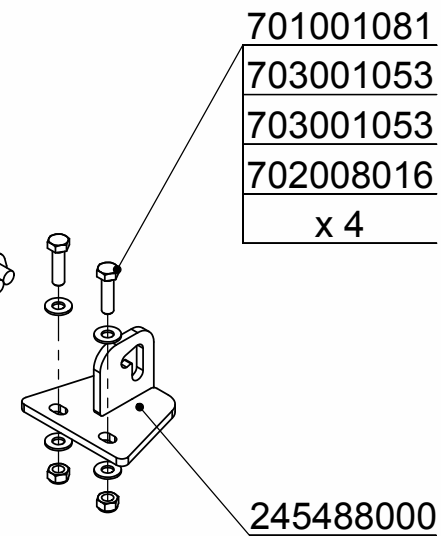

701001081  
 703001053  
 703001053  
 702008016  
 x 4

245488000

Xénon	Marche Ceinture de cuve	27.03.2013
<b>Mathot</b>		Chap. 01
	245486000	P. 30

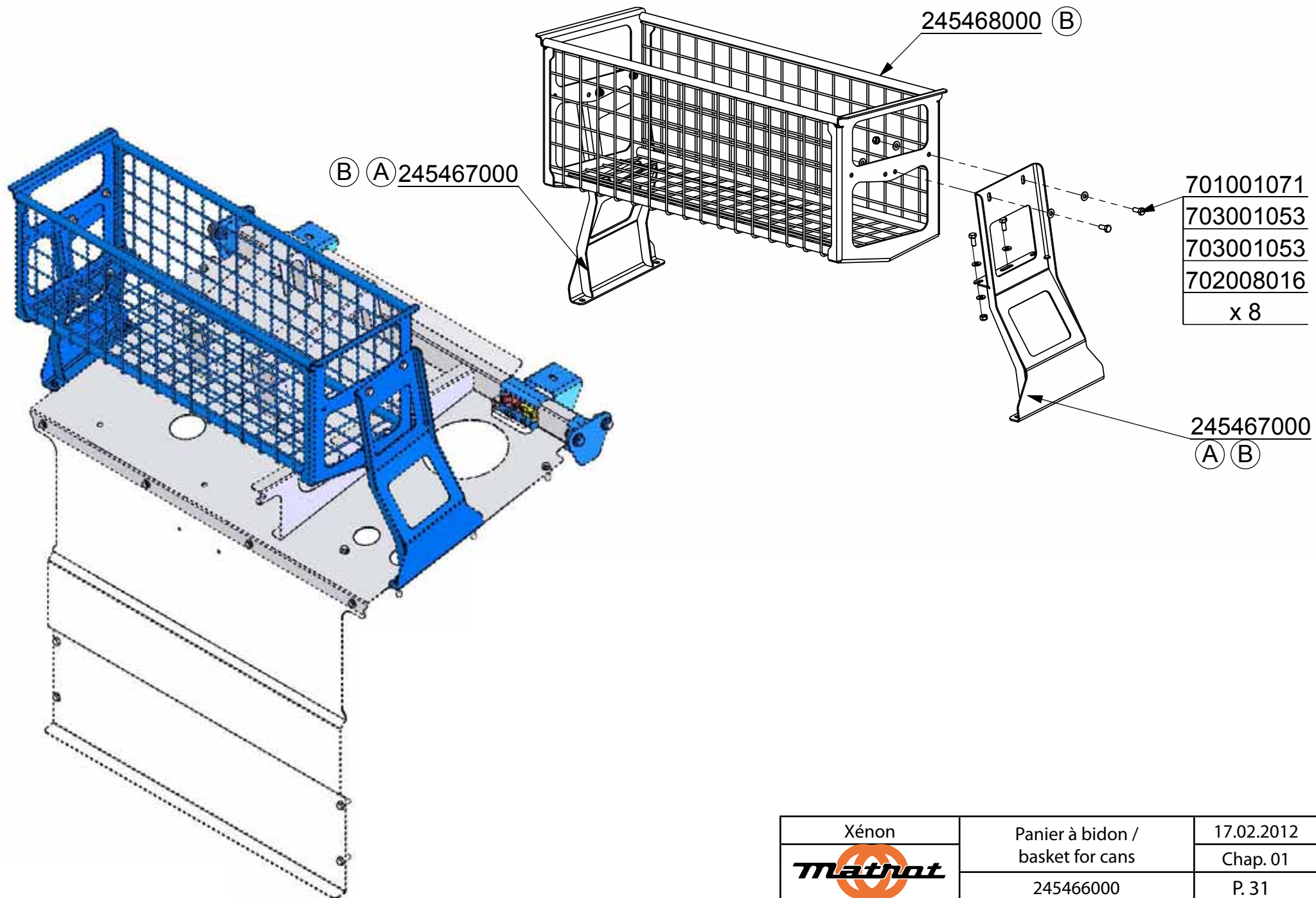

Xénon	Panier à bidon / basket for cans	17.02.2012
	245466000	Chap. 01
		P. 31

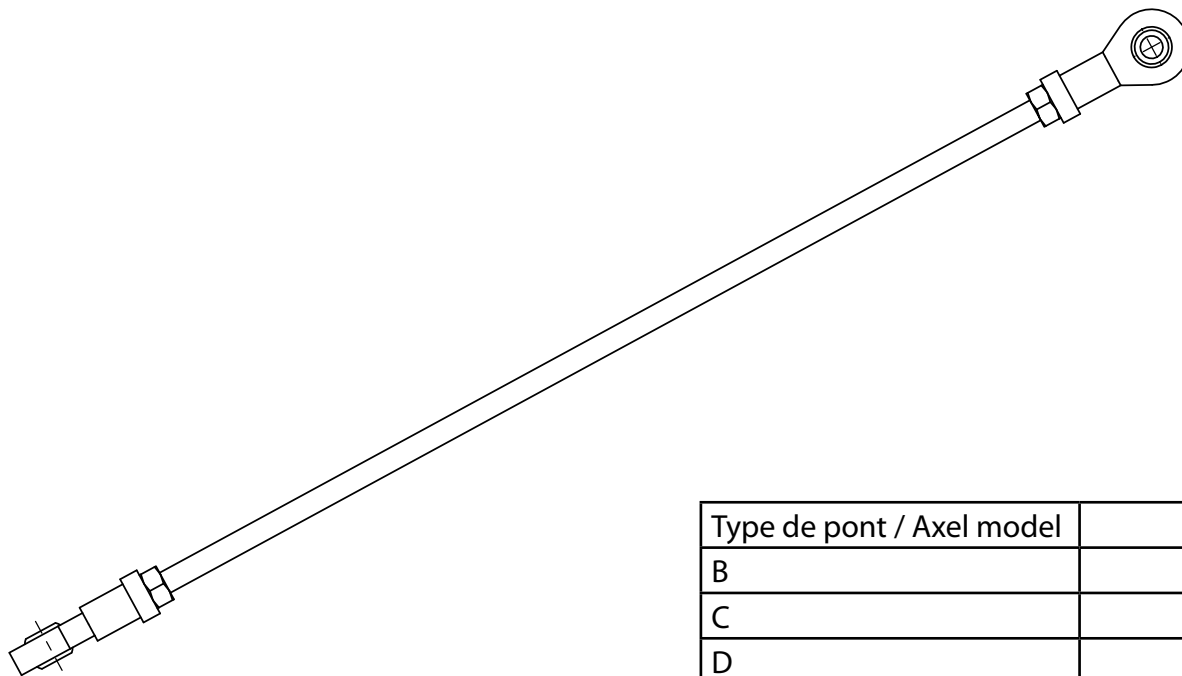

Type de pont / Axel model		Ref.
B		246352000
C		246356000
D		246357000
E		246358000

Xénon	Bielle autoguidage / Autosteering connecting rod	12.10.2010
	/	Chap. 01
		P. 32