

Km/h	25	40
17/39	X	X
21/39	X	X
23/45	X	

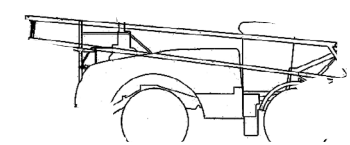
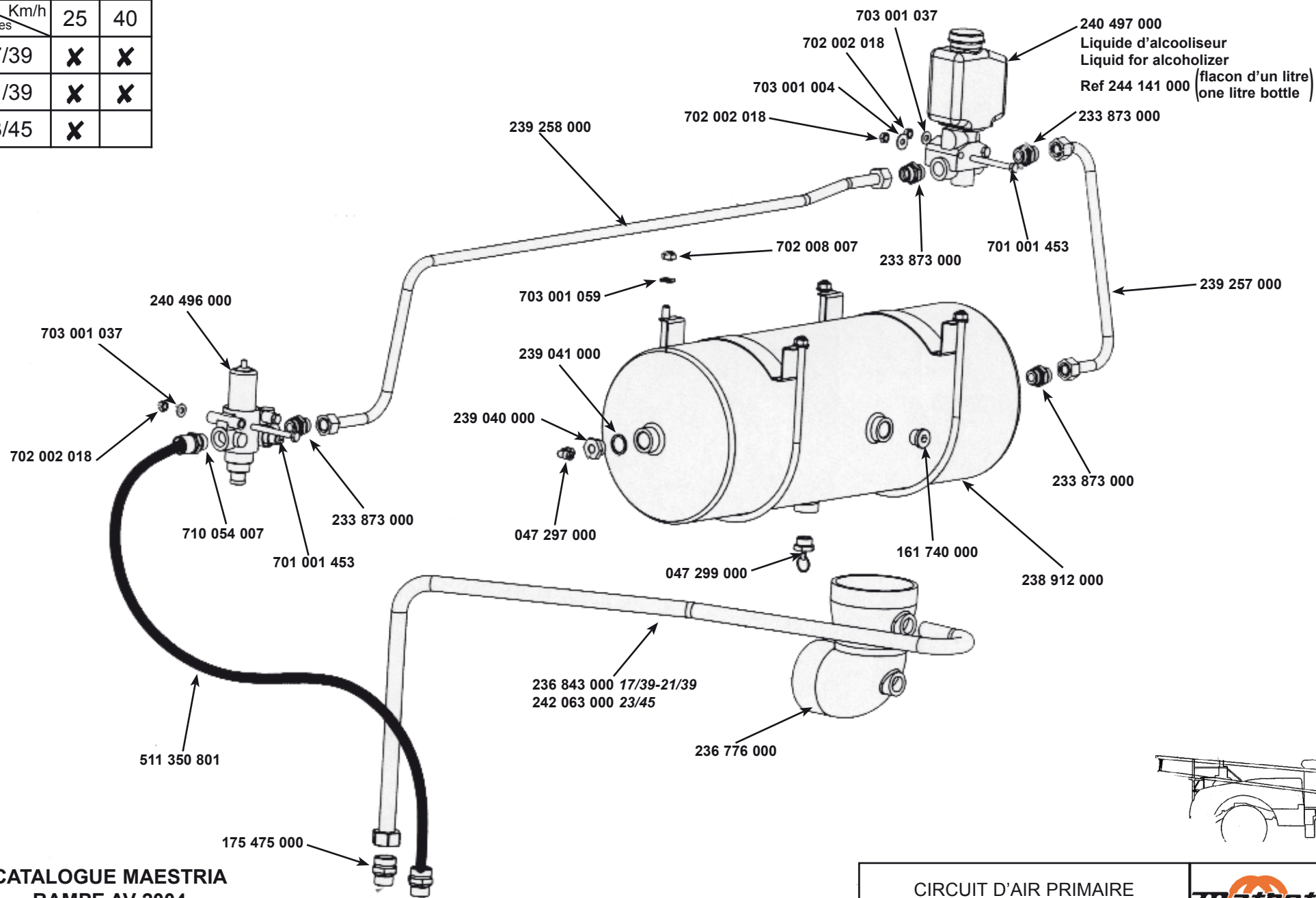

CATALOGUE MAESTRIA
RAMPE AV 2004
Correctif mars 2009/March 2009 correction

CIRCUI D'AIR PRIMAIRE PRIMARY AIR CIRCUIT		5 A01 08/07/05
--	---	------------------------------------

Km/h	25	40
17/39	X	X
21/39	X	X
23/45	X	

Liquide d'alcooliseur
Liquid for alcoholizer
Ref. 244 141 000 (flacon d'un litre
one litre bottle)

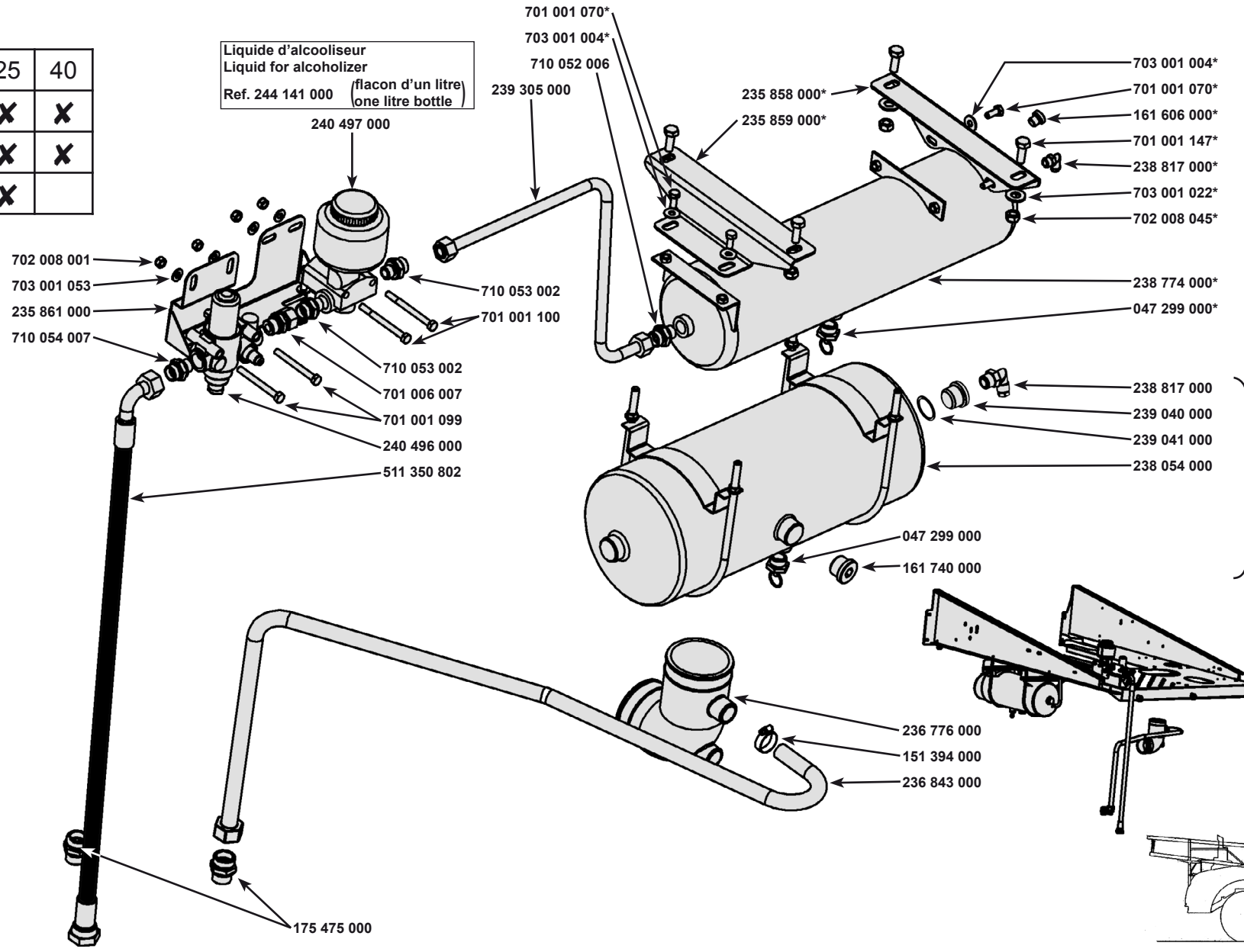

Remplace
l'ensemble
des références
marquées d'un *.
~~~~~  
Replace the whole  
of the references  
marked of one \*.

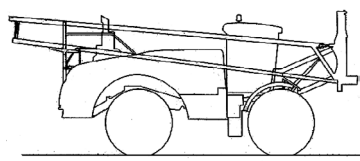

| Modèles \ Km/h | 25 | 40 |
|----------------|----|----|
| 17/39          |    |    |
| 17/40          |    |    |
| 21/39          |    |    |
| 21/40          |    | X  |
| 23/45          |    |    |

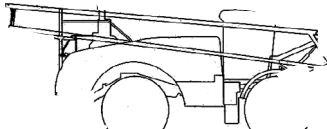
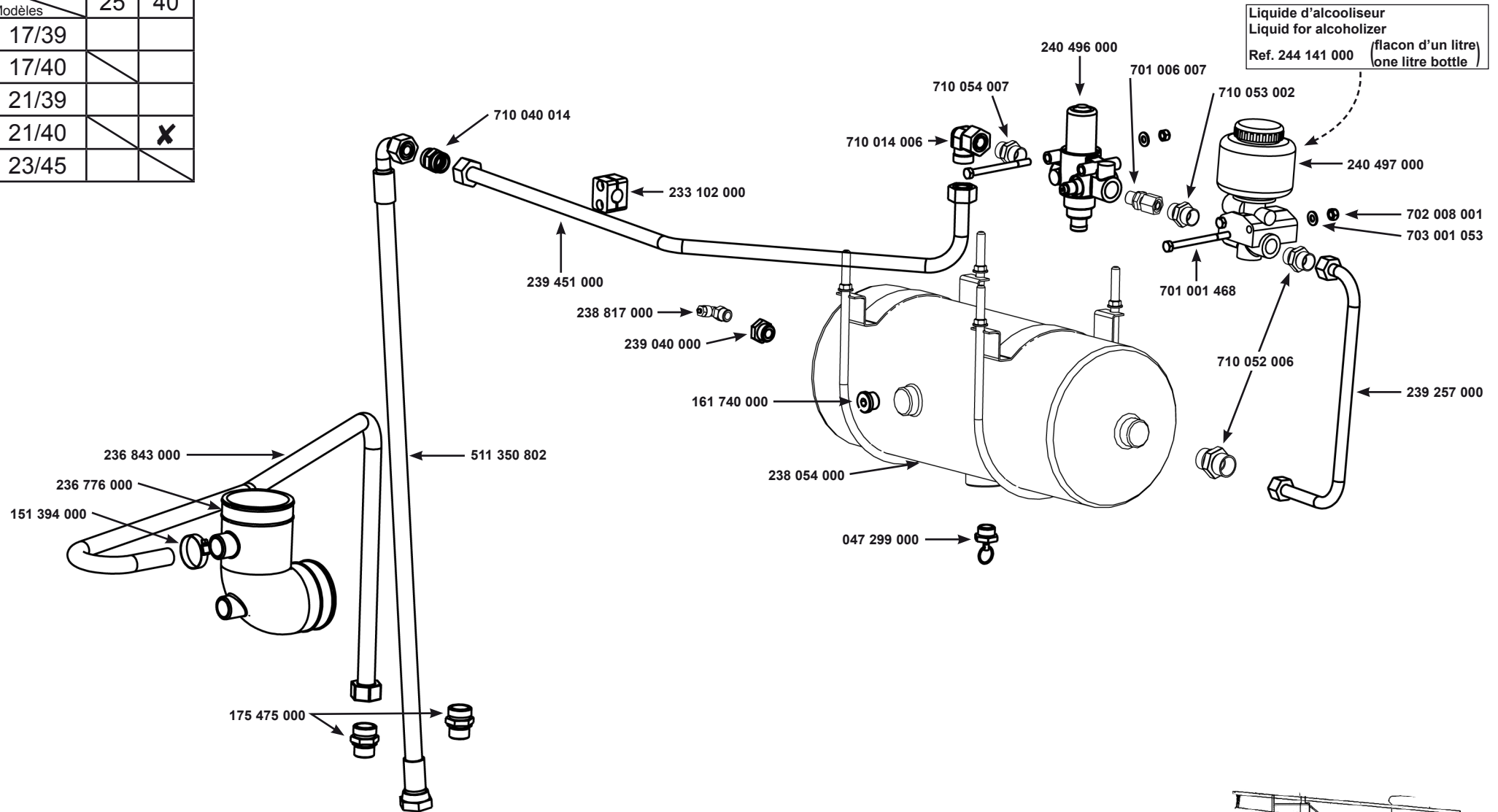



| Modèles \ Km/h | 25 | 40 |
|----------------|----|----|
| 17/39          | X  | X  |
| 17/40          |    | X  |
| 21/39          | X  | X  |
| 21/40          |    | X  |
| 23/45          | X  |    |

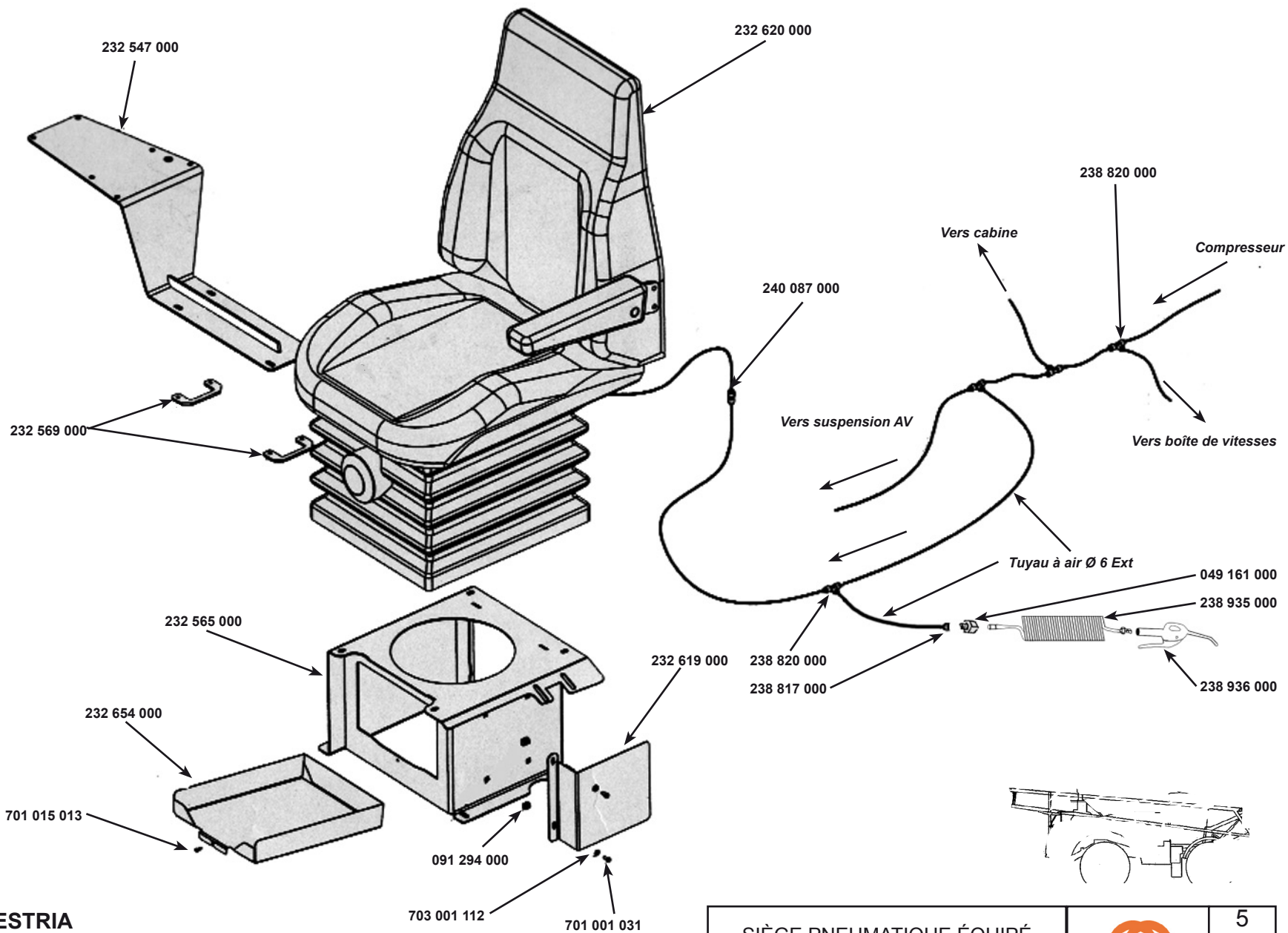

**CATALOGUE MAESTRIA**  
**RAMPE AV 2004**  
 Ajout mars 2009/March 2009 Add

|                                            |                                                                                       |                      |
|--------------------------------------------|---------------------------------------------------------------------------------------|----------------------|
| SIÈGE PNEUMATIQUE ÉQUIPÉ<br>PNEUMATIC SEAT |  | 5<br>C01<br>25/02/09 |
|--------------------------------------------|---------------------------------------------------------------------------------------|----------------------|



| Modèles | Km/h | 25 | 40 |
|---------|------|----|----|
| 17/39   |      | X  | X  |
| 17/40   |      |    | X  |
| 21/39   |      | X  | X  |
| 21/40   |      |    | X  |
| 23/45   |      | X  |    |

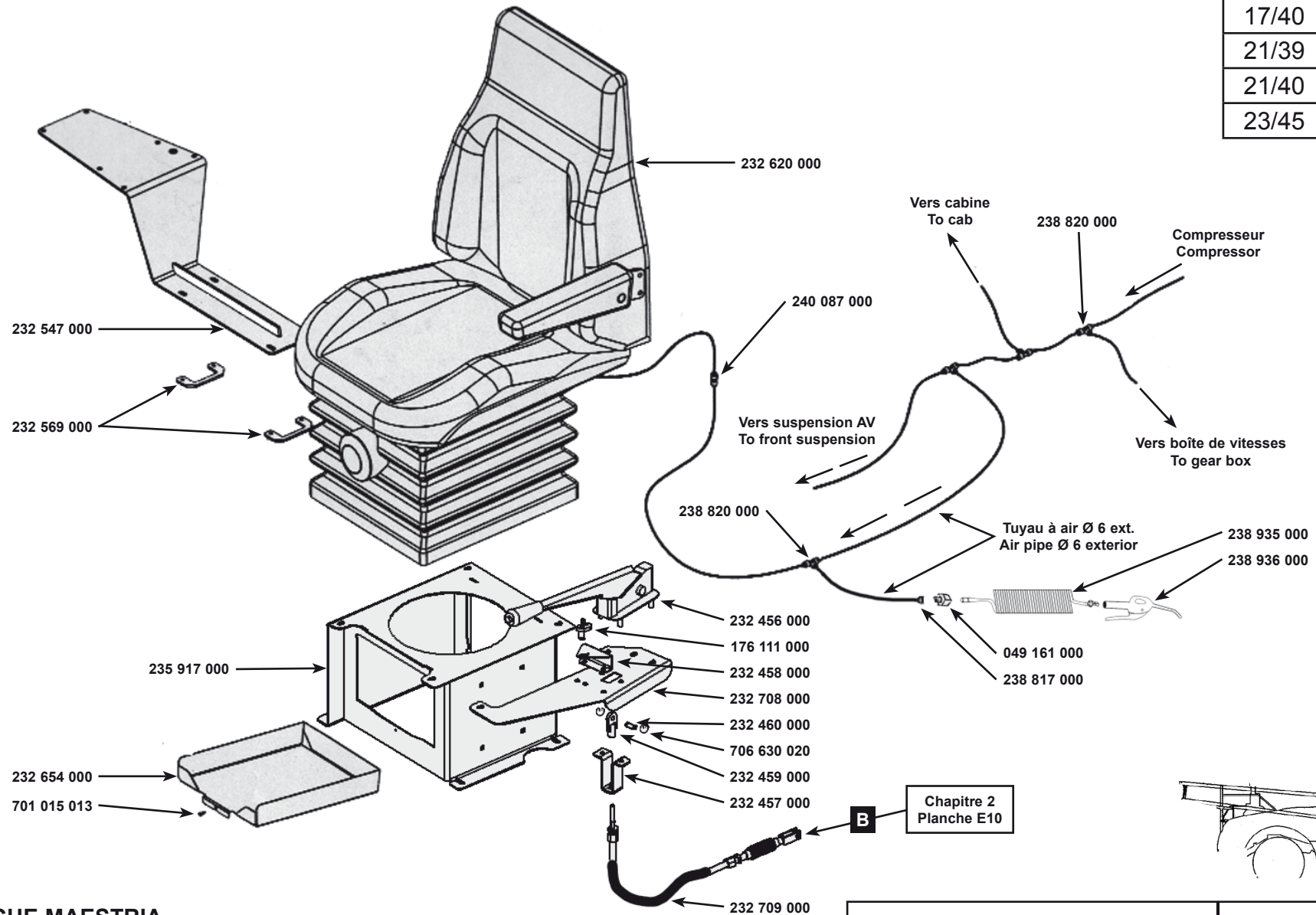

**CATALOGUE MAESTRIA**  
**RAMPE AV 2004**  
 Ajout mars 2009/March 2008 Add

|                                                         |  |                      |
|---------------------------------------------------------|--|----------------------|
| SIÈGE PNEUMATIQUE STABILIS®<br>STABILIS® PNEUMATIC SEAT |  | 5<br>C02<br>25/02/09 |
|---------------------------------------------------------|--|----------------------|