

Xénon	Boite 25km/h 1 moteur / 25km/h Gearbox 1 engine	21.11.2012
Matrot	230710000	Chap. 02
		P. 1

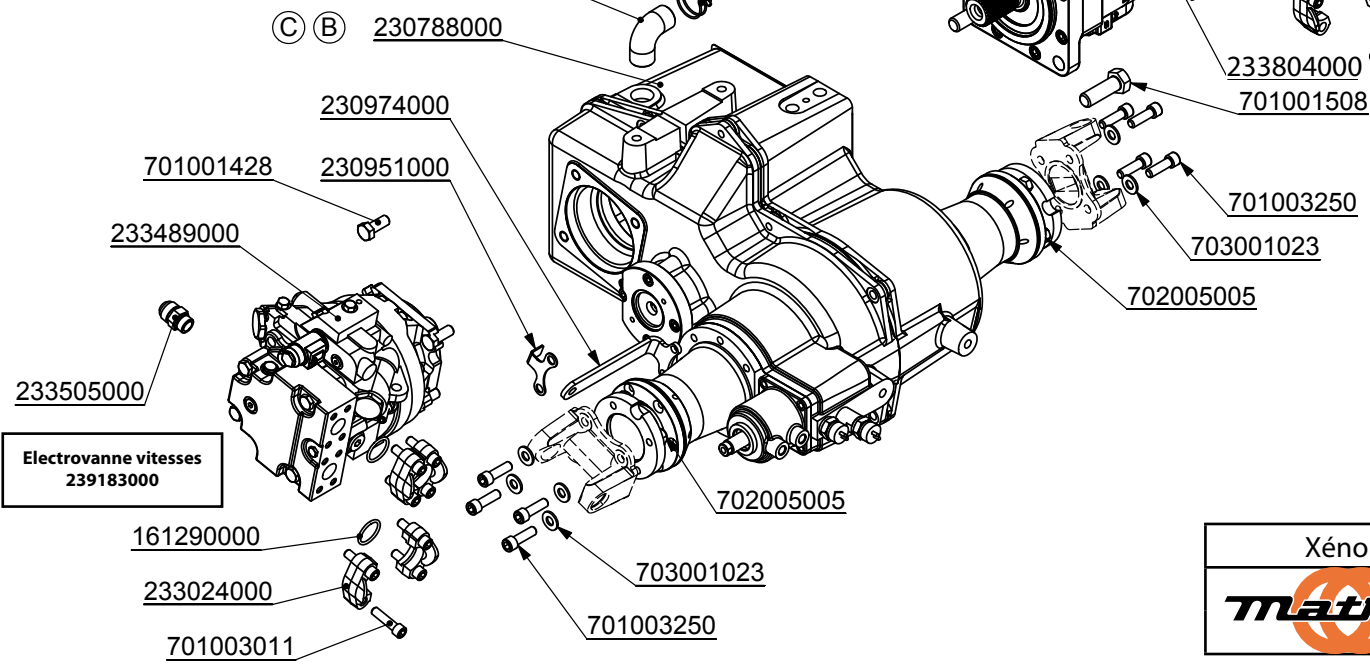

Xénon	Boîte 25km/h 2 moteurs / 25km/h Gearbox 2 engines	21.11.2012
Mathot	230711000	Chap. 02
		P. 2

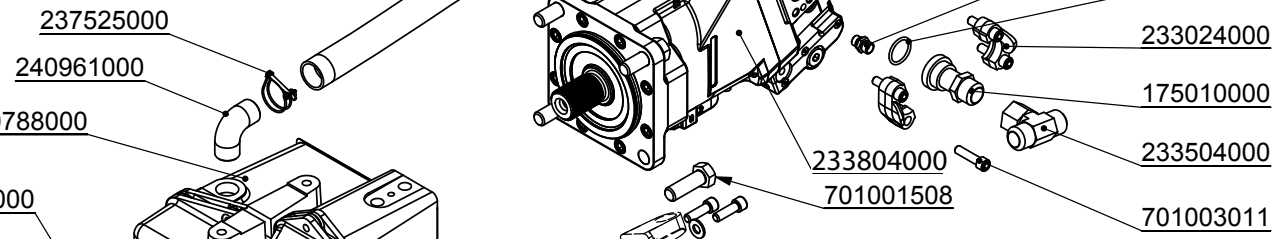
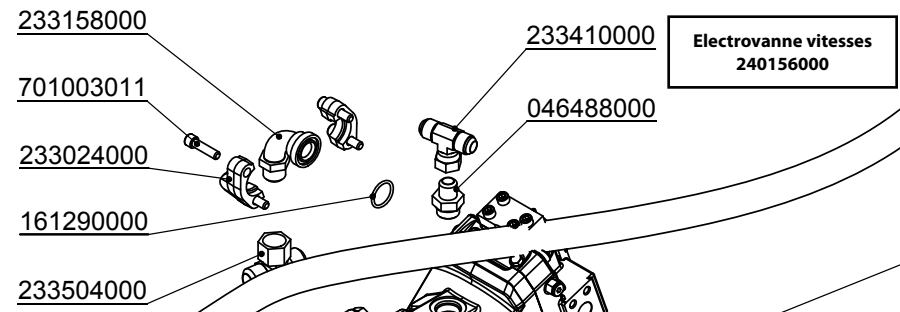
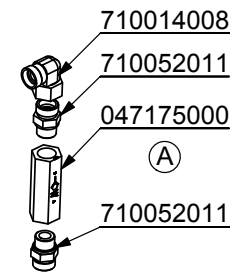
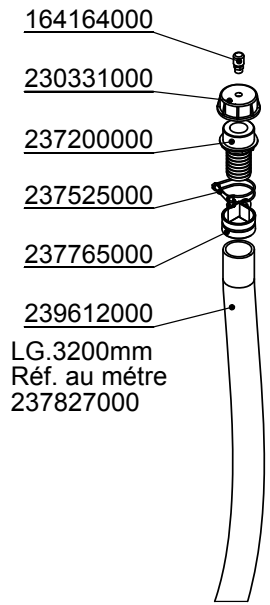
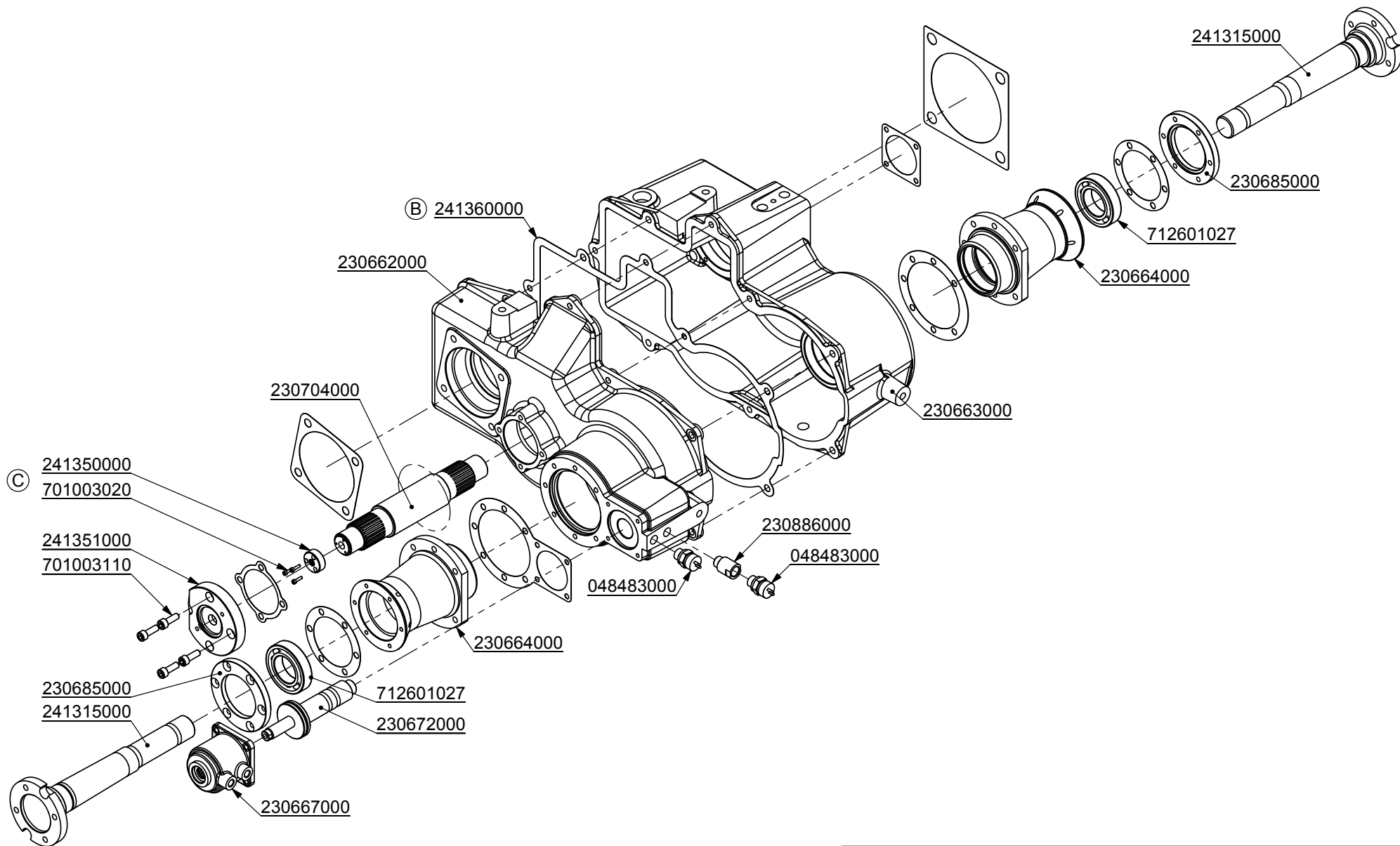

Xénon	Boîte 25km/h 2 moteurs / 25km/h Gearbox 2 engines	21.11.2012
Mathot		Chap. 02
	230788000	P. 3

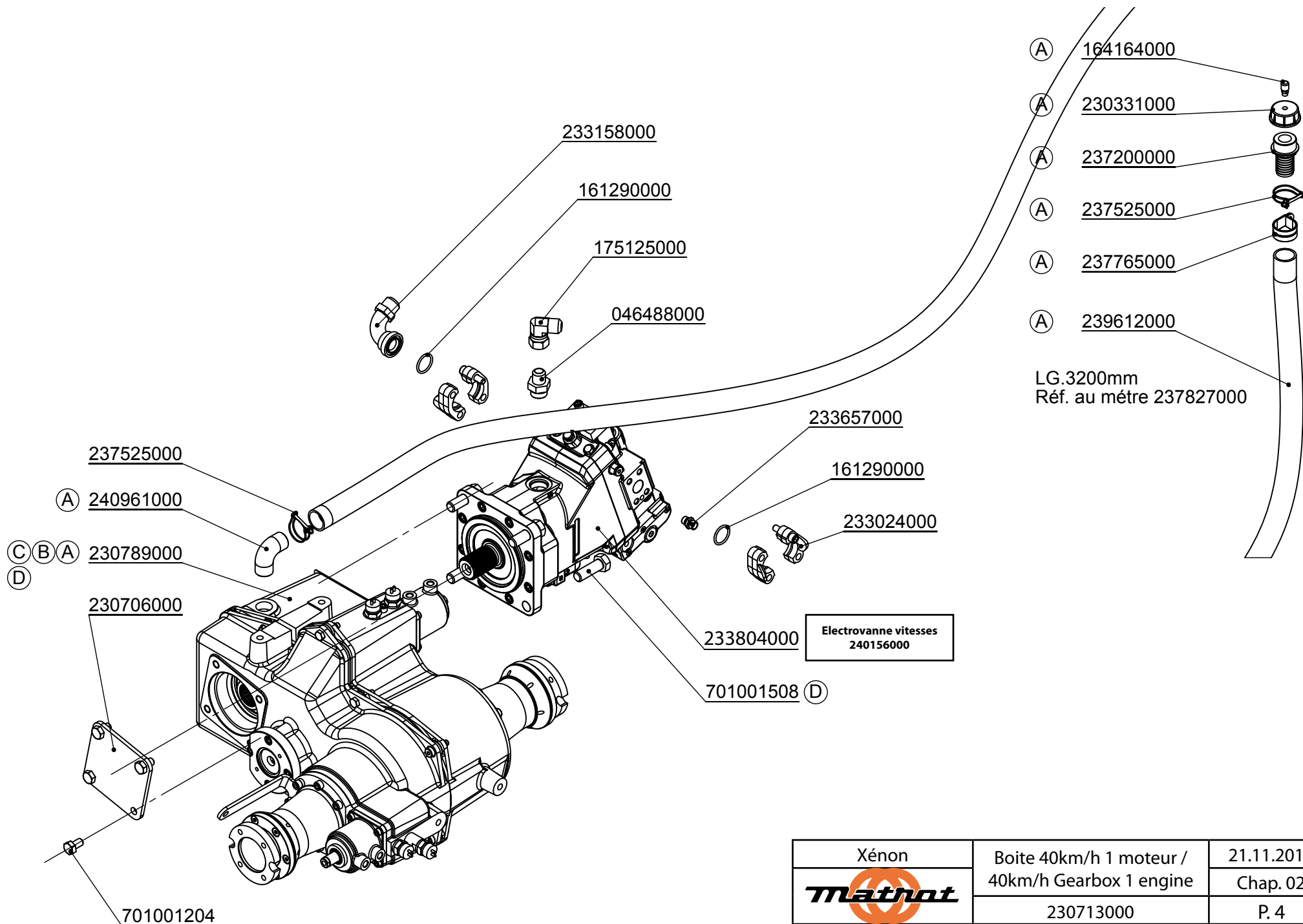

Xénon 	Boite 40km/h 1 moteur /	21.11.2012
	40km/h Gearbox 1 engine	Chap. 02
	230713000	P. 4

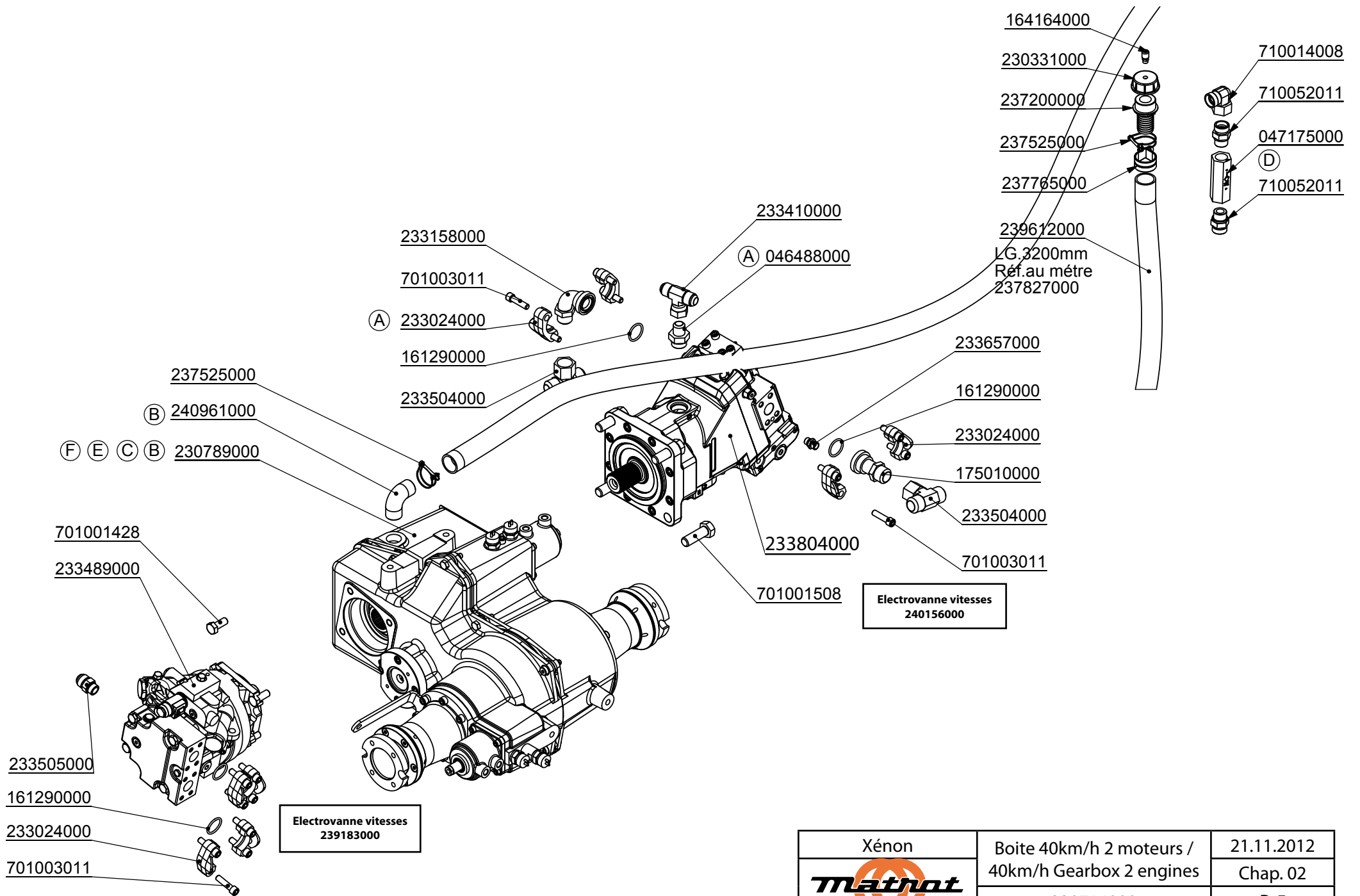

Xénon	Boîte 40km/h 2 moteurs / 40km/h Gearbox 2 engines	21.11.2012
Mathot	230714000	Chap. 02
		P. 5

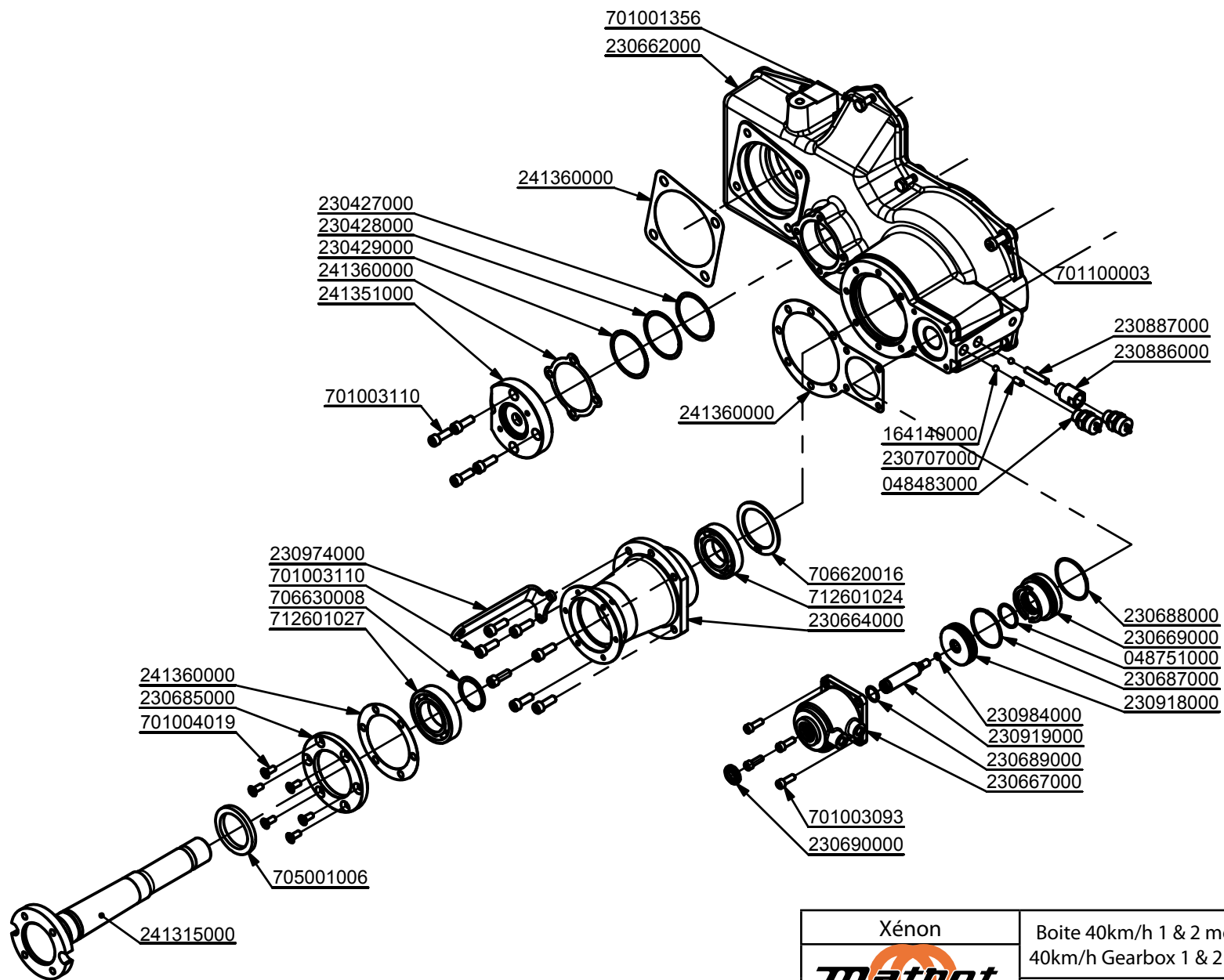

Xénon	Boite 40km/h 1 & 2 moteurs / 40km/h Gearbox 1 & 2 engines	21.11.2012
Mathot		Chap. 02
	230789000	P. 6

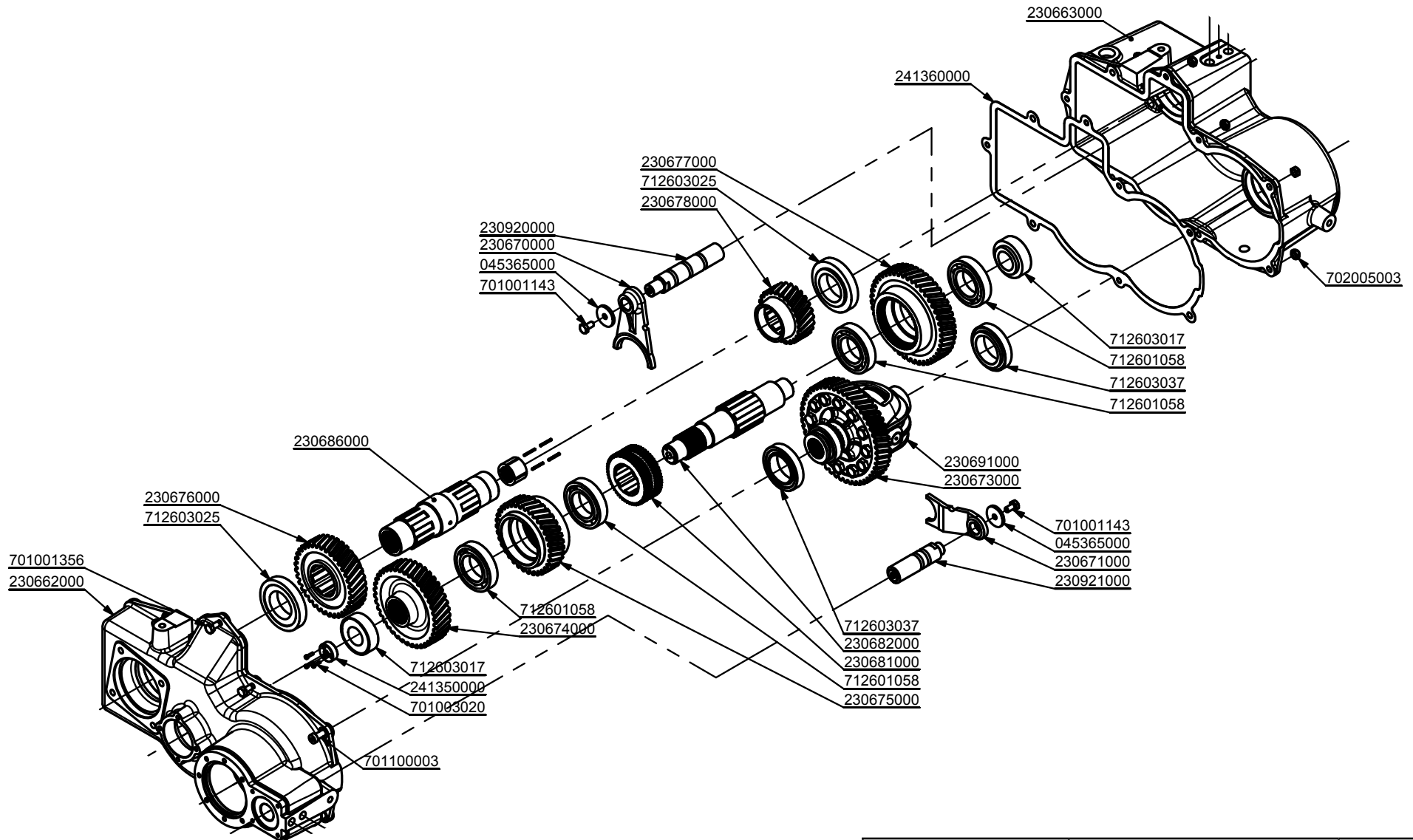

Xénon	Boite 40km/h 1 & 2 moteurs / 40km/h Gearbox 1 & 2 engines	21.11.2012
Mathot		Chap. 02
	230789000	P. 7

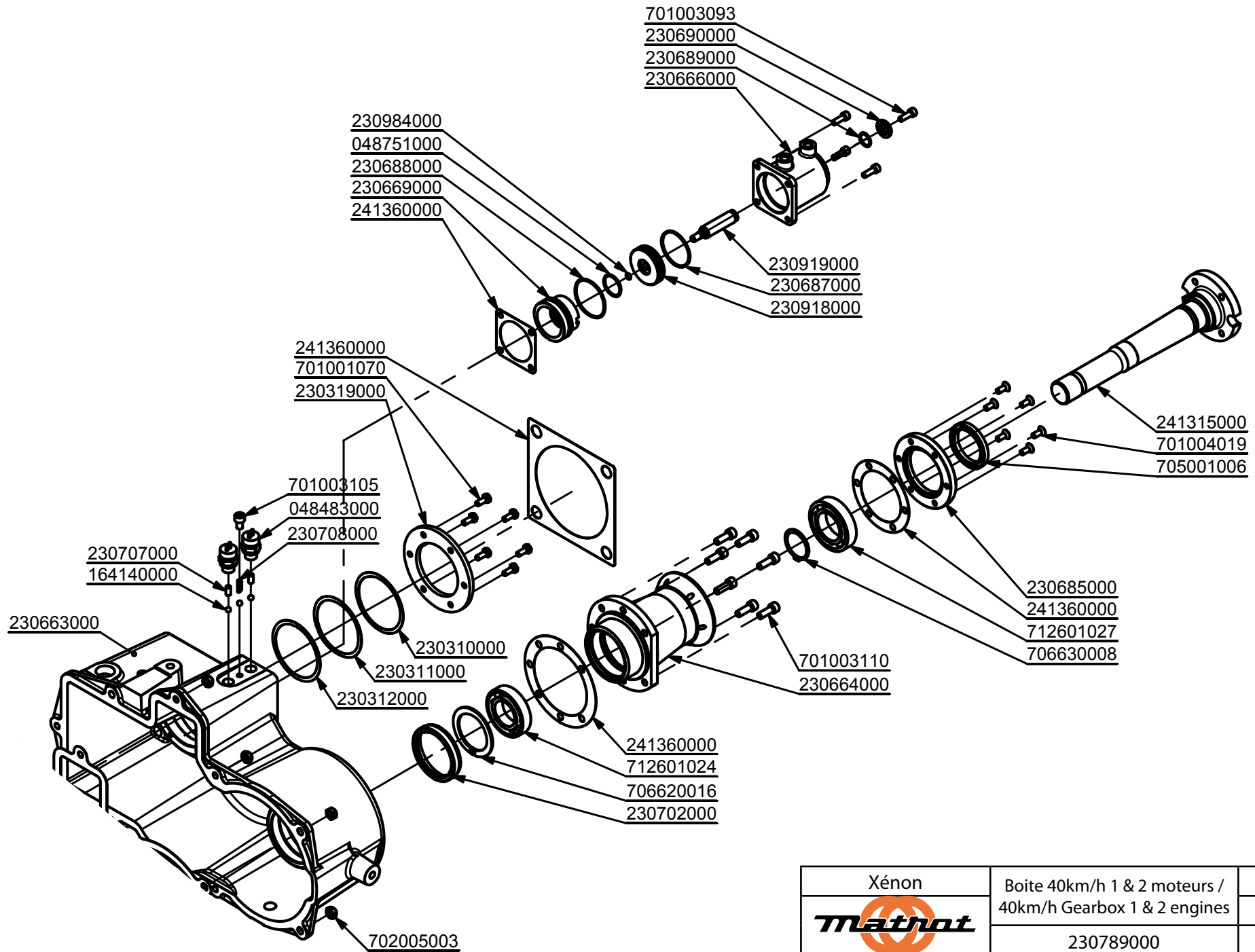

Xénon	Boite 40km/h 1 & 2 moteurs / 40km/h Gearbox 1 & 2 engines	21.11.2012
Mathot		Chap. 02
	230789000	P. 8

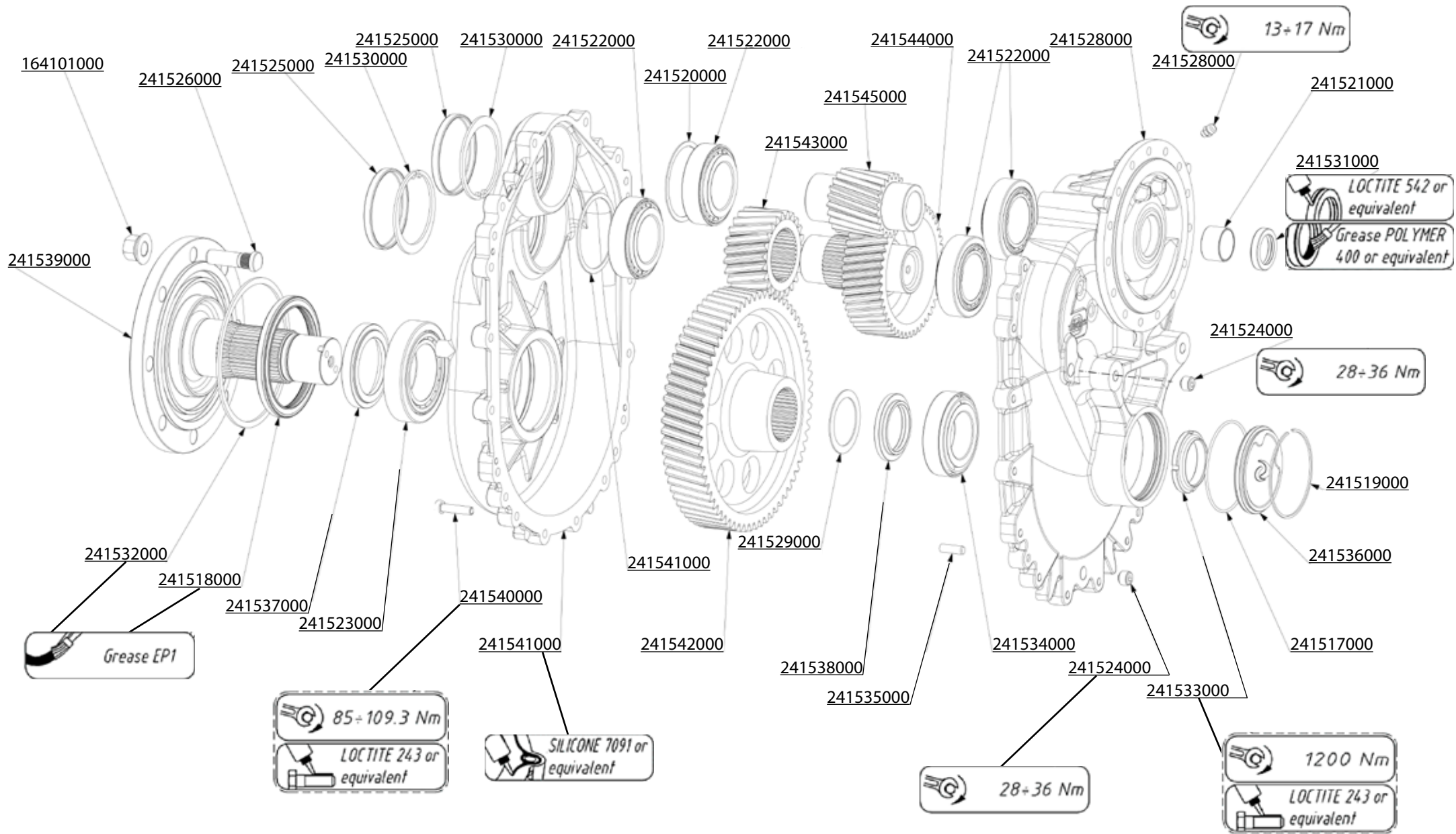

Xénon	Réducteur	29.10.2014
		Chap. 02
	241272000	P. 9

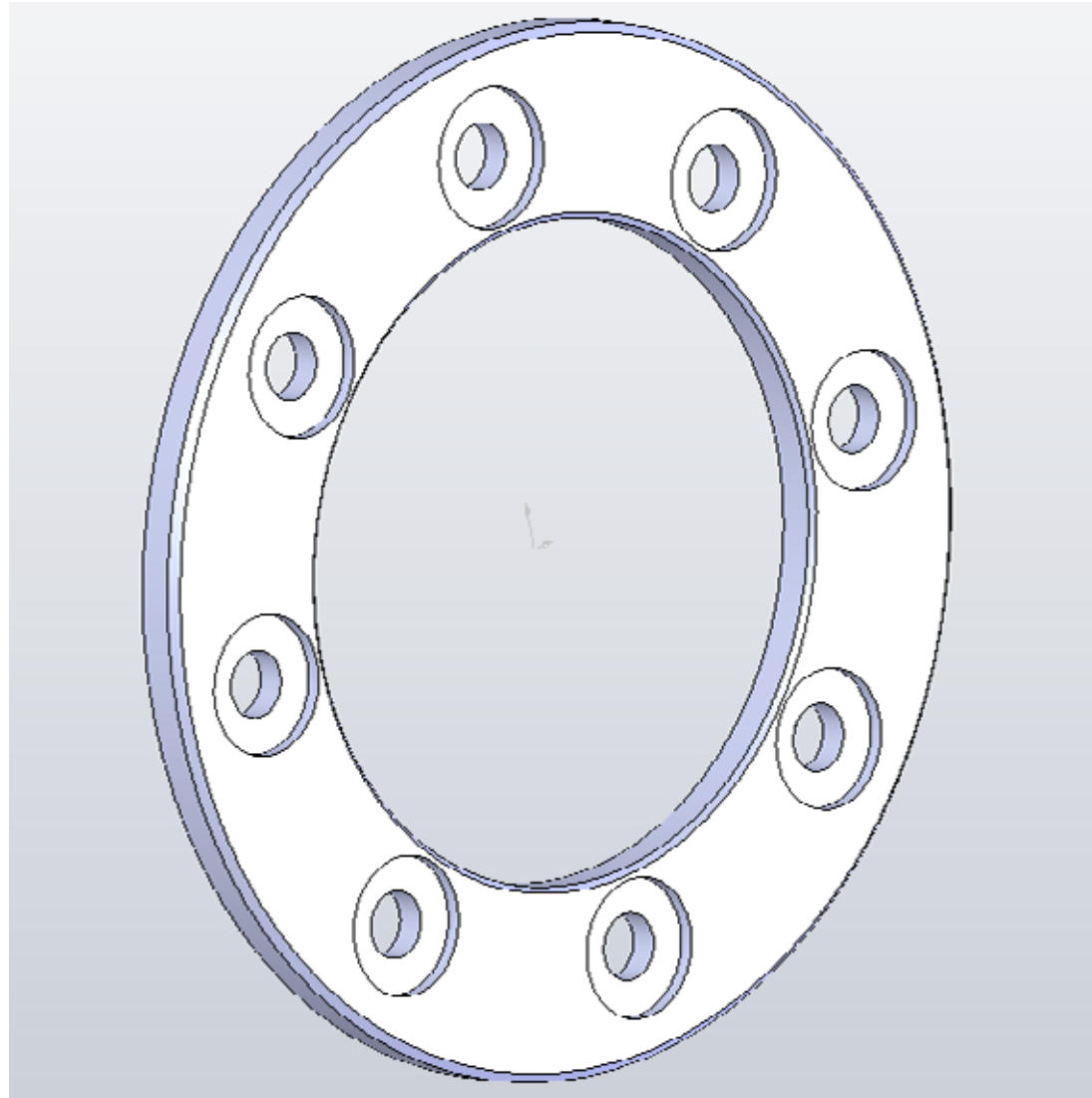

Xénon	Renfort de voile	29.10.2014
		Chap. 02
	241558000	P. 10

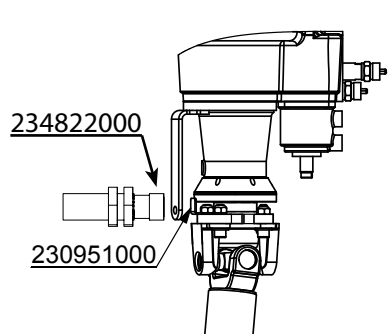

Capteur vitesse / Speed Sensor
234822000

Connecteur pour capteur de vitesse
176695000

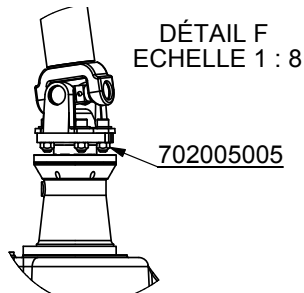

DÉTAIL F
ECHELLE 1 : 8

MONTAGE ECROU DEFORME
SUR ARBRE DE BOITE

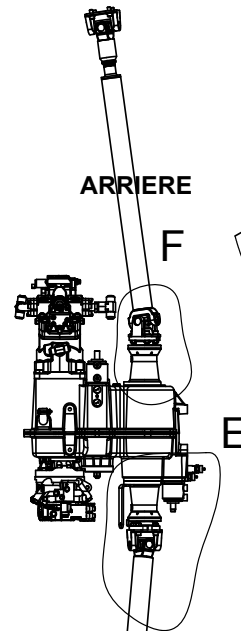

ARRIERE

F

E

AVANT

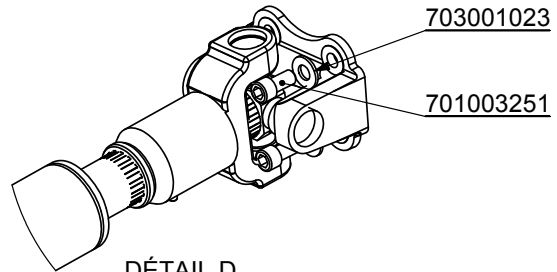

DÉTAIL D
ECHELLE 1 : 4

ARRIERE

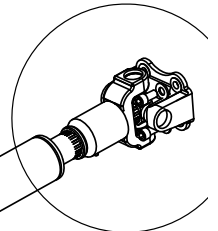

D

241316000

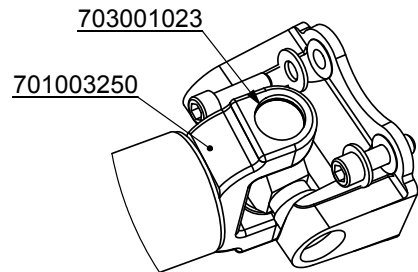

DÉTAIL A
ECHELLE 1 : 3

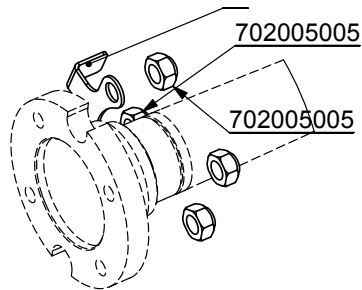

702005005

702005005

AVANT

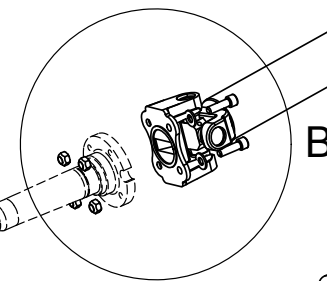

B

701003250 8 X
COUPLE DE
SERRAGE :
16 DaN.m

DÉTAIL B
ECHELLE 1 : 3

703001023

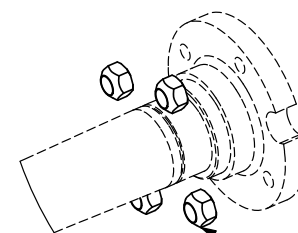

702005005

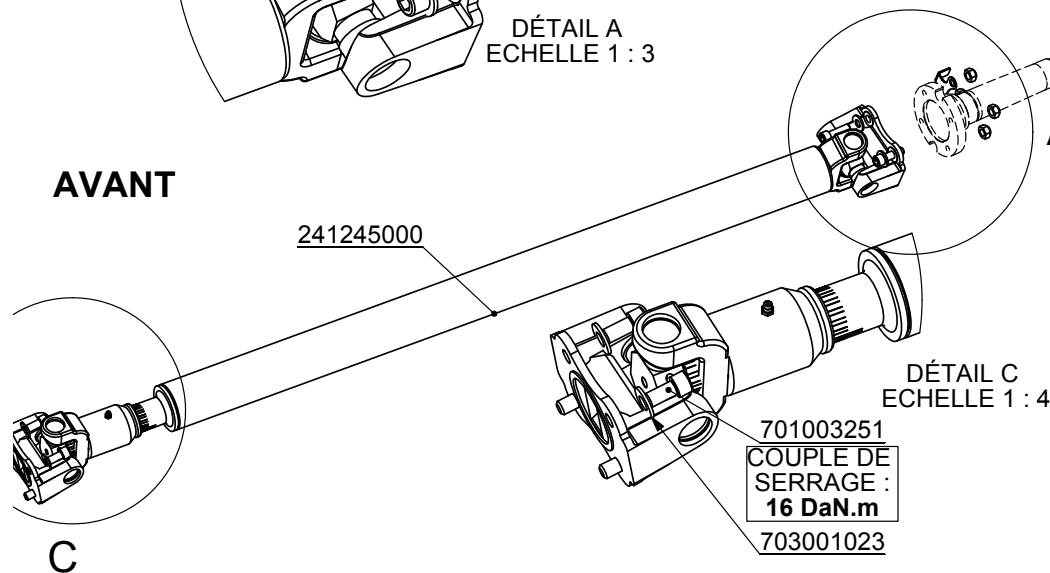

DÉTAIL C
ECHELLE 1 : 4

701003251
COUPLE DE
SERRAGE :
16 DaN.m
703001023

Xénon	Cardans / Universals Joints	30.09.2011
		Chap. 02
	241333000	P. 11

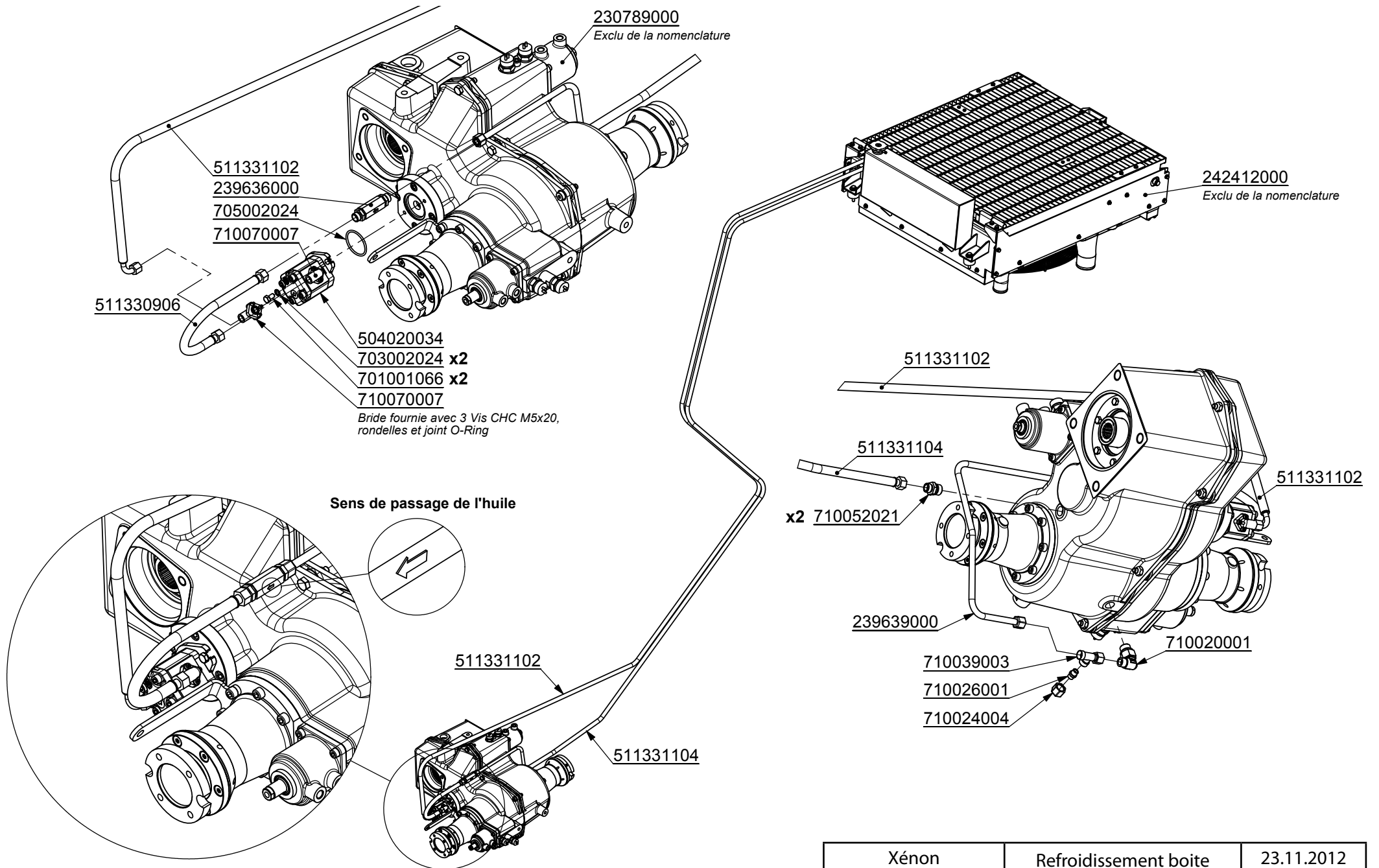

Xénon	Refroidissement boîte	23.11.2012
	Tier IIIA	Chap. 02
	239643000	P. 12

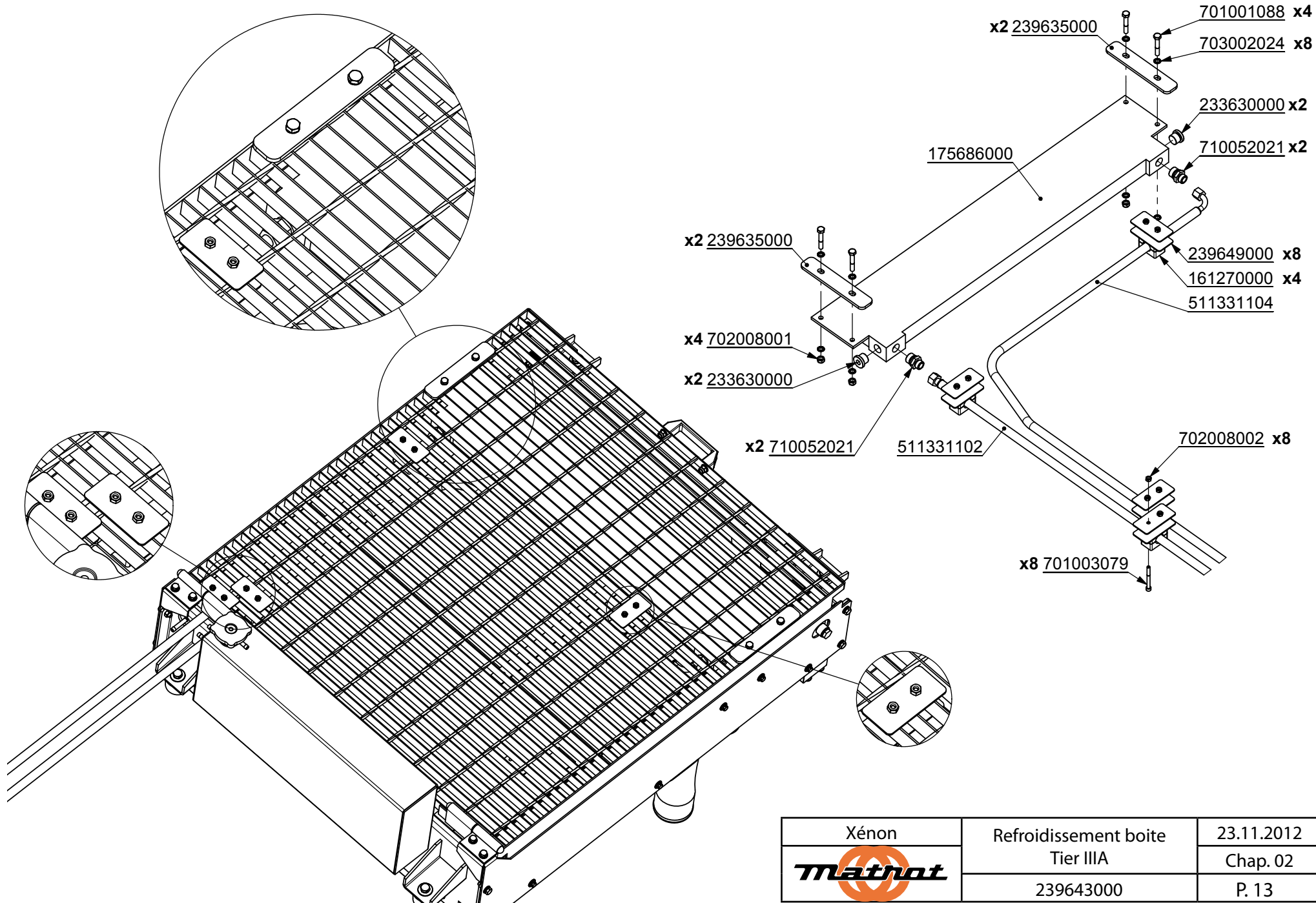

Xénon	Refroidissement boîte	23.11.2012
	Tier IIIA	Chap. 02
	239643000	P. 13

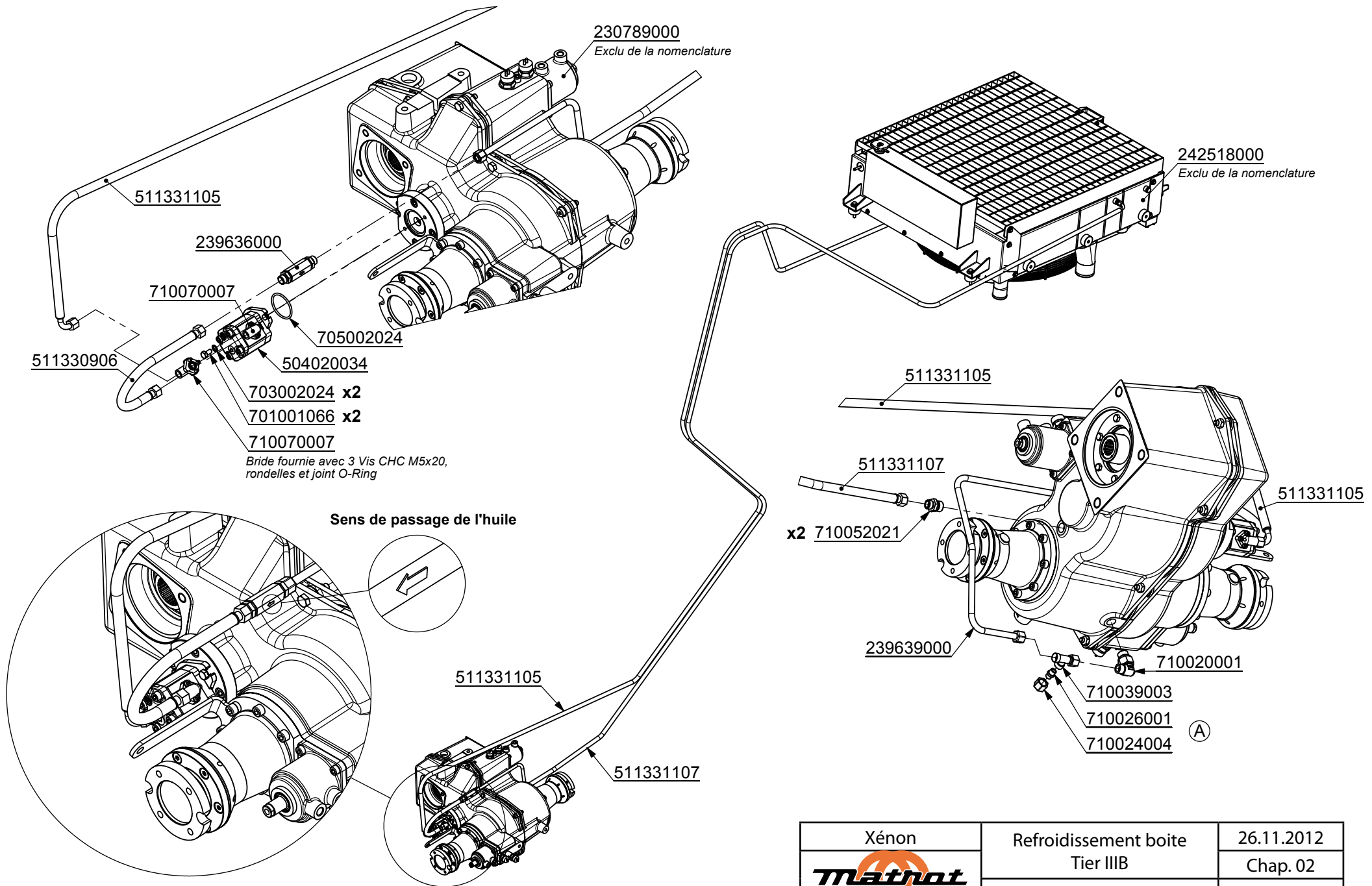

Xénon	Refroidissement boîte	26.11.2012
Mathot	Tier IIIB	Chap. 02
	239647000	P. 14

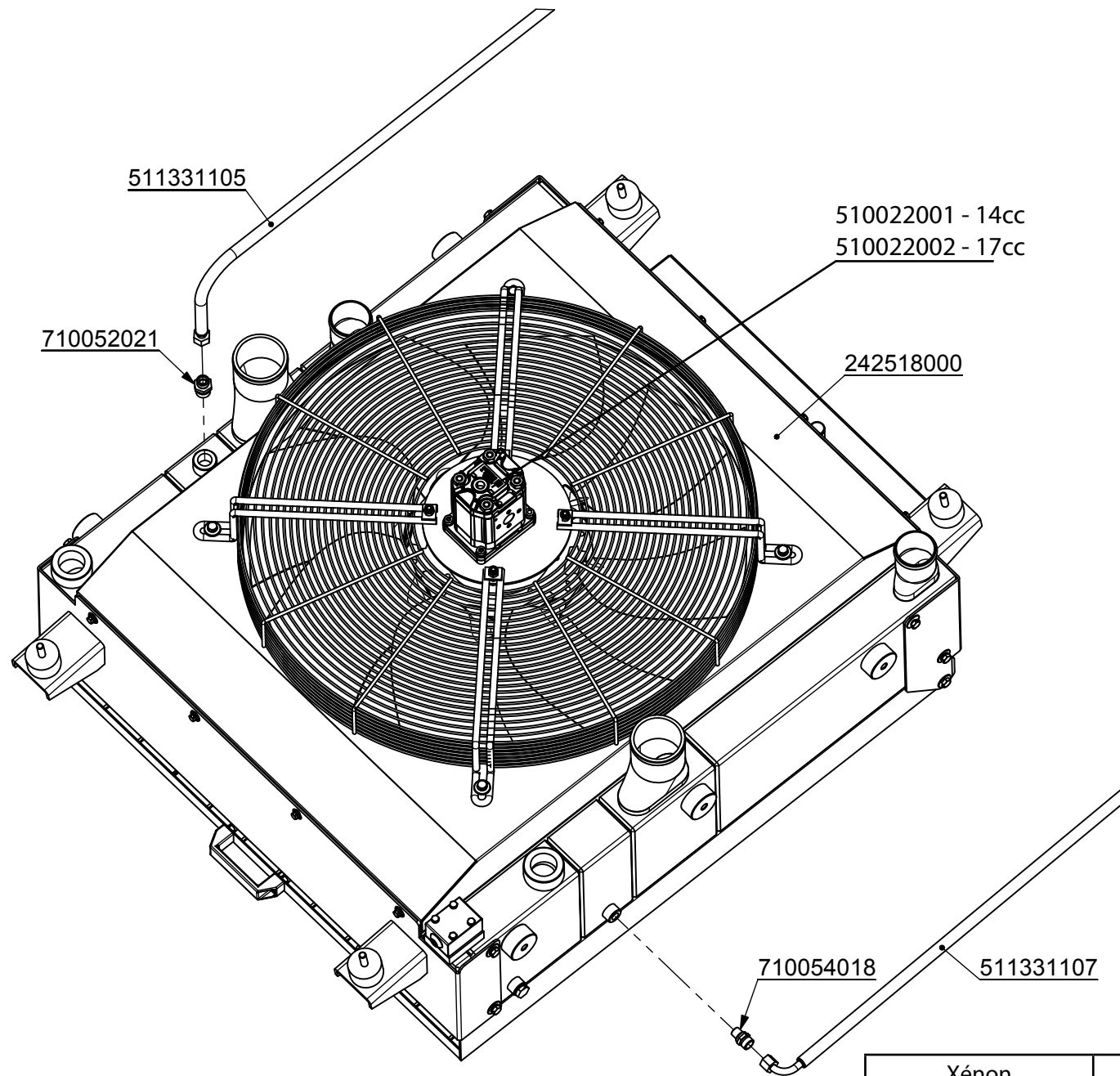

Xénon	Refroidissement boite	26.11.2012
	Tier IIIB	Chap. 02
	239647000	P. 15